

Rail-to-Rail I/O, 100mA Output Op Amp

Features

- Single-Supply Operation: 4V to 6V
- High Output Current: $\pm 100\text{mA}$
- Low Supply Current: $500\ \mu\text{A}$
- Wide Bandwidth: 3 MHz
- Slew Rate: $4\ \text{V}/\mu\text{s}$
- No Phase Reversal
- Unity Gain Stable
- Ultra-Small, 5-Pin SC70 Package

Applications

- Battery-Powered Instruments
- Portable Equipment
- Audio Signal Conditioning
- High-Side/Low-Side Current Sensors
- Multimedia Audio
- ASIC Input or Output Amplifier
- Headphone Driver

General Description

The G1211 is a rail-to-rail input and output single-supply amplifiers featuring 100mA output drive current. This high output current makes these amplifiers excellent for driving either resistive or capacitive loads. AC performance is very good with 3.0MHz bandwidth; $4.0\text{V}/\mu\text{s}$ slew rate and low distortion. All are guaranteed to operate from a +4 to +6 volt single supply.

The very low input bias currents enable the G1211 to be used for integrators and diode amplification and other applications requiring low input bias current. The 100mA high output current and supply current is only $850\ \mu\text{A}$ per amplifier at 5 volts, allowing low current applications to control high current loads.

Applications include audio amplification for computers, sound ports, sound cards and set-top boxes. The G1211 is very stable and capable of driving heavy capacitive loads. The ability to swing rail-to-rail at the inputs and outputs enables designers to buffer CMOS ADC/DACs, ASICs or other wide output swing devices in single-supply systems.

Ordering Information

PART	TEMP. RANGE	PIN-PACKAGE
G1211	0°C to 70°C	SC70-5L

Pin Configuration

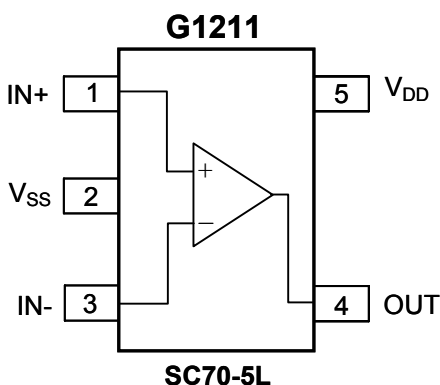

Typical Application Circuit

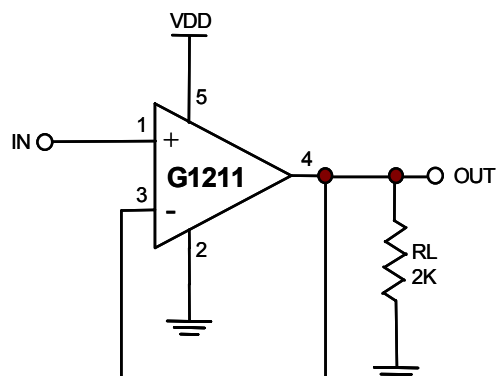

Absolute Maximum Ratings (Note1)

SYMBOL	PARAMETER	CONDITIONS	MIN.	MAX.	UNIT
V _{DD}	Supply voltage		0	7.0	V
T _{stg}	Storage temperature		-65	+150	°C
T _{amb}	Operating ambient temperature		0	+70	°C

Notes:

1. Absolute Maximum Ratings are limits beyond which damage to the device may occur.

Thermal Characteristics

SYMBOL	PARAMETER	VALUE	UNIT
R _{th j-a}	Thermal resistance from junction to ambient in free air SC70-5L	400	°C/W

Electrical Characteristics

V_{DD} = 5V; V_{SS} = 0V; T_{amb} = 25°C; f_i = 1kHz; R_L = 2kΩ; unless otherwise specified.

SYMBOL	PARAMETER	CONDITIONS	MIN.	TYP.	MAX.	UNIT
Supplies						
V _{DD}	Supply voltage		4.0	5.0	6.0	V
	Single		4.0	5.0	6.0	V
	Dual		2	2.5	3.0	V
V _{SS}	Negative supply voltage (dual)		-2.0	-2.5	-3.0	V
I _{DD}	Supply current	no load	-	0.85	1.2	mA
P _{tot}	Total power dissipation	no load	-	4.25	6.0	mW
DC Characteristics						
V _{I(OS)}	Input offset voltage			±1.5	±10	mV
V _{CM}	Common mode voltage		0	-	5.0	V
I _B	Input Bias Current			±0.05		nA
I _{OS}	Input Bias Current Offset			±0.05		nA
R _{IN}	Input Resistance			1000	-	MΩ
A _v	Large-Signal Voltage Gain			80	-	dB
I _O	Maximum output current	THD<0.1%, R _L = 16Ω	-	100	-	mA
R _O	Output resistance	Open-loop, R _L = 20Ω	-	5.5	-	Ω
V _O	Output voltage swing	R _L = 32Ω	1.0	-	4.0	V
		R _L = 2kΩ	0.1	-	4.9	V
PSRR	Power supply rejection ratio	f _i = 1kHz; V _{ripple(peak)} = 1V		60	-	dB
CMRR	Common-Mode Rejection Ratio			56		dB
AC Characteristics						
THD	Total harmonic distortion	Note 2	-	< 0.1	-	%
		R _L = 2kΩ, Note 2				
GBWP	Gain-Bandwidth Product	Open-loop; No Load	-	3.0	-	MHz
SR	Slew-Rate	Measured from 30% to 70% of 5Vp-p step		4		V/μs
PM	Phase Margin		-	60	-	deg
P _O	Maximum output power	Note 1; R _L = 32Ω	-	135	-	mW
B	Power bandwidth	Unity gain; R _L = 32Ω	-	25	-	KHz

Notes:

- Values are proportional to V_{DD}; THD < 0.1%
- V_{DD} = 5.0V; V_{O(P-P)} = 4.0V (at 0 dB)

Output Swing Range Voltage Figure

Test Condition : $T_A = 25^\circ\text{C}$, $A_V = -1$

$V_+ = 2.5\text{V}$, $V_- = -2.5\text{V}$, $R_L = 2\text{k}\Omega$

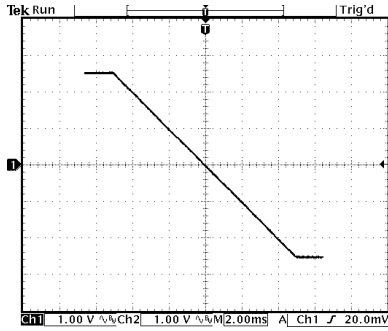

$V_+ = 2.5\text{V}$, $V_- = -2.5\text{V}$, $R_L = 250\Omega$

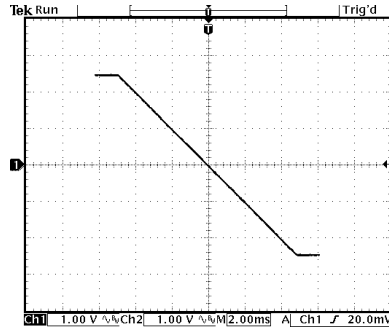

$V_+ = 2.5\text{V}$, $V_- = -2.5\text{V}$, $R_L = 32\Omega$

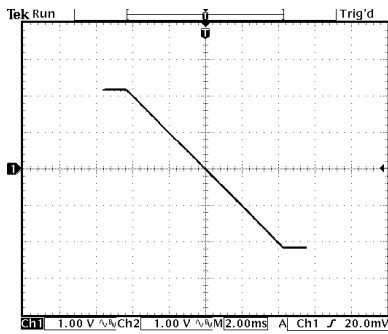

$V_+ = 2.5\text{V}$, $V_- = -2.5\text{V}$, $R_L = 16\Omega$

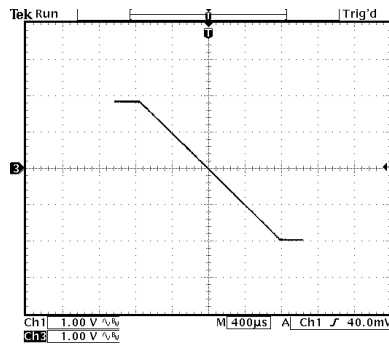

Input Common Mode Voltage Range Figure

Test Condition : $T_A = 25^\circ\text{C}$, $A_V = 1$

$V_+ = 5\text{V}$, $V_- = 0\text{V}$, $R_L = 2\text{K}\Omega$

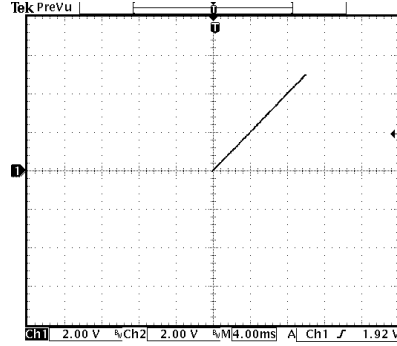
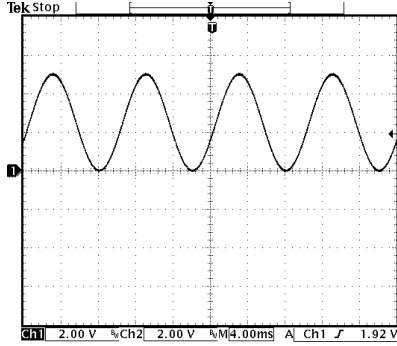

$V_+ = 5\text{V}$, $V_- = 0\text{V}$, $R_L = 250\Omega$

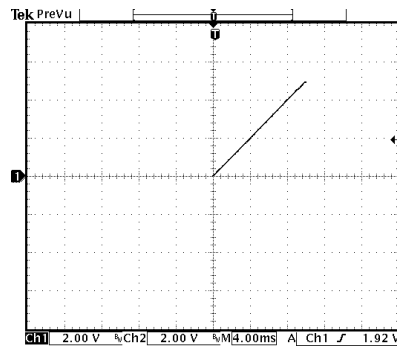
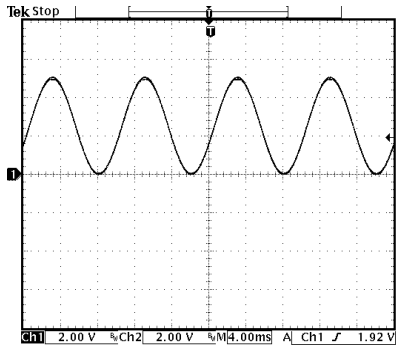

Large Signal Transient Response Figure

Test Condition : TA=25°C, AV=1 , RL = 2kΩ

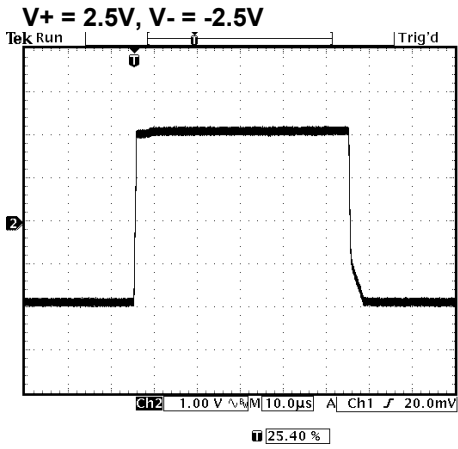

Small Signal Transient Response Figure

Test Condition : TA=25°C, AV=1 , RL = 32Ω

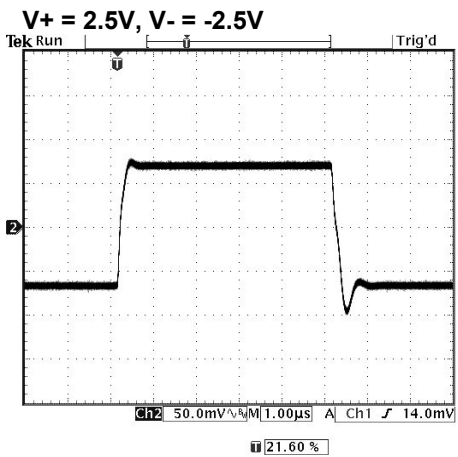

Test Condition: Vs = ±2.5V, TA = 25°C

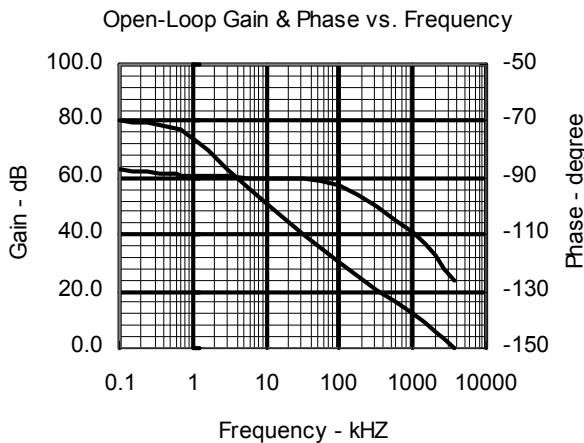

Test Condition: Vs = ±2.5V, TA = 25°C

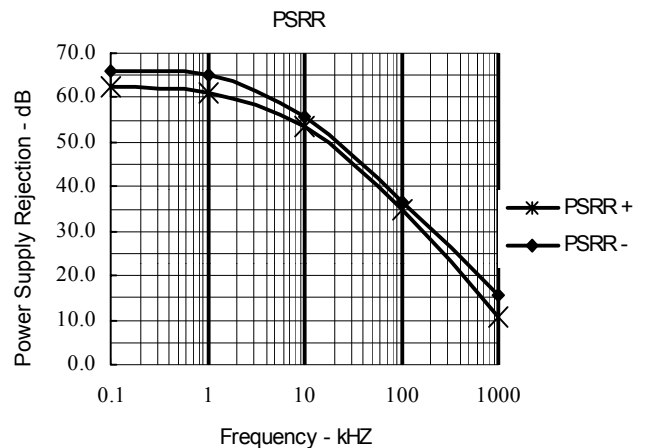

Package Information

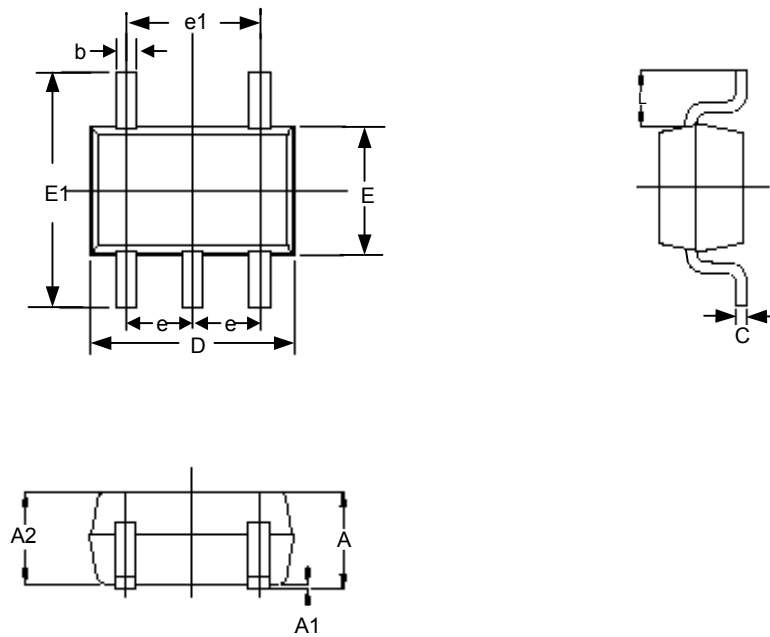

Note:

1. All dimensions are in millimeters
2. Dimensions are inclusive of plating of plating
3. Dimensions are exclusive of mold flash & metal burr
4. All specifications comply to EIAJ SC70
5. Coplanarity 4 Mils. Max.

SYMBOL	DIMENSION IN MM		DIMENSION IN INCH	
	MIN.	MAX.	MIN.	MAX.
A	0.90	1.20	0.035	0.047
A1	0.05	0.15	0.002	0.006
A2	0.85	1.05	0.033	0.041
b	0.20	0.40	0.008	0.016
C	0.10	0.15	0.004	0.006
D	1.90	2.10	0.075	0.083
E	1.15	1.35	0.045	0.053
E1	2.00	2.20	0.0787	0.0866
e	0.65 BSC		0.0256 BSC	
e1	1.30 BSC		0.0512 BSC	
L	0.425 REF		0.0167 REF	

Package Orientation

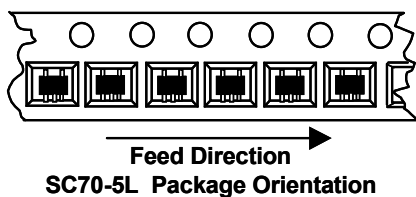

GMT Inc. does not assume any responsibility for use of any circuitry described, no circuit patent licenses are implied and GMT Inc. reserves the right at any time without notice to change said circuitry and specifications.