

## FEATURES

- highly configurable, versatile DSP platform
- high fidelity multi-channel AGC signal processing
- 95dB input dynamic range with HRX™ Headroom Extension
- fully programmable via serial data interface
- high performance data converters - dual, over-sampled A/Ds; over-sampled D/A with efficient switched-mode output power amp
- SOUNDDESIGN™ high-fidelity audio quality
- drives zero-bias 2-terminal receivers
- multiple communication rates up to 85.3kb/s
- thinSTAX™ packaging - CIC size
- multi-memory
- internal/external volume control
- volume control taper determined by external VC
- tri-state memory select operation
- audible memory change indicator

## thinSTAX™ PACKAGING

Hybrid typical dimensions:

0.227 x 0.125 x 0.060 in  
(5.76 x 3.18 x 1.52 mm)

## DESCRIPTION

The GB3215 (GB3225) hybrid is a programmable DSP system based on a multi-channel compression circuit. It can be used as a platform for a wide range of hearing aid applications. Its extensive programmability and compact size make it ideal for sophisticated CIC applications. The reflowable thinSTAX™ packaging enables easy integration into BTE applications. This very versatile DSP hybrid is capable of multiple configurations and has a wide range of functions.

The GB3215 hybrid contains the GC5051 controller chip and the GB3225 hybrid contains the GC5057 controller chip. The only difference between the GC5051 and the GC5057 is in their Power On Reset (POR) behaviour.

For a detailed description of the POR behaviour of the GC5051 and GC5057 controller chips, please refer to [PARAGON™ DIGITAL Reference Guide](#), Document #20143.

The GB3215 and the GB3225 hybrid code programmed into the GC5051 and the GC5057 controller chips is "9".

This data sheet is a part of a set of documents available for this product. Please refer to "Getting Started with PARAGON™ DIGITAL" information note for a list of other documents.

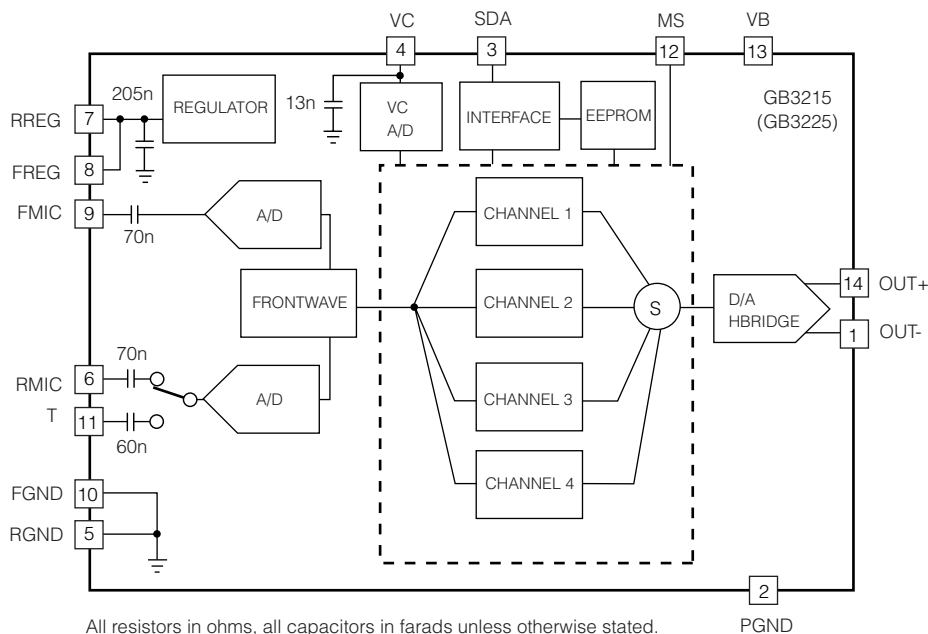

All resistors in ohms, all capacitors in farads unless otherwise stated.

## BLOCK DIAGRAM

### ABSOLUTE MAXIMUM RATING

Operating Temperature Range:	-10°C to 40°C
Storage Temperature Range:	-20°C to 70°C
Absolute Maximum Power Dissipation:	25mW
Maximum Operating Supply Voltage:	1.5VDC
Absolute Maximum Supply Voltage:	2VDC

### PAD CONNECTION

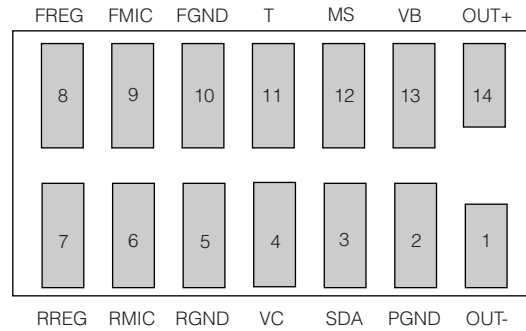

**CAUTION**  
ELECTROSTATIC  
SENSITIVE DEVICES

DO NOT OPEN PACKAGES OR HANDLE  
EXCEPT AT A STATIC-FREE WORKSTATION

**CAUTION**  
LEVEL 3 MOISTURE  
SENSITIVE DEVICES

DO NOT OPEN PACKAGES EXCEPT UNDER  
CONTROLLED CONDITIONS

### ELECTRICAL CHARACTERISTICS

Conditions: Supply Voltage  $V_B = 1.3V$ ; Temperature = 25°C

PARAMETER	SYMBOL	CONDITIONS	MIN	TYP	MAX	UNITS
Hybrid Current	$I_{AMP}$	See current consumption section	-	700	-	$\mu A$
Minimum Operating Supply Voltage	$V_{BOFF}$	Ramp down	0.94	1.0	1.05	V
Supply Voltage turn on threshold	$V_{BON}$	Ramp up	1.06	1.10	1.16	V
Supply Voltage Hysteresis			90	100	110	mV
Supply Voltage during Communication	$V_{BC}$	During Communication	1.19	1.35	1.5	V
Hybrid Current during Communication	$I_P$	Programming (<5 ms)	-	3.7	-	mA
EEPROM Burn Cycles		Note 2	100k	-		cycles
Low Frequency System Bandwidth			100	140	225	Hz
High Frequency System Bandwidth			15.2	16	16.8	kHz
Total Maximum System Gain	$A_V$	$V_{IN} = -95$ dBV @ 3kHz; squelch disabled See Note 1.	81	83	85	dB
Converter Gain	$A_{CONV}$	A/D + D/A gain.	27	29	31	dB
Total Harmonic Distortion	THD	$V_{IN} = -40$ dBV	-	0.05	1	%
THD at Maximum Input	THD <sub>M</sub>	$V_{IN} = -15$ dBV, HRX - ON	-	1.5	3	%
Clock Frequency	$f_{clk}$		1.945	2.048	2.151	MHz
<b>REGULATOR</b>						
Regulator Voltage	$V_{REG}$		0.90	0.95	1.00	V
Regulator Supply Rejection	PSRR <sub>REG</sub>		-	50	-	dB

## ELECTRICAL CHARACTERISTICS (CONTINUED)

Conditions: Supply Voltage  $V_B = 1.3V$ ; Temperature = 25°C

PARAMETER	SYMBOL	CONDITIONS	MIN	TYP	MAX	UNITS
<b>INPUT</b>						
Input Referred Noise	IRN	Bandwidth 100Hz - 8kHz	-	-108	-106	dBV
Input Impedance	$Z_{IN}$		11.2	16	22	k $\Omega$
Anti-alias Filter Rejection (input referred)		$f=f_{clk}-8kHz, V_{IN} = -40dBV$	-	80	-	dB
Maximum Input Level			-	-15	-	dBV
Input Dynamic Range		HRX - ON, Bandwidth 100Hz - 8kHz	-	95	-	dB
Audio Sample Rate			30.4	32	33.6	kHz
A/D Dynamic Range		Bandwidth 100Hz - 8kHz	-	86	-	dB
<b>OUTPUT</b>						
Maximum RMS Output Voltage		0dBFS $f = 1kHz$	-3	-1	1	dBV
D/A Dynamic Range		Bandwidth 100Hz - 8kHz	80	-	-	dB
Output Impedance	$Z_{OUT}$	Note 2	-	-	20	$\Omega$
<b>VOLUME CONTROL</b>						
Volume Control Resistance	$R_{VC}$		160	200	240	k $\Omega$
Volume Control Range	$\Delta A$		47.5	48	48.5	dB
<b>MS INPUT</b>						
Low State	Lo		0	-	$V_{REG}/3$	V
Open State	Z		$V_{REG}/3$	-	$2V_{REG}/3$	V
High State	Hi		$2V_{REG}/3$	-	$V_B$	V
<b>SDA INPUT</b>						
Logic 0 Voltage		Note 2	0	-	0.3	V
Logic 1 Voltage		Note 2	1	-	1.3	V
<b>SDA OUTPUT</b>						
Standby Pull Up Current			1.4	2	2.6	$\mu A$
Sync Pull Up Current			450	500	550	$\mu A$
Logic 0 Current (Pull Down)			225	250	275	$\mu A$
Logic 1 Current (Pull Up)			225	250	275	$\mu A$
Synchronization Time (Synchronization Pulse Width)	$T_{SYNC}$	Baud = 0	237	250	263	$\mu s$
		Baud = 1	118	125	132	$\mu s$
		Baud = 2	59	62.5	66	$\mu s$
		Baud = 3	29.76	31.25	32.81	$\mu s$
		Baud = 4	14.88	15.63	16.41	$\mu s$
		Baud = 5	7.44	7.81	8.20	$\mu s$
		Baud = 6	3.72	3.91	4.10	$\mu s$
		Baud = 7	1.86	1.95	2.05	$\mu s$

NOTE 1: Total System Gain consists of: *Wideband System Gain + High and Low Independent Channel Gains + Converter Gain*

Total System Gain is calibrated during Cal/Config process.

NOTE 2: Sample tested.

## SUPPORT SOFTWARE

All support software for the GB3215 / GB3225 is available from

Gennum Web Site

[www.gennum.com/hip/software/index.html](http://www.gennum.com/hip/software/index.html).

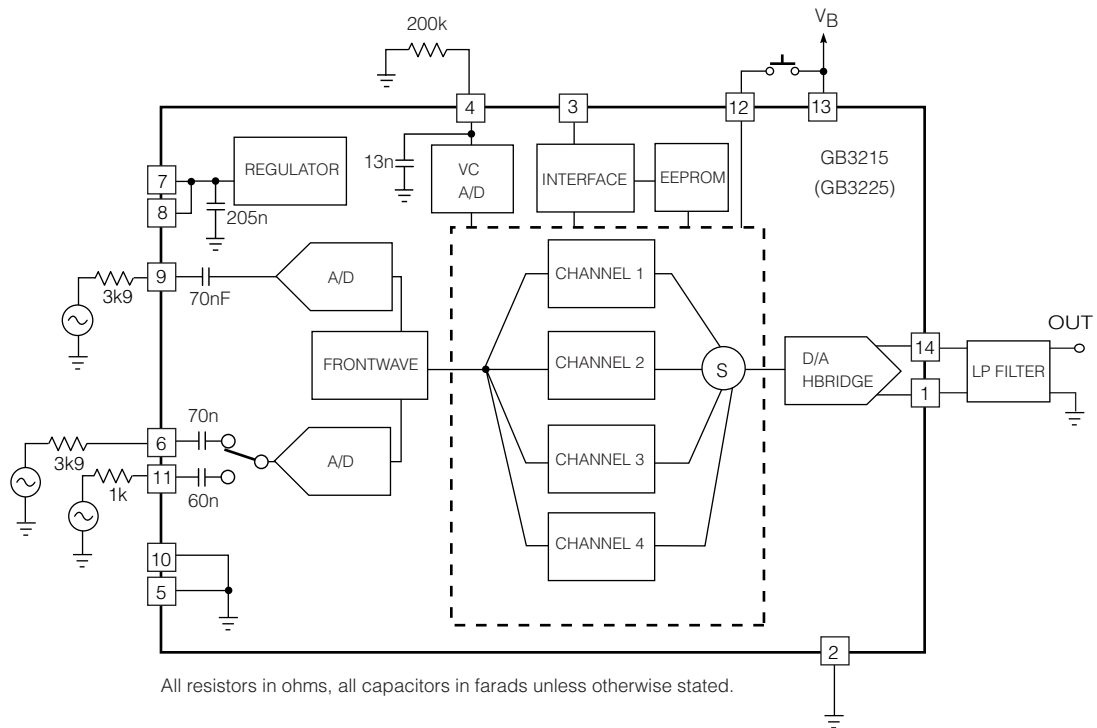

Figure 1: Test Circuit

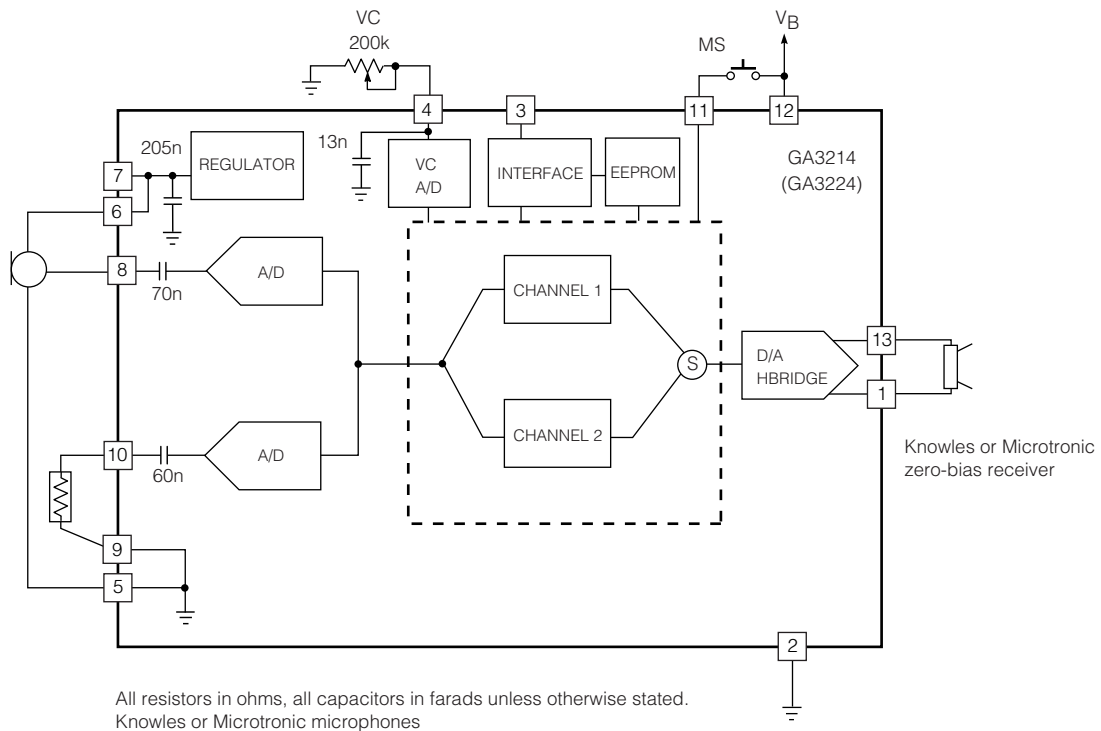

Figure 2: Typical Application Circuit

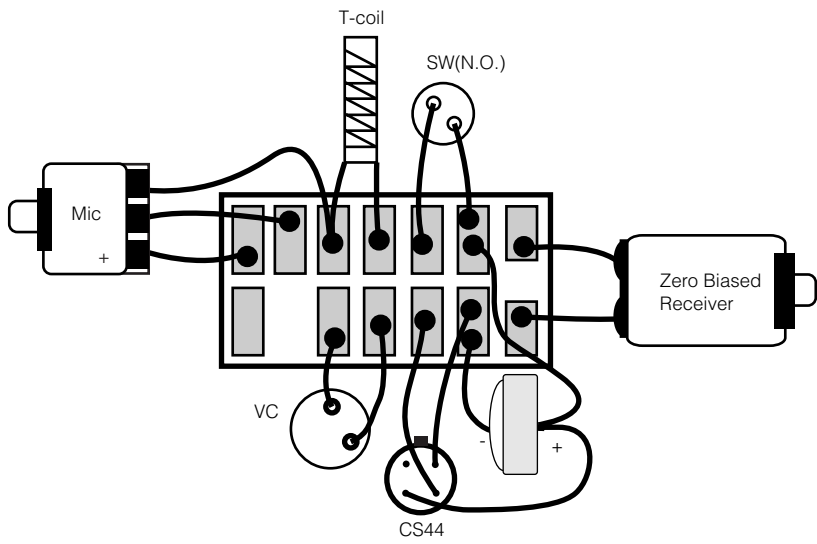
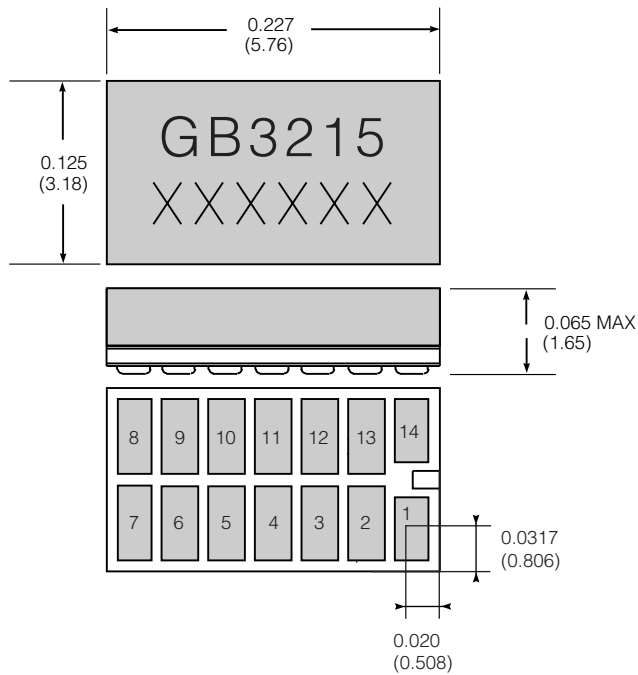

Figure 3: Assembly Diagram

**PACKAGE DIMENSIONS**



Dimension units are in inches.  
 Dimensions in parentheses are in millimetres, converted from inches and include minor rounding errors.  
 1.0000 inches = 25.400mm  
 Dimension tolerances: ±0.003 (±0.08) unless otherwise stated.  
 Work order number: XXXXXX  
 This Hybrid is designed for either point-to-point manual soldering or for reflow according to Gennum's reflow process (Information Note 521-45).

**PAD LOCATION**

PAD NO.	PAD POSITION		PAD DIMENSION		
	X	Y	Xdim	Ydim	
1	0	0	23.0	40.5	MIL
2	-31.5	3	24.0	46.5	
3	-63.0	3	23.0	46.5	
4	-94.0	3	23.0	46.5	
5	-125.0	3	23.0	46.5	
6	-156.0	3	23.0	46.5	
7	-187.0	3	23.0	46.5	
8	-187.0	64.5	23.0	46.5	
9	-156.0	64.5	23.0	46.5	
10	-125.0	64.5	23.0	46.5	
11	-94.0	64.5	23.0	46.5	
12	-63.0	64.5	23.0	46.5	
13	-31.5	64.5	24.0	46.5	
14	0	67.5	23.0	40.5	
1	0	0	0.584	1.029	mm
2	-0.800	0.076	0.584	1.181	
3	-1.600	0.076	0.584	1.181	
4	-2.388	0.076	0.584	1.181	
5	-3.175	0.076	0.584	1.181	
6	-3.962	0.076	0.584	1.181	
7	-4.750	0.076	0.584	1.181	
8	-4.750	0.076	0.584	1.181	
9	-3.962	1.638	0.584	1.181	
10	-3.175	1.638	0.584	1.181	
11	-2.388	1.638	0.610	1.181	
12	-1.600	1.638	0.584	1.181	
13	-0.800	1.638	0.584	1.181	
14	0	1.715	0.584	1.029	

GB3215 / GB3225

**DOCUMENT IDENTIFICATION**  
 PRELIMINARY DATA SHEET  
 The product is in a preproduction phase and specifications are subject to change without notice.

**REVISION NOTES:**  
 GB3225 hybrid code changed.  
 For latest product information, visit [www.gennum.com](http://www.gennum.com)

**GENNUM CORPORATION**

MAILING ADDRESS:  
 P.O. Box 489, Stn. A, Burlington, Ontario, Canada L7R 3Y3  
 Tel. +1 (905) 632-2996 Fax. +1 (905) 632-5946

SHIPPING ADDRESS:  
 970 Fraser Drive, Burlington, Ontario, Canada L7L 5P5

**GENNUM JAPAN CORPORATION**

Shinjuku Green Tower Building 27F, 6-14-1, Nishi Shinjuku,  
 Shinjuku-ku, Tokyo, 160-0023 Japan  
 Tel. +81 (03) 3349-5501, Fax. +81 (03) 3349-5505

Gennum Corporation assumes no responsibility for the use of any circuits described herein and makes no representations that they are free from patent infringement.  
 © Copyright February 2002 Gennum Corporation. All rights reserved. Printed in Canada.