

NEW

X-CUBE COMPACT X-RAY CCD CAMERAS

H8480 Series

SAMPLE X-RAY IMAGES

Sample: Digital camera memory media

X-ray tube voltage: 80 kV p

X-ray tube current: 100 μ A

H8480

Effective area: ϕ 25 mm Min.

Resolution : 8 Lp/mm

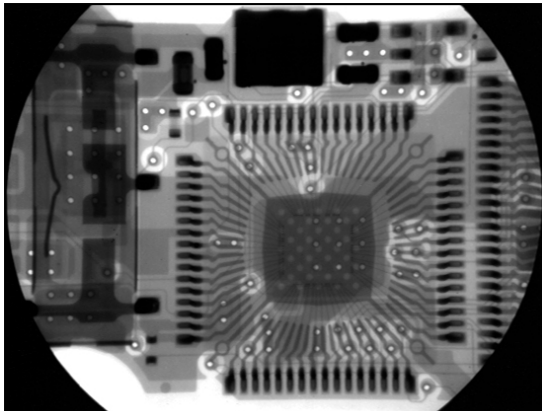

Sample: MEMORY STICK®

H8481

(High Resolution Type)

Effective area: 8.8 mm \times 6.6 mm

Resolution : 13 Lp/mm

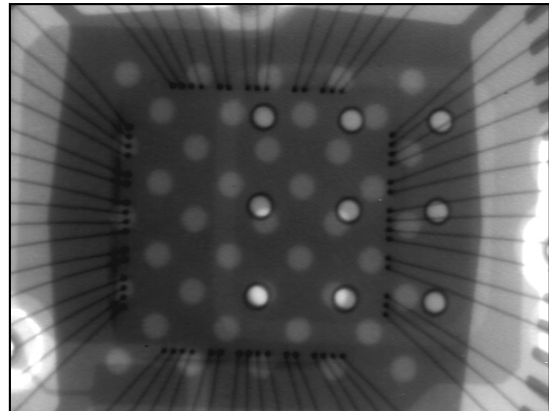

OVER VIEW

X-CUBE is a compact X-ray CCD camera designed for non-destructive inspection. Using a general-purpose CCD chip mounted in a rugged but lightweight camera head, X-CUBE makes X-ray imaging as easy as handling ordinary CCD cameras.

There are two different models in the X-CUBE family - the H8480 and H8481. The H8480 uses a 2/3-inch CCD coupled to a large-diameter tapered FOP. This FOP is coated with CsI, the next generation of X-ray scintillators, and offers a large effective area of 25 mm diameter and a resolution of 8 Lp/mm. The H8481 uses a straight type FOP instead of the large FOP, achieving a high resolution of 13 Lp/mm.

This easy-to-use, compact and lightweight X-ray CCD camera will let you create totally new types of non-destructive inspections.

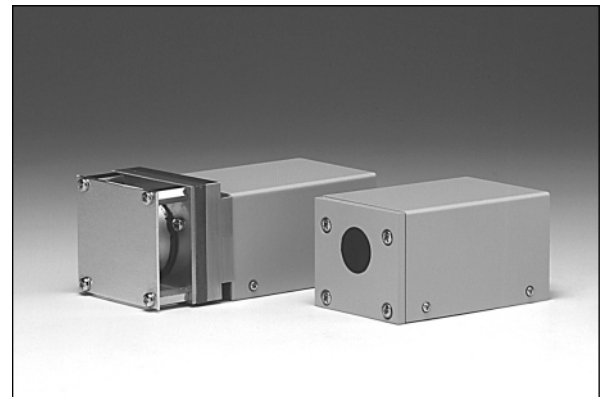

▲Left: H8480, Right: H8481

FEATURES

- Effective area: ϕ 25 mm Min. (H8480)
- High resolution: 13 Lp/mm (H8481)
- High sensitivity: CsI scintillator
- Compact
- Low power consumption

HAMAMATSU

SAMPLE X-RAY IMAGES

H8480

(Effective area: $\phi 25$ mm Min.)

H8481

(High Resolution Type)

(Effective area: 8.8 mm \times 6.6 mm)

● IC telephone card

X-ray tube voltage: 75 kV p

X-ray tube current: 100 μ A

Visible image

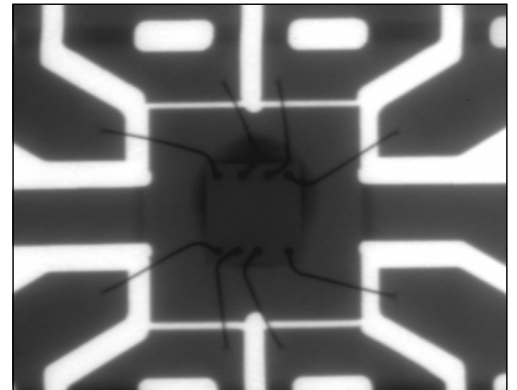
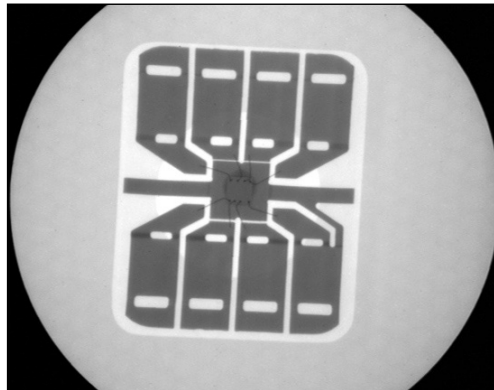

● Seeds

X-ray tube voltage: 40 kV p

X-ray tube current: 100 μ A

Visible image

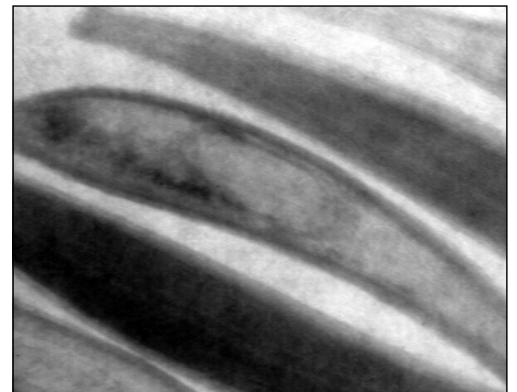
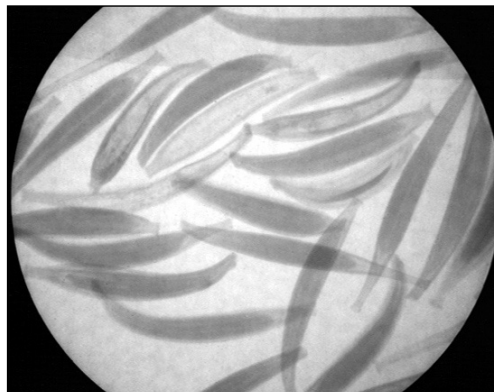

X-RAY IMAGE COMPARISON (with GOS sheet)

● A phantom of a finger

X-ray tube voltage: 70 kV p

X-ray tube current: 100 μ A

X-CUBE

(CsI scintillator)

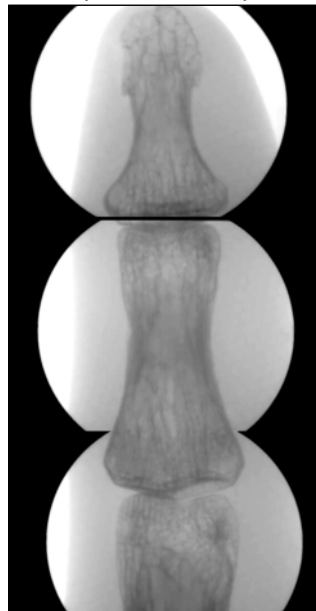

Conventional device

(GOS sheet)

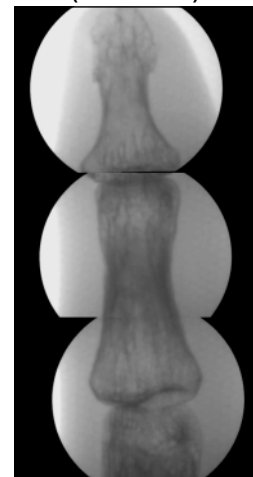

SPECIFICATIONS

GENERAL RATINGS

Parameter	H8480-03	H8480-04	H8481-05	H8481-06
Effective area	φ25 mm Min.		8.8 mm × 6.6 mm	
Resolution	8 Lp/mm		13 Lp/mm	
TV method	EIA	CCIR	EIA	CCIR
Imaging sensor	Interline transfer 2/3-inch CCD image sensor			
Number of pixels	768 (H) × 494 (V)	752 (H) × 582 (V)	768 (H) × 494 (V)	752 (H) × 582 (V)
Scanning method	Interlace/ Non-interlace			
Sync. method	Auto selection by the input signal			
External sync. signal input	S. VS (SYNC level 0.3 V), HD/VD (2 V to 5 V)			
Video signal output	1.0 V p-p (negative sync., 75 Ω, unbalanced)			
Power supply voltage (DC)	+12.0 V ± 3.0 V			
Power consumption	Approx. 1.6 W			
γ correction	0.45/1.0 (internal switching)			
Gain	AGC/FIX/MANUAL (selection from rear panel)			
Shutter speed	1/60 s to 1/10 000 s (7-step internal switching)			
Operating temperature	-5 °C to 45 °C			
Storage temperature	-10 °C to 60 °C			
Operating humidity	Below 80 % (non condensation)			

DIMENSIONAL OUTLINE (Unit: mm)

H8480

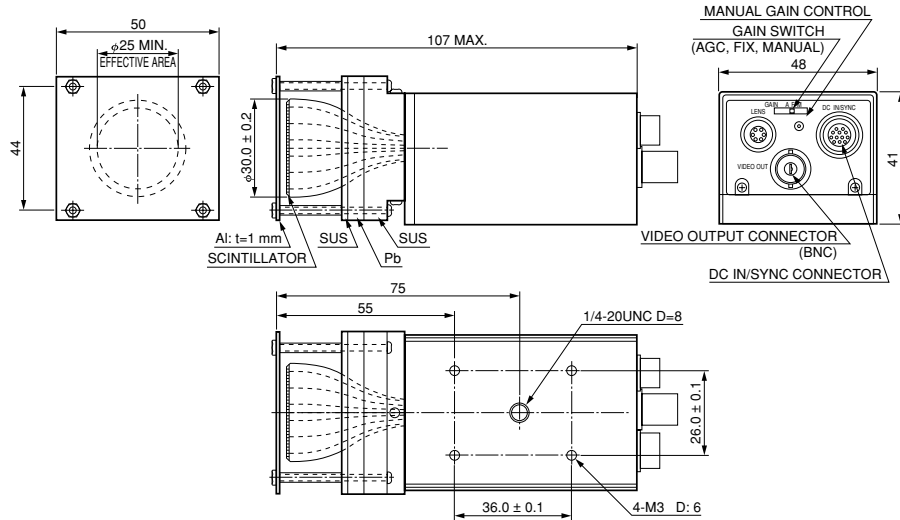

TMCPA0051EA

H8481

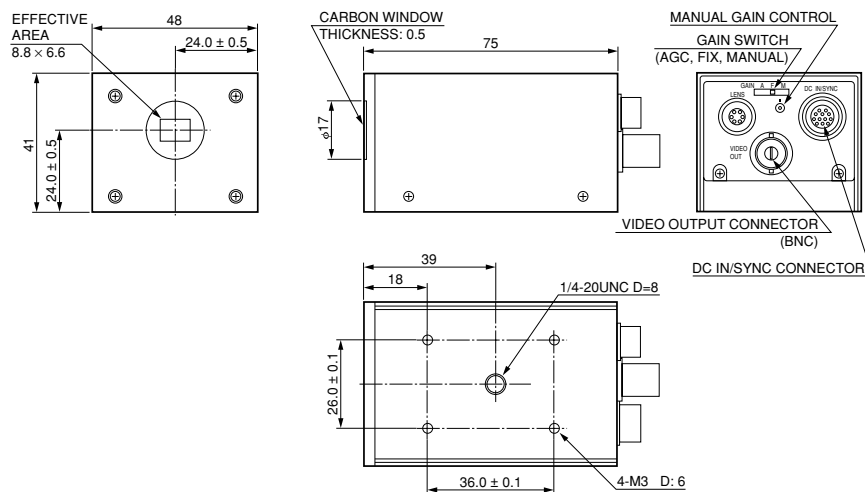

TMCPA0052EA

OPTIONS (sold separately)

- CCD camera power supply
- Camera cable
- AC adapter

RELATED PRODUCTS

●FOS (Fiber optic plate coated with X-ray scintillator)

The FOS is an optical device for X-ray imaging, fabricated by coating an X-ray scintillator material over a fiber optic plate consisting of tens of million glass fibers each a few micrometers in diameter. The FOS provides higher sensitivity and resolution than currently used sensitized paper films and also allows real-time digital radiography when directly coupled to a commercially available CCD. The fiber optic plate used in the FOS has excellent X-ray absorption characteristics, so that X-rays penetrating the X-ray scintillator and directly entering the CCD are minimized to less than 1 %. This protects the CCD from the deterioration and increased noise caused by X-ray irradiation, assuring a long service life and maintaining high image quality. Various sizes and shapes of FOS are available to meet your particular needs, including tapered FOP types.

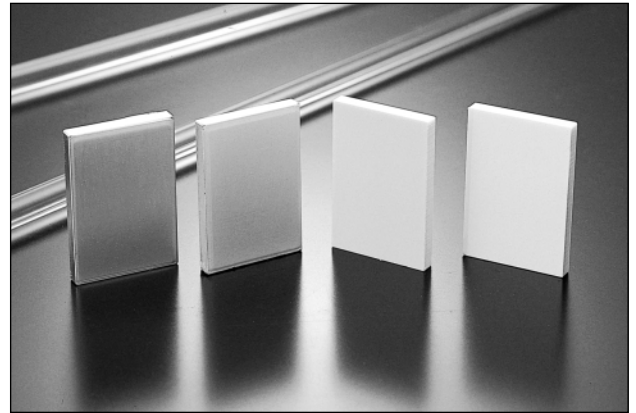

■Structure

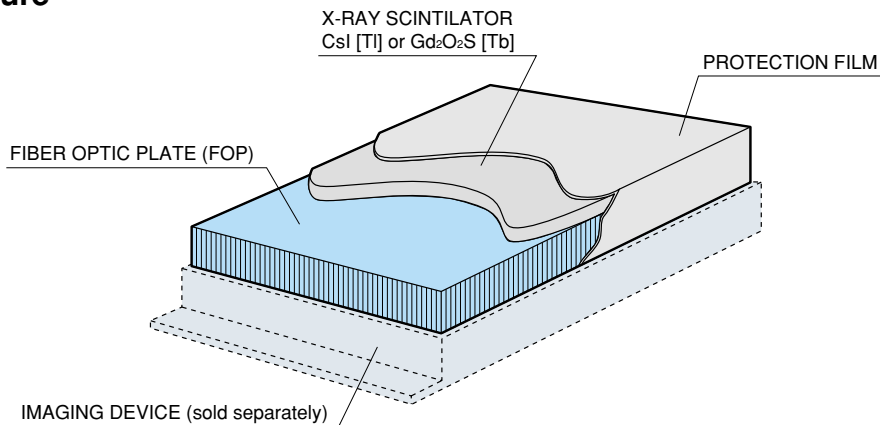

★ "MEMORY STICK" is trademark of Sony Corporation.

Subject to local technical requirements and regulations, availability of products included in this promotional material may vary. Please consult with our sales office.
Information furnished by HAMAMATSU is believed to be reliable. However, no responsibility is assumed for possible inaccuracies or omissions. Specifications are subject to change without notice. No patent rights are granted to any of the circuits described herein. ©2001 Hamamatsu Photonics K.K.

HAMAMATSU

HOME PAGE URL <http://www.hamamatsu.com>

HAMAMATSU PHOTONICS K.K., Electron Tube Center

314-5, Shimokanzo, Toyooka-village, Iwata-gun, Shizuoka-ken, 438-0193, Japan, Telephone: (81)539/62-5248, Fax: (81)539/62-2205

U.S.A.: Hamamatsu Corporation: 360 Foothill Road, P. O. Box 6910, Bridgewater, N.J. 08807-0910, U.S.A., Telephone: (1)908-231-0960, Fax: (1)908-231-1218 E-mail: usa@hamamatsu.com

Germany: Hamamatsu Photonics Deutschland GmbH: Arzbergerstr. 10, D-82211 Herrsching am Ammersee, Germany, Telephone: (49)8152-375-0, Fax: (49)8152-2658 E-mail: info@hamamatsu.de

France: Hamamatsu Photonics France S.A.R.L.: 8, Rue du Saule Trapu, Parc du Moulin de Massy, 91882 Massy Cedex, France, Telephone: (33)1 69 53 71 00, Fax: (33)1 69 53 71 10 E-mail: infos@hamamatsu.fr

United Kingdom: Hamamatsu Photonics UK Limited: 2 Howard Court, 10 Tewin Road Welwyn Garden City Hertfordshire AL7 1BW, United Kingdom, Telephone: 44-(0)1707-294888, Fax: 44(0)1707-325777 E-mail: info@hamamatsu.co.uk

North Europe: Hamamatsu Photonics Norden AB: Smidesvägen 12, SE-171-41 SOLNA, Sweden, Telephone: (46)8-509-031-00, Fax: (46)8-509-031-01 E-mail: info@hamamatsu.se

Italy: Hamamatsu Photonics Italia: S.R.L.: Strada della Moia, 1/E, 20020 Arese, (Milano), Italy, Telephone: (39)02-935 81 733, Fax: (39)02-935 81 741 E-mail: info@hamamatsu.it

TMCP1029E02
JUN. 2001 IP
(1000)