

General Purpose PNP Epitaxial Planar Transistors

(dual transistors)

HBP2907S6R

Features

- Two BTP2907 chips in a SOT-363 package.
- Mounting possible with SOT-323 automatic mounting machines.
- Transistor elements are independent, eliminating interference.
- Mounting cost and area can be cut in half.
- Excellent H_{FE} linearity.
- Complementary to HBN2222S6R.
- Pb-free package

Equivalent Circuit

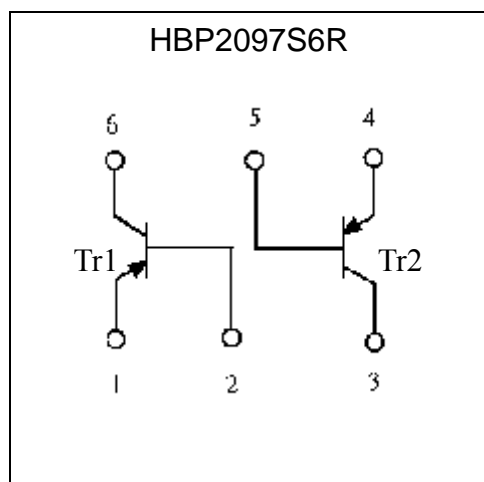

Outline

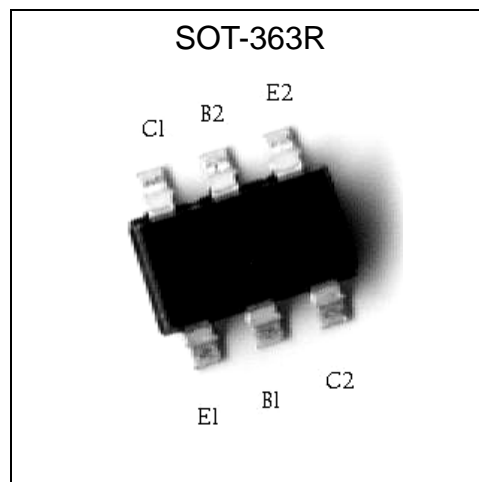

The following characteristics apply to both Tr1 and Tr2

Absolute Maximum Ratings ($T_a=25^{\circ}C$)

Parameter	Symbol	Limits	Unit
Collector-Base Voltage	V_{CB0}	-60	V
Collector-Emitter Voltage	V_{CE0}	-60	V
Emitter-Base Voltage	V_{EB0}	-5	V
Collector Current	I_C	-600	mA
Power Dissipation	P_d	200(total) (Note)	mW
Junction Temperature	T_j	150	$^{\circ}C$
Storage Temperature	T_{stg}	-55~+150	$^{\circ}C$

Note: 150mW per element must not be exceeded.



Characteristics (Ta=25°C)

Symbol	Min.	Typ.	Max.	Unit	Test Conditions
BVCBO	-60	-	-	V	IC=-100μA
BVCEO	-60	-	-	V	IC=-10mA
BVEBO	-6	-	-	V	IE=-10μA
ICBO	-	-	-10	nA	VCB=-50V
ICEX	-	-	-50	nA	VCE=-30V, VBE(OFF)=-0.5V
*VCE(sat)	-	-0.2	-0.4	V	IC=-150mA, IB=-15mA
*VCE(sat)	-	-0.5	-1.6	V	IC=-500mA, IB=-50mA
*VBE(sat)	-	-	-1.3	V	IC=-150mA, IB=-15mA
*VBE(sat)	-	-	-2.6	V	IC=-500mA, IB=-50mA
*hFE 1	75	-	-	-	VCE=-10V, IC=-100μA
*hFE 2	100	-	-	-	VCE=-10V, IC=-1mA
*hFE 3	100	-	-	-	VCE=-10V, IC=-10mA
*hFE 4	100	-	300	-	VCE=-10V, IC=-150mA
*hFE 5	50	-	-	-	VCE=-10V, IC=-500mA
fT	200	-	-	MHz	VCE=-20V, IC=-50mA, f=100MHz
Cob	-	-	8	pF	VCB=-30V, IE=0A, f=1MHz

*Pulse Test: Pulse Width ≤380μs, Duty Cycle ≤2%

Ordering Information

Device	Package	Shipping	Marking
HBP2907S6R	SOT-363 (Pb-free)	3000 pcs / Tape & Reel	2F



Characteristic curves

Current Gain vs Collector Current

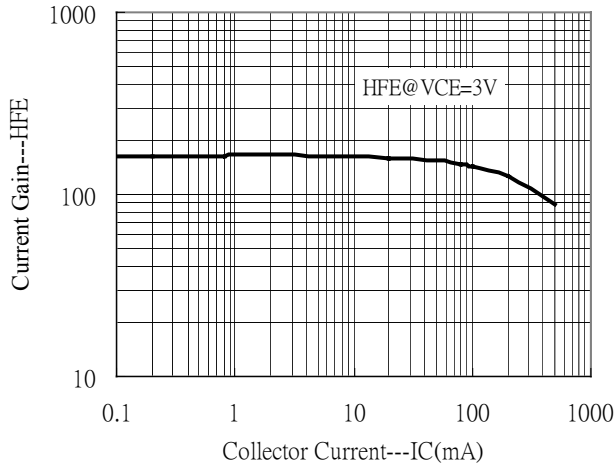

Saturation Voltage vs Collector Current

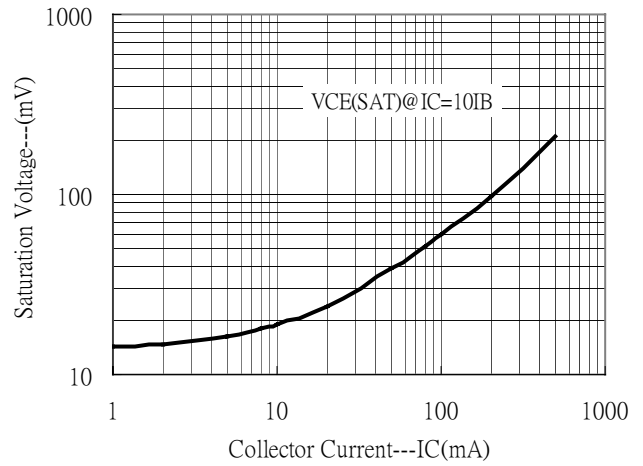

Saturation Voltage vs Collector Current

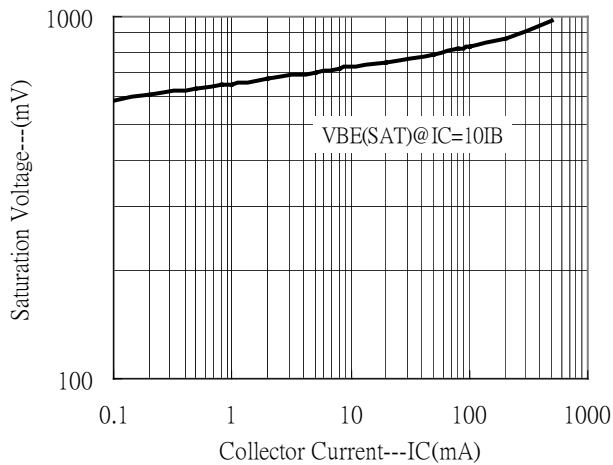

Cutoff Frequency vs Collector Current

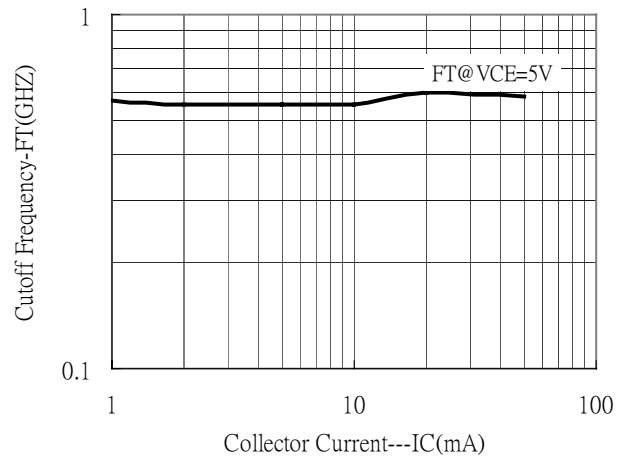

Power Derating Curves

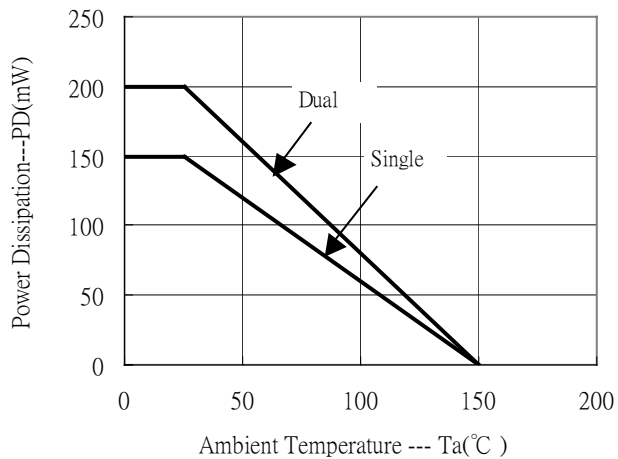

Reel Dimension

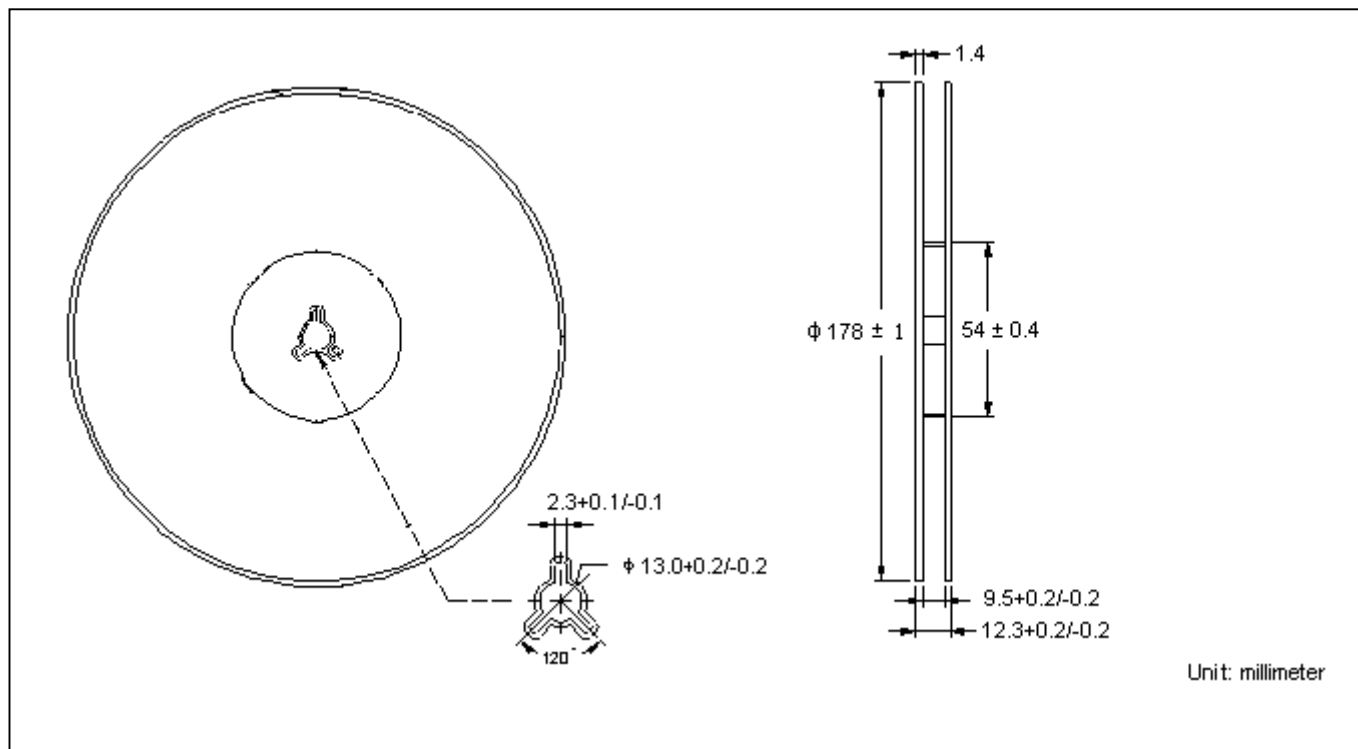

Carrier Tape Dimension

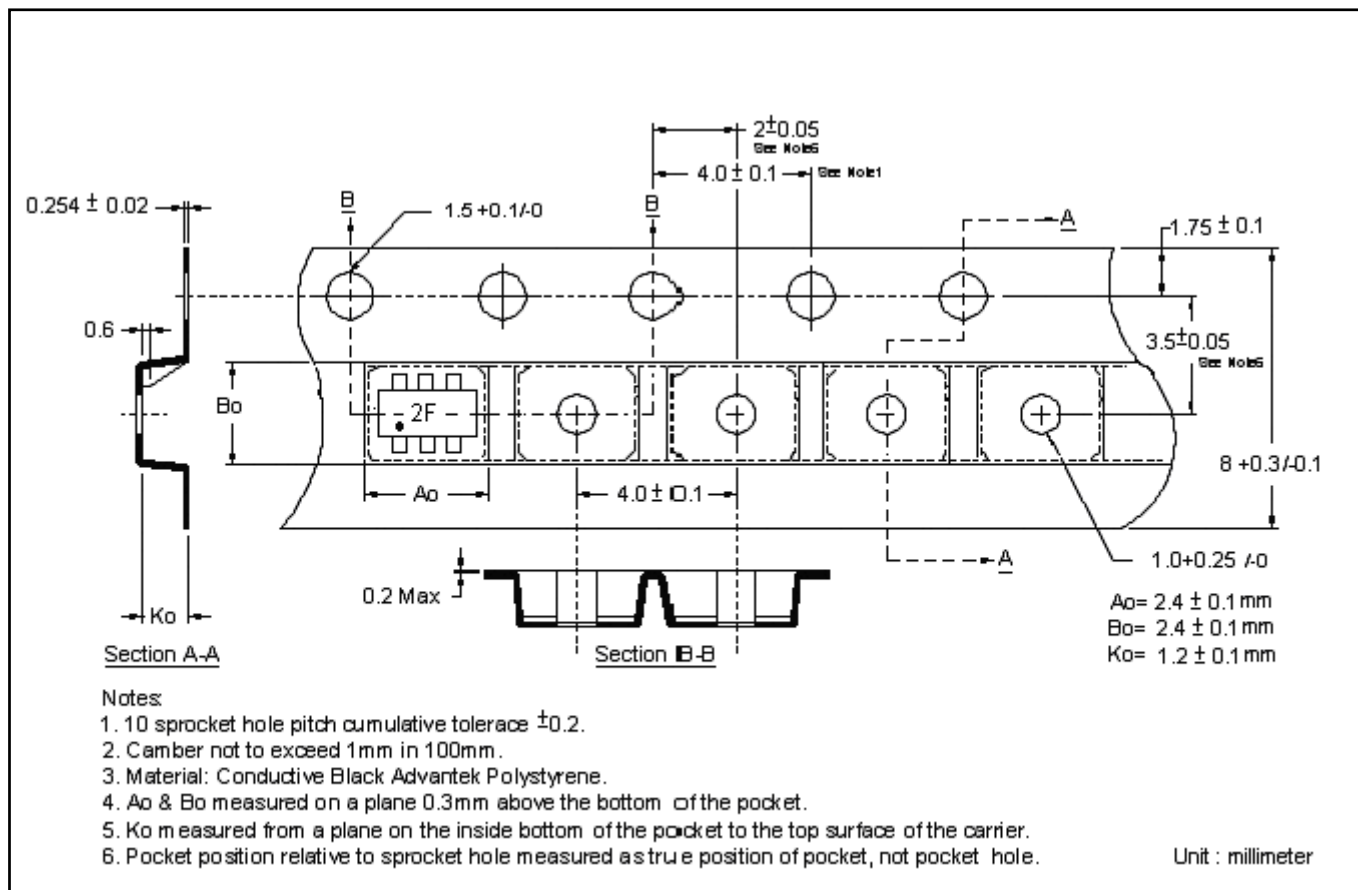

SOT-363R Dimension

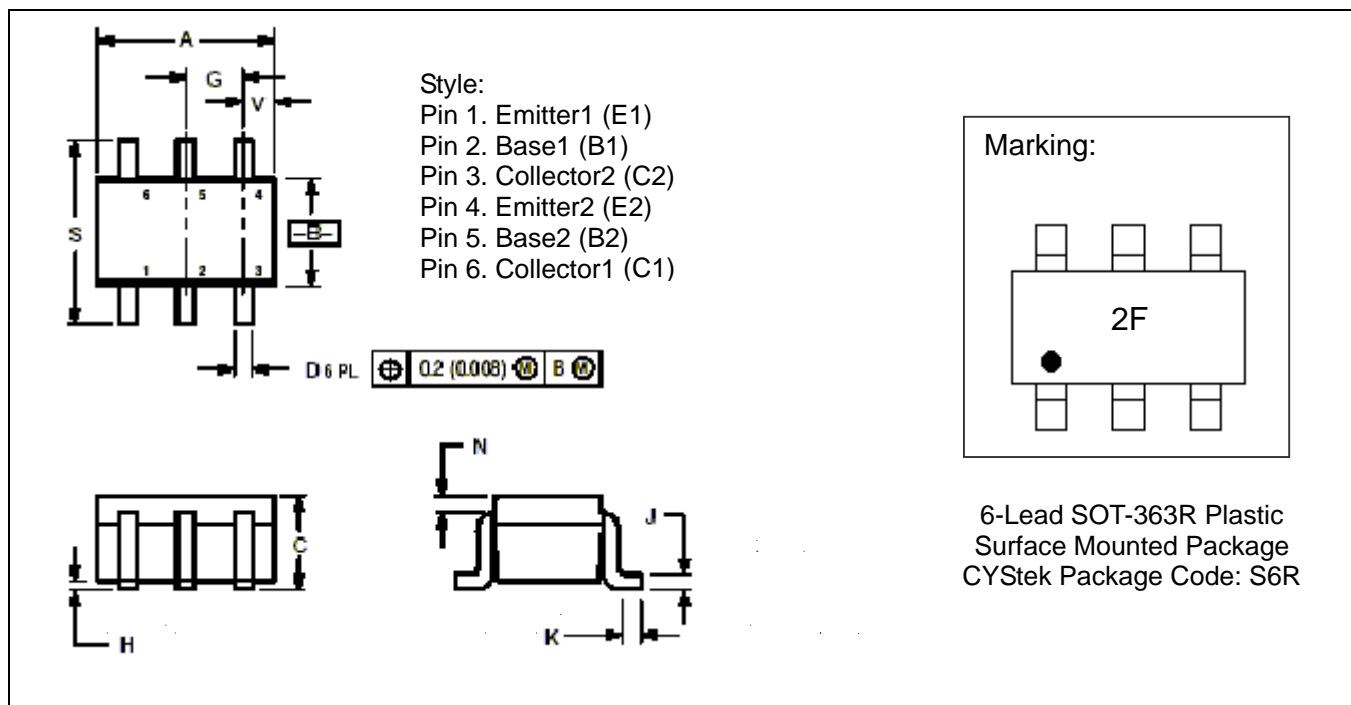

*:Typical

DIM	Inches		Millimeters		DIM	Inches		Millimeters	
	Min.	Max.	Min.	Max.		Min.	Max.	Min.	Max.
A	0.071	0.087	1.8	2.2	J	0.004	0.010	0.1	0.25
B	0.045	0.053	1.15	1.35	K	0.004	0.012	0.1	0.30
C	0.031	0.043	0.8	1.1	N	0.008 REF		0.20 REF	
D	0.004	0.012	0.1	0.3	S	0.079	0.087	2.00	2.40
G	0.026BSC		0.65BSC		Y	0.012	0.016	0.30	0.40
H	-	0.004	-	0.1					

- Notes : 1.Controlling dimension : millimeters.
 2.Maximum lead thickness includes lead finish thickness, and minimum lead thickness is the minimum thickness of base material.
 3.If there is any question with packing specification or packing method, please contact your local CYStek sales office.

Material :

- Lead : 42 Alloy ; solder plating
- Mold Compound : Epoxy resin family, flammability solid burning class:UL94V-0

Important Notice:

- All rights are reserved. Reproduction in whole or in part is prohibited without the prior written approval of CYStek.
- CYStek reserves the right to make changes to its products without notice.
- CYStek **semiconductor products are not warranted to be suitable for use in Life-Support Applications, or systems.**
- CYStek assumes no liability for any consequence of customer product design, infringement of patents, or application assistance.