

**SANYO**

No. 3782A

**LB1810M**

**Spindle Motor Driver  
for Floppy-disk Drives**

**OVERVIEW**

The LB1810M is a three-phase, full-wave spindle motor driver IC that features digital speed control, making it ideal for use in 3.5-inch floppy-disk drives. It can be used in most disk drives without output electrolytic capacitors.

The LB1810M incorporates both active-HIGH and active-LOW start/stop control inputs, a revolution detector, Hall-effect transducer amplifiers with AGC, thermal protection and index delay circuits, and a single-sided hysteresis index comparator.

The LB1810M operates from either a 4.2 to 6.5 V or 10.2 to 13.8 V supply and is available in 44-pin QIPs.

**FEATURES**

- Three-phase, full-wave motor driver
- Digital speed control
- Both active-HIGH and active-LOW start/stop control inputs
- Revolution detector
- Hall-effect transducer amplifiers with AGC
- Thermal protection circuit
- Single-sided hysteresis index comparator
- Index delay circuit
- 4.2 to 6.5 V or 10.2 to 13.8 V supply
- 44-pin QIP

**PINOUT**

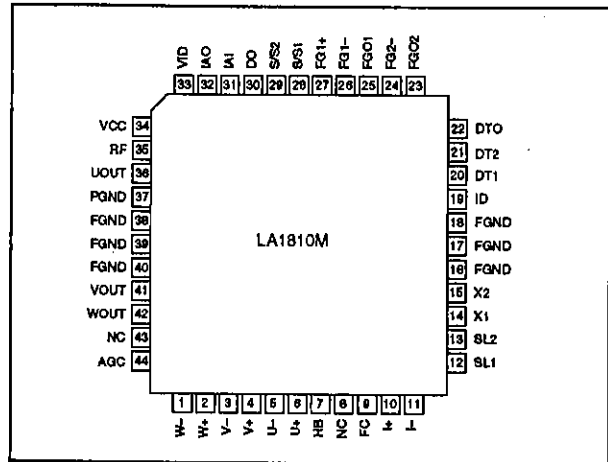

**PACKAGE DIMENSIONS**

Unit: mm

3148-QIP44MA

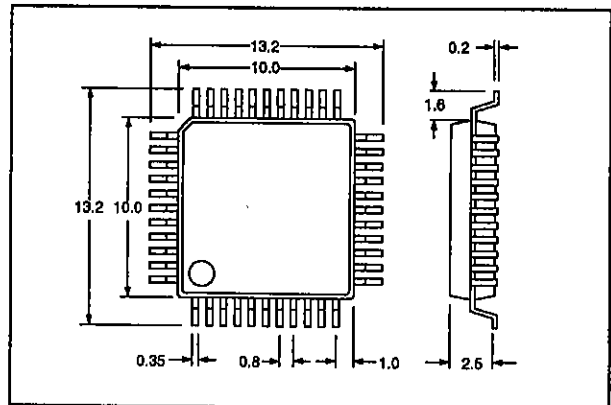

**BLOCK DIAGRAM**

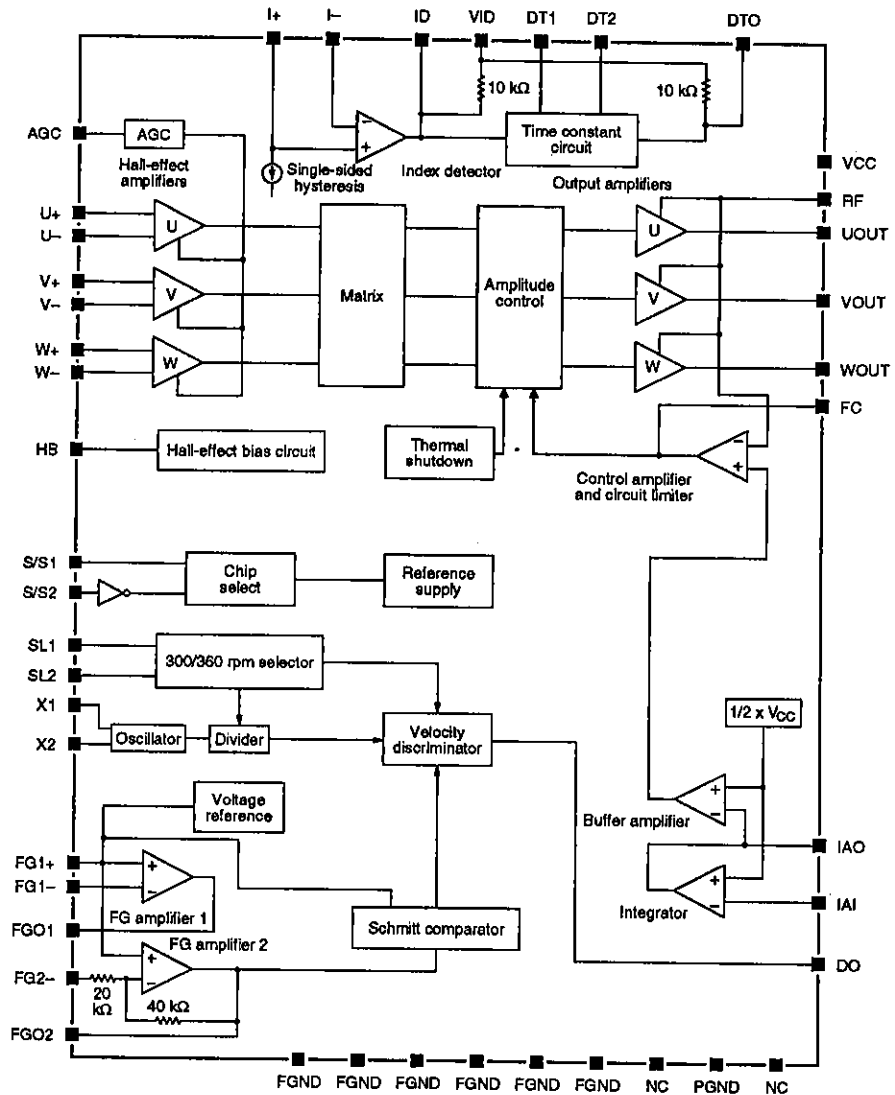

**PIN DESCRIPTION**

Number	Name	Description
1	W-	W-phase Hall-effect transducer amplifier inputs
2	W+	
3	V-	V-phase Hall-effect transducer amplifier inputs
4	V+	
5	U-	U-phase Hall-effect transducer amplifier inputs
6	U+	
7	HB	Hall-effect transducer bias voltage output
8, 43	NC	No connection
9	FC	Frequency compensation capacitor connection
10	I+	Index detector Hall-effect transducer amplifier inputs
11	I-	

## LB1810M

Number	Name	Description
12	SL1	300/360 rpm speed select inputs
13	SL2	
14	X1	Crystal oscillator connections
15	X2	
16 to 18 and 38 to 40	FGND	Frame ground
19	ID	Index pulse output
20	DT1	Delay time-constant setting external network connections
21	DT2	
22	DT0	Index delay pulse output
23	FGO2	FG amplifier 2 output
24	FG2-	FG amplifier 2 inverting input
25	FGO1	FG amplifier 1 output
26	FG1-	FG amplifier 1 inverting input
27	FG1+	FG amplifier 1 non-inverting input
28	S/S1	Start/stop circuit control inputs
29	S/S2	
30	DO	Discriminator output
31	IAI	Integrating amplifier input
32	IAO	Integrating amplifier output
33	VID	5 V index delay circuit supply
34	VCC	4.2 to 6.5 V or 10.2 to 13.8 V supply
35	RF	Output amplifier supply
36	UOUT	U-phase output
37	PGND	Power ground
41	VOUT	V-phase output
42	WOUT	W-phase output
44	AGC	Automatic gain control circuit capacitor connection

## SPECIFICATIONS

### Absolute Maximum Ratings

Parameter	Symbol	Rating	Unit
Supply voltage	V <sub>CC</sub>	14.5	V
Output current	I <sub>o</sub>	1 (t ≤ 0.5 s)	A
		0.7	
Power dissipation	P <sub>D</sub>	1000	mW
Operating temperature range	T <sub>opr</sub>	-20 to 80	°C
Storage temperature range	T <sub>stg</sub>	-40 to 125	°C

LB1810M

Recommended Operating Conditions

$T_a = 25\text{ }^\circ\text{C}$

Parameter	Symbol	Rating	Unit
Supply voltage	$V_{CC}$	5 or 12	V
Supply voltage range	$V_{CC}$	4.2 to 6.5 or 10.2 to 13.8	V

Electrical Characteristics

$V_{CC} = 12\text{ V}$ ,  $T_a = 25\text{ }^\circ\text{C}$  unless otherwise noted

Parameter	Symbol	Condition	Rating			Unit
			min	typ	max	
Quiescent supply current	$I_{CCO}$	$V_{CC} = 5\text{ V}$ , motor stopped	-	-	0.2	mA
		$V_{CC} = 12\text{ V}$ , motor stopped	-	-	0.5	
Supply current	$I_{CC}$	$V_{CC} = 5\text{ V}$ , motor running	-	20	30	mA
		$V_{CC} = 12\text{ V}$ , motor running	-	22	33	
SL1 and SL2 360-rpm select input voltage	$V_{SLL}$		0	-	0.8	V
SL1 and SL2 300-rpm select input voltage	$V_{SLH}$		2	-	$V_{CC}$	V
SL1 and SL2 input bias current	$I_{SL}$		-	-	0.4	mA
S/S1 stop voltage	$V_{S/S1L}$		0	-	0.8	V
S/S1 start voltage	$V_{S/S1H}$		2	-	$V_{CC}$	V
S/S1 input bias current	$I_{S/S1}$		-	-	0.4	mA
S/S2 start voltage	$V_{S/S2L}$		0	-	0.8	V
S/S2 stop voltage	$V_{S/S2H}$		2	-	$V_{CC}$	V
Hall-effect transducer amplifier common-mode input voltage	$V_H$		2.2	-	$V_{CC} - 0.7$	V
Hall-effect transducer amplifier differential input voltage	$V_{df}$		70	-	200	mV <sub>pp</sub>
Hall-effect transducer amplifier input offset voltage	$V_{HO}$	See note.	-	-	$\pm 10$	mV
Hall-effect transducer amplifier input bias current	$I_{HB}$		-	-	20	$\mu\text{A}$
HB output voltage	$V_H$	$I_H = 5\text{ mA}$	-	1.5	1.8	V
HB output leakage current	$I_{HL}$	Motor stopped	-	-	$\pm 10$	$\mu\text{A}$
UOUT, VOUT and WOUT source or sink output saturation voltage	$V_{sat}$	$I_o = 0.35\text{ A}$ , $V_{CC} = 4.2\text{ V}$	-	1.2	1.4	V
		$I_o = 0.7\text{ A}$ , $V_{CC} = 4.2\text{ V}$	-	1.5	2.0	V
UOUT, VOUT and WOUT output leakage current	$I_{OL}$		-	-	$\pm 1$	mA
Current limiter reference voltage	$V_{ref1}$		0.27	0.30	0.33	V
Control amplifier voltage gain	$G_C$		-	-6	-	dB
Control amplifier interphase voltage gain differential	$\Delta G_C$		-	-	$\pm 1$	dB
Integrating amplifier reference voltage	$V_{ref2}$		-	$0.5V_{CC}$	-	V
Integrating amplifier bias current	$I_b$		-	-	$\pm 1$	$\mu\text{A}$

LB1810M

Parameter	Symbol	Condition	Rating			Unit
			min	typ	max	
Integrating amplifier output voltages	$V_{I+}$	Referenced to $V_{ref2}$ , $I_i = -0.5$ mA	-	0.75	-	V
	$V_{I-}$	Referenced to $V_{ref2}$ , $I_i = 0.5$ mA	-	-1.4	-	V
Amplifier gain bandwidth	BW	See note.	-	1	-	MHz
FG amplifier 1 input voltage	$V_{FG1}$		2	-	40	mV <sub>pp</sub>
FG amplifier 1 voltage gain	$G_{FG1}$	Output open. See note.	-	60	-	dB
FG amplifier 1 input offset voltage	$V_{FG10}$		-	-	$\pm 10$	mV
FG amplifier 2 input voltage	$V_{FG2}$		1	-	$V_{CC} - 1$	V
FG amplifier 2 voltage gain	$G_{FG2}$		-	6	-	dB
FG amplifier 2 input offset voltage	$V_{FG20}$		-	-	$\pm 10$	mV
FG amplifiers internal reference voltage	$V_{FGB}$	$V_{CC} = 5$ V	2.2	2.5	2.8	V
		$V_{CC} = 12$ V	5.3	5.9	6.5	
Schmitt-trigger voltage hysteresis	$\Delta V_{sh}$	LOW-to-HIGH and HIGH-to-LOW. See note.	-	25	-	mV
Schmitt-trigger input voltage	$V_{sh}$		1	-	$V_{CC} - 1$	V
Discriminator levels	N		-	1024	-	levels
Discriminator LOW-level voltage	$V_{DL}$	$I_D = -0.5$ mA	-	-	0.3	V
Discriminator HIGH-level voltage	$V_{DH}$	$I_D = 0.5$ mA	$V_{CC} - 0.4$	-	-	V
Discriminator leakage current	$I_{D1}$		-	-	$\pm 1$	$\mu$ A
Discriminator operating frequency	$f_D$	See note.	-	-	1	MHz
Oscillator frequency	$f_{osc}$	See note.	-	-	1	MHz
Index detector Hall-effect transducer amplifier phase input voltage	$V_{ID}$		1.5	-	$V_{CC} - 0.5$	V
Index detector Hall-effect transducer amplifier input bias current	$I_{IDB}$		-	-	$\pm 10$	$\mu$ A
Induction current for hysteresis	$I_{IDO}$		5	10	15	$\mu$ A
Index detector LOW-level output voltage	$V_{IDL}$	$V_{ID} = 5$ V	-	-	0.4	V
Index detector HIGH-level output voltage	$V_{IDH}$	$V_{ID} = 5$ V	4.5	-	-	V
Index delay circuit discharge voltage	$V_{DLDC}$	$V_{ID} = 5$ V	-	2.5	-	V
Index delay circuit LOW-level output voltage	$V_{DLL}$	$V_{ID} = 5$ V	-	-	0.4	V
Index delay circuit HIGH-level output voltage	$V_{DLH}$	$V_{ID} = 5$ V	4.5	-	-	V
Thermal shutdown temperature	TSD	See note.	150	180	-	$^{\circ}$ C
Thermal shutdown temperature hysteresis	$\Delta TSD$	See note.	-	40	-	$^{\circ}$ C

Note

These values are calculated ratings only and are not measured.

## Typical Performance Characteristics

### Maximum power dissipation vs. ambient temperature

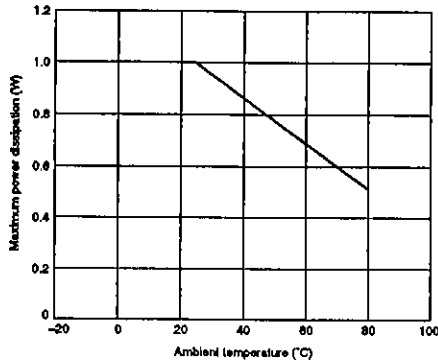

## FUNCTIONAL DESCRIPTION

### Digital Speed Control

The motor speed is given by the equation

$$f_{FG} = \frac{f_{osc} \times D}{1024}$$

where  $f_{FG}$  is the revolution detector frequency,  $f_{osc}$  is the crystal oscillator frequency and  $D$  is the frequency-divider constant. When  $SL1$  is HIGH,  $D$  is 5/8, and when LOW,  $D$  is 6/8.

### Output Phase Control

The motor driver output source and sink phases are selected by the voltages on the Hall-effect transducer amplifier inputs for each phase as shown in table 1. Note that a Hall-effect transducer amplifier input is HIGH when the voltage on the positive input exceeds the voltage on the negative input.

Table 1. Source and sink phase selection

Source phase	Sink phase	Hall-effect transducer amplifier inputs		
		U	V	W
V	W	HIGH	HIGH	LOW
V	U	LOW	HIGH	LOW
W	U	LOW	HIGH	HIGH
W	V	LOW	LOW	HIGH
U	V	HIGH	LOW	HIGH
U	W	HIGH	LOW	LOW

TYPICAL APPLICATION

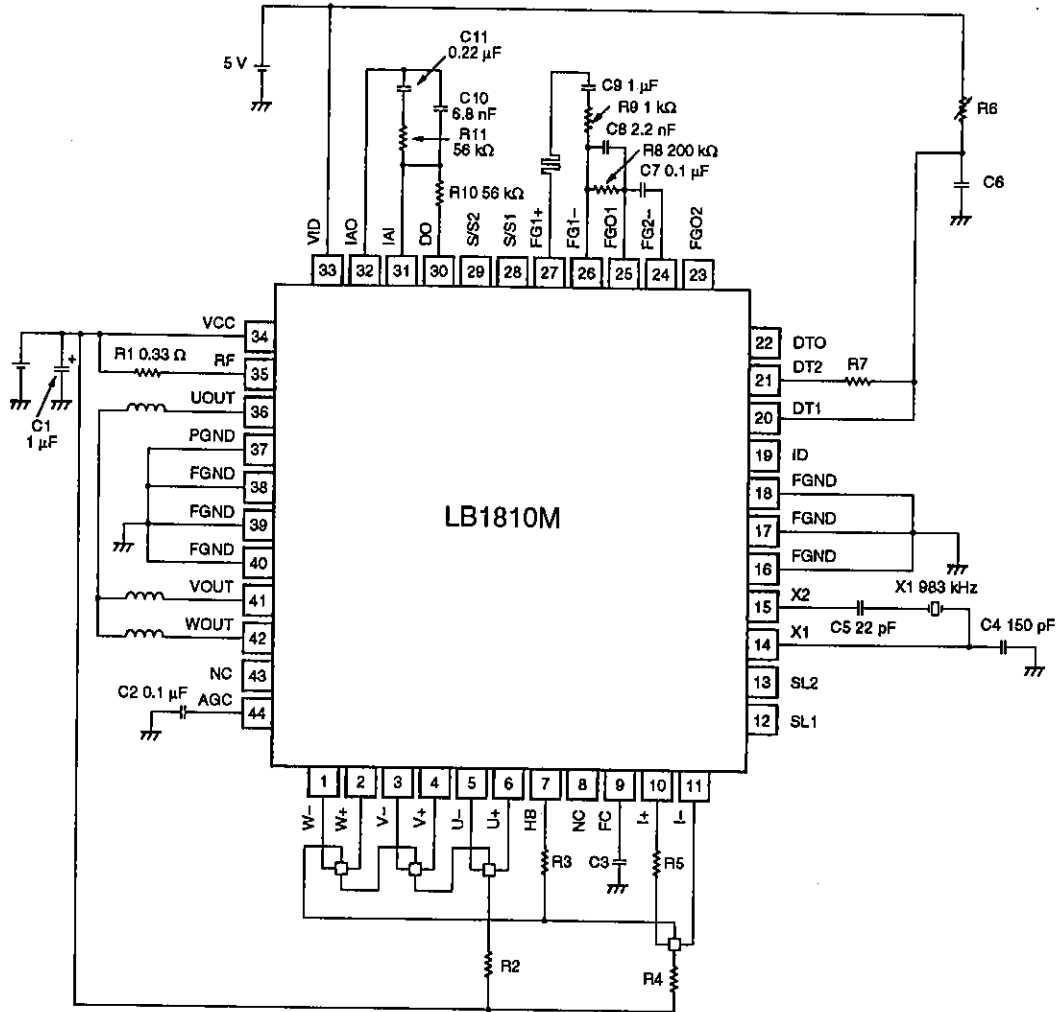

Note

Component values are for example only. Exact values will depend upon the motor characteristics.

- No products described or contained herein are intended for use in surgical implants, life-support systems, aerospace equipment, nuclear power control systems, vehicles, disaster/crime-prevention equipment and the like, the failure of which may directly or indirectly cause injury, death or property loss.
- Anyone purchasing any products described or contained herein for an above-mentioned use shall:
  - ① Accept full responsibility and indemnify and defend SANYO ELECTRIC CO., LTD., its affiliates, subsidiaries and distributors and all their officers and employees, jointly and severally, against any and all claims and litigation and all damages, cost and expenses associated with such use;
  - ② Not impose any responsibility for any fault or negligence which may be cited in any such claim or litigation on SANYO ELECTRIC CO., LTD., its affiliates, subsidiaries and distributors or any of their officers and employees jointly or severally.
- Information (including circuit diagrams and circuit parameters) herein is for example only; it is not guaranteed for volume production. SANYO believes information herein is accurate and reliable, but no guarantees are made or implied regarding its use or any infringements of intellectual property rights or other rights of third parties.