

To all our customers

---

## **Regarding the change of names mentioned in the document, such as Mitsubishi Electric and Mitsubishi XX, to Renesas Technology Corp.**

---

The semiconductor operations of Hitachi and Mitsubishi Electric were transferred to Renesas Technology Corporation on April 1st 2003. These operations include microcomputer, logic, analog and discrete devices, and memory chips other than DRAMs (flash memory, SRAMs etc.) Accordingly, although Mitsubishi Electric, Mitsubishi Electric Corporation, Mitsubishi Semiconductors, and other Mitsubishi brand names are mentioned in the document, these names have in fact all been changed to Renesas Technology Corp. Thank you for your understanding. Except for our corporate trademark, logo and corporate statement, no changes whatsoever have been made to the contents of the document, and these changes do not constitute any alteration to the contents of the document itself.

Note : Mitsubishi Electric will continue the business operations of high frequency & optical devices and power devices.

Renesas Technology Corp.  
Customer Support Dept.  
April 1, 2003

# M63016FP

## Spindle Motor AND 4CH ACTUATOR Drive IC

### [FEATURES]

This IC is 1 chip driver IC for Spindle Motor and 4 channel actuators. All of the Motor and actuator of optical disk drive system (CD-ROM etc.) can be driven by only this IC. This IC has current control drive system for Focus, Tracking, Spindle and Slide channel drive, also has a direct PWM control system for Spindle and Slide channels drive due TO reducing IC power dissipation. This IC has three voltage supply terminals(for Spindle, Slide/Loading and Focus/Tracking), and three voltage supply can be set separately. Further more this IC has an operational amplifier for Slide input, FG amplifier, thermal shut down circuit, standby circuit, channel SELECT function,reverse rotation detect circuit and Short braking SELECT.

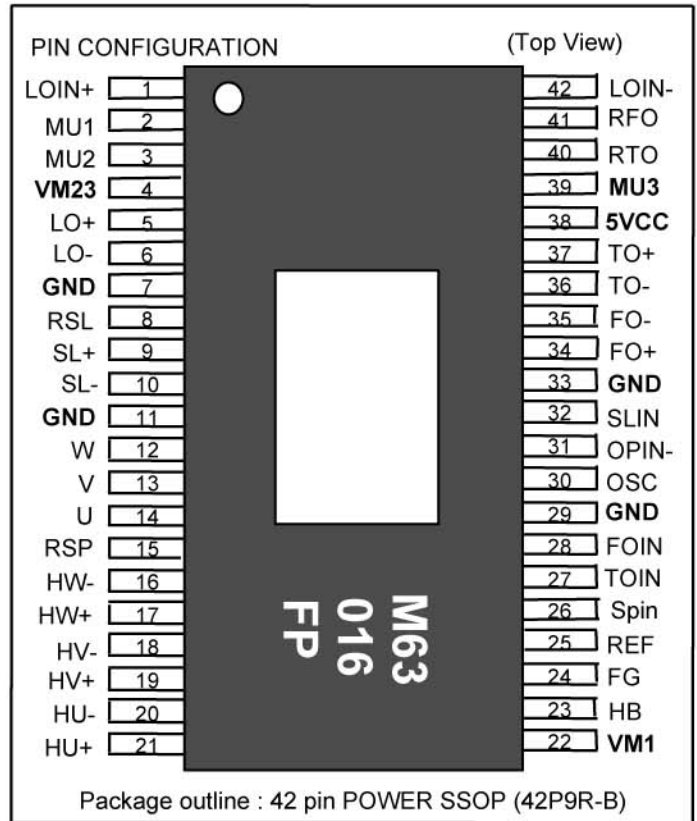

### [APPLICATION]

CD-ROM, DVD, DVD-ROM, DVD-RAM, Optical disc related system, etc

### [BLOCK DIAGRAM]

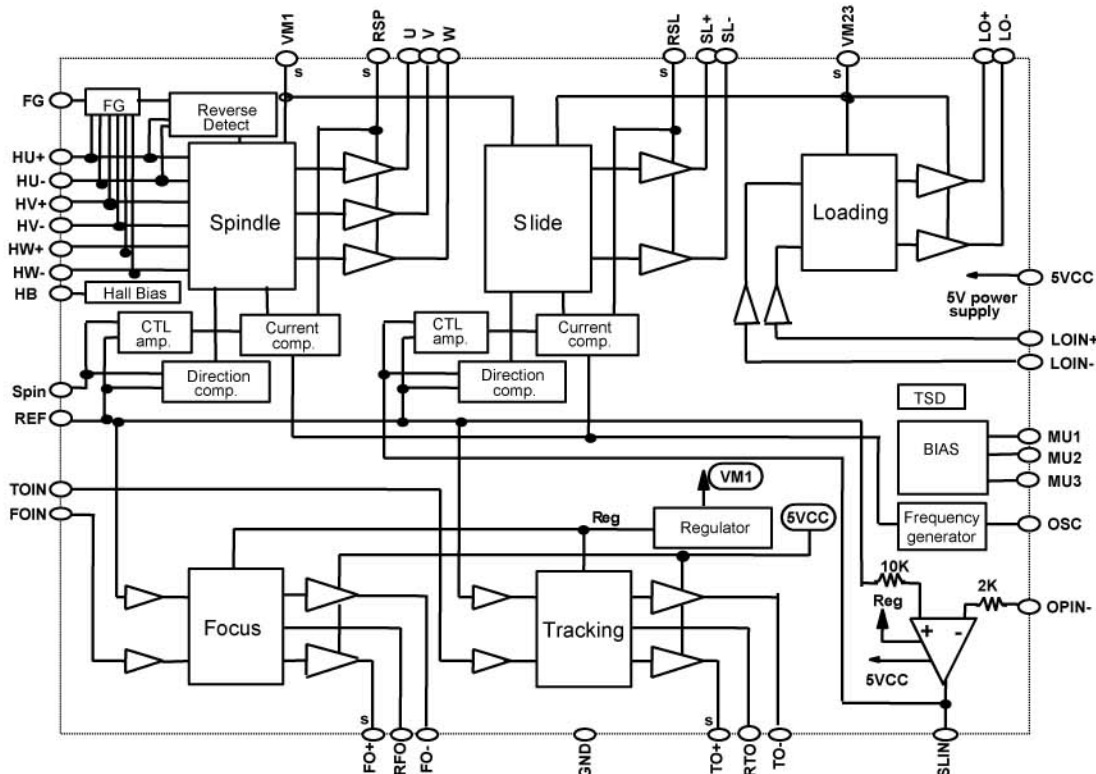

**M63016FP****Spindle Motor AND 4CH ACTUATOR Drive IC**

## [PIN FUNCTION]

TERMINAL	SYMBOL	TERMINAL FUNCTION	TERMINAL	SYMBOL	TERMINAL FUNCTION
1	LOIN +	Loading control input (+)	42	LOIN -	Loading control input (- )
2	MU1	mute 1	41	RFO	Current feedback terminal for Focus
3	MU2	mute 2	40	RTO	Current feedback terminal for Tracking
4	VM23	Motor Power Supply 3(for Slide/Loading)	39	MU3	mute 3
5	LO+	Loading non-inverted output	38	5VCC	5V Power Supply (for FS and TS)
6	LO-	Loading inverted output	37	TO+	Tracking non-inverted output
7	GND	GND	36	TO-	Tracking inverted output
8	RSL	Slide current sense	35	FO-	Focus inverted output
9	SL+	Slide non-inverted output	34	FO+	Focus non-inverted output
10	SL-	Slide inverted output	33	GND	GND
11	GND	GND	32	SLIN	Slide control input
12	W	Motor drive output W	31	OPIN-	Operational amplifier inverted input
13	V	Motor drive output V	30	OSC	PWM carrier oscillation set
14	U	Motor drive output U	29	GND	GND
15	RSP	Spindle current sense	28	FOIN	Focus control voltage input
16	HW-	HW- sensor amp. input	27	TOIN	Tracking control voltage input
17	HW+	HW+ sensor amp. input	26	Spin	Spindle control voltage input
18	HV-	HV- sensor amp. input	25	REF	Reference voltage input
19	HV+	HV+ sensor amp. input	24	FG	Frequency generator output
20	HU-	HU- sensor amp. input	23	HB	Bias for Hall Sensor
21	HU+	HU+ sensor amp. input	22	VM1	Motor Power Supply 1 (for Spindle)

\*The M63016FP is possible to same function M63015FP when 39pin terminal(MU3) connect to 5V.

**M63016FP****Spindle Motor AND 4CH ACTUATOR Drive IC**

[ ABSOLUTE MAXIMUM RATING] (Ta=25°C)

SYMBOL	PARAMETER	CONDITIONS	RATING	Unit
5VCC	5V power supply	Focus and Tracking power supply	7	V
VM1	Motor power supply 1	Spindle power supply	15	V
VM23	Motor power supply 23	Slide and Loading power supply	15	V
Io A	Motor Output Current A	Spindle output current with external shottky diode *note 1	1.5	A
Io B	Motor Output Current B	Slide output current with external shottky diode *note 1	1.2	A
Io C	Motor Output Current C	Focus,Tracking and Loading output current *note 1	1.0	A
VIN	maximum input voltage of terminals	MU1,MU2,MU3,Hw-,Hw+,Hv-,Hv+,Hu-,Hu+,REF, Spin,TOIN,FOIN,OSC,Opin -,LOIN -,LOIN+	0 ~ 5VCC	V
Pt	Power dissipation	Free Air and on the grass epoxy board	2.6	W
Kθ	Thermal derating	Free Air and on the grass epoxy board	20.8	mW / °C
Tj	Junction temperature		150	°C
To pr	Operating temperature		-20 ~ +75	°C
Tstg	Storage temperature		-40 ~ +150	°C

**\*note1** ; The ICs must be operated within the Pt (power dissipation) or the area of safety operation  
The Spindle and Slide output terminal is needed external shottky diode between each output and GND  
when it is used above 0.6A. Description(IoA) is case of with external shottky diode.  
(The Schottky diodes are not necessary IN some application. )

[ RECOMMENDED OPERATING CONDITIONS] (Ta=25°C)

SYMBOL	PARAMETER	LIMITS			Unit
		minimum	typical	maximum	
VM 1	VM1 power supply (for Spindle)	6	12	13.2	V
VM 23	VM23 power supply (for Slide and Loading)	4.5	12	13.2	V
5VCC	5V power supply (for Focus and Tracking)	4.5	5	7	V
IoA,B	Spindle and Slide Output Current *note2	—	0.5	1.0	A
Io C	Focus, Tracking and Loading Output Current	—	0.5	0.8	A
Fosc	PWM carrier frequency	30	—	120	KHz

**\*note2** ; The Spindle and Slide output terminal is needed external shottky diode between each output and GND  
when it is used above 0.6A. Description(IoA) is case of with external shottky diode.  
(The Shottky diodes are not necessary IN some application. )

# M63016FP

## Spindle Motor AND 4CH ACTUATOR Drive IC

### [ THERMAL DERATING ]

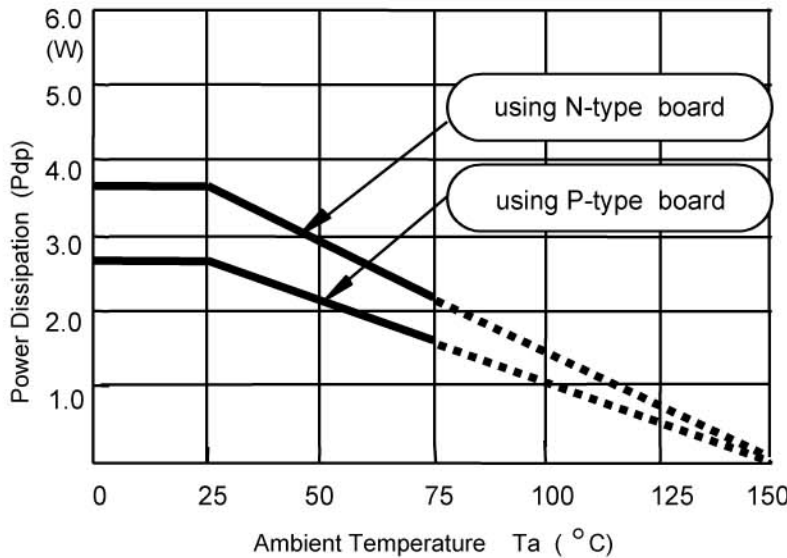

This IC's package is POWER-SSOP, so improving the board on which the IC is mounted enables a large power dissipation without a heat sink.

For example, using an 1 layer glass epoxy resin board, the IC's power dissipation is 2.6W at least. And it comes to 3.6W by using an improved 2 layer board.

The information of the N, P type board is shown in attached.

### [ ELECTRICAL CHARACTERISTICS ]

#### Common

(Ta=25°C, 5VCC=5V, VM1=VM23=12V unless otherwise noted.)

SYMBOL	PARAMETER	CONDITIONS	LIMITS			Unit	
			MIN	TYP	MAX		
Icc1	Supply current	5VCC, VM1, VM23 current	at LOIN+=LOIN-	—	44	60	mA
			at LOIN+=LOIN-=0V	—	35	50	
Icc2	Sleep current	5VCC, VM1, VM23 current under Sleep (MU1 = MU2 = 0V).	—	—	30	u A	
Fosc	PWM carrier frequency	OSC : with 180 pF	—	110	—	KHz	
VINOP	OPamp input voltage range	Opin -	0	—	5	V	
IINOP	OPamp input current	Opin - = 1.65V	-1.0	-0.15	0	u A	
V of OP	OPamp input offset voltage	REF=1.65V(Opin- = OPOUT; buffer)	-10	—	+10	mV	
V out OP	Opamp output voltage range	Io= -2.0 ~ +2.0mA	0.5	—	4.5	V	
VINREF	REF input voltage range		1.0	—	3.3	V	
IINREF	REF input current	VREF=1.65V	-10	—	+10	u A	
VMULO	MUTE terminal Low voltage	MU1, MU2, MU3	—	—	0.8	V	
VMUHI	MUTE terminal high voltage	MU1, MU2, MU3	3.0	—	—	V	
IMU	Mute terminal input current	MU1, MU2, MU3 at 5V input voltage	—	—	500	u A	

# M63016FP

## Spindle Motor AND 4CH ACTUATOR Drive IC

[ ELECTRICAL CHARACTERISTICS ]

**Spindle**

(Ta=25 °C, 5VCC=5V, VM1=VM23=12V unless otherwise noted.)

SYMBOL	PARAMETER	CONDITIONS	LIMITS			Unit
			MIN	TYP	MAX	
Vdyc 1	Dynamic range of output	Io=0.5 [A]	10.5	11.0	—	V
Vdead1-	Control voltage dead zone 1	Spin<REF [REVERSE]	-80	-40	0	mV
Vdead1+		REF<Spin [FORWARD]	0	+40	+80	mV
VIN1	Control voltage input range 1	Spin	0	—	5	V
Gvo1	Control gain 1	Gio1=Gvo1/ Rs [A/V]	0.85	1.0	1.15	V/V
Vlim1F	Control limit 1F	Ilim1F= Vlim1F/ Rs [A] [FORWARD] at MU3=5V	0.4	0.5	0.6	V
Vlim2F	Control limit 2F	Ilim2F= Vlim2F/ Rs [A] [FORWARD] at MU3=0V	0.27	0.34	0.41	V
Vlim1R	Control limit 1R	Ilim1R= Vlim1R/ Rs [A] [REVERSE]	0.27	0.34	0.41	V
VHcom	Hall sensor amp. common mode input range	Hu+,Hu-,Hv+,Hv-,Hw+,Hw-	1.3	—	3.7	V
VH min	Hall sensor amp. input signal level	Hu+,Hu-,Hv+,Hv-,Hw+,Hw-	60	—	—	mVp-p
VHB	HB output voltage	at Load current (IHB)=10mA	0.6	0.85	1.2	V
IHB	HB terminal sink current		—	—	30	mA

**Slide**

(Ta=25 °C, 5VCC=5V, VM1=VM23=12V unless otherwise noted.)

SYMBOL	PARAMETER	CONDITIONS	LIMITS			Unit	
			MIN	TYP	MAX		
Vdyc 2	Dynamic range of output	Io=0.5 [A] VM1=12[V]	at VM23=5[V]	3.8	4.2	—	V
			at VM23=12[V]	10.3	10.8	—	
Vdead2-	Control voltage dead zone 2	SLIN < REF	-80	-40	0	mV	
Vdead2+		REF < SLIN	0	+40	+80	mV	
VIN2	Control voltage input range 2	SLIN	0	—	5	V	
Gvo2	Control gain 2	Gio2=Gvo2/ Rs [A/V]	0.85	1.0	1.15	V/V	
Vlim2	Control limit 2	Ilim2=Vlim2/ Rs [A]	0.43	0.5	0.58	V	
Tdon	Output turn-on delay	Time after RS is greater than an input instruction value, while an output turns on.	—	1.0	2.0	u sec	
Tdoff	Output turn-off delay	Time after RS is less than an input instruction value, while an output turns off.	—	3.5	7.0	u sec	
Tdsw	Output switching delay	All output off time at the time of the output drive direction change.	—	5.0	10.0	u sec	
Ileak	Output leak current	MU1=MU2=MU3=0V	-100	—	100	u A	

**M63016FP****Spindle Motor AND 4CH ACTUATOR Drive IC****[ELECTRICAL CHARACTERISTICS]****Loading**

(Ta=25°C, 5VCC=5V, VM1=VM23=12V unless otherwise noted.)

SYMBOL	PARAMETER	CONDITIONS	LIMITS			Unit	
			MIN	TYP	MAX		
Vdyc 3	Dynamic range of output	Io=0.5[A]	VM23=5[V]	3.3	3.8	—	V
			VM23=12[V]	10.3	10.8	—	
VIN 3	Control voltage input range3	LOIN+, LOIN-	0	—	5	V	
Gvo3	Control gain 3	$\frac{(LO+) - (LO-)}{(LOIN+) - (LOIN-)}$	16.6	18	19.3	dB	
Voff 1	Output offset voltage	(LO+) - (LO-)	(LOIN+)= (LOIN-)=5V	-100	0	+100	mV
			(LOIN+)= (LOIN-)=1.65V	-50	0	+50	mV
VinOff	Channel off voltage	LOIN+, LOIN-[Both input voltage]	—	0.4	0.5	V	

**Focus / Tracking**

(Ta=25°C, 5VCC=5V, VM1=VM23=12V unless otherwise noted.)

SYMBOL	PARAMETER	CONDITIONS	LIMITS			Unit
			MIN	TYP	MAX	
Vdyc4	Dynamic range of output	Io=0.5[A] 5VCC=5[V]	3.8	4.2	—	V
VIN 4	Control voltage input range4	FOIN, TOIN	0	—	5	V
Gvo 4	Control gain 4	$\frac{RFO(RTO) - FO-(TO-)}{FOIN(TOIN) - REF}$	-6.7	-8.0	-9.4	dB
Voff 2	Output offset voltage	RFO (RTO) - FO - (TO - ) at REF=FOIN(TOIN)=1.65V	-5	0	+5	mV

**[ THERMAL CHARACTERISTICS]**

SYMBOL	PARAMETER	FUNCTION START TEMPERATURE OF IC			FUNCTION STOP TEMPERATURE OF IC			Unit
		MIN	TYP	MAX	MIN	TYP	MAX	
TSD	Thermal Shut Down	—	160	—	—	130	—	°C

# M63016FP

## Spindle Motor AND 4CH ACTUATOR Drive IC

### Channel SELECT function

	Logic control			Drive channel						Current limit (Spin>REF)	Brake SELECT (Spin<REF)	
	MU1	MU2	MU3	Loading	Slide	Focus	Tracking	Spindle	OP amp			
SELECT1	L	L	H	Off	Off	Off	Off	Off	Off	Off	--	--
SELECT2	H	L	H	On	On	On	On	On	On	On	100%	PWM
SELECT3	L	H	H	On	Off	On	On	On	On	On	100%	Short
SELECT4	H	H	H	On	On	On	On	On	On	On	100%	Short
SELECT5	L	L	L	Off	Off	Off	Off	Off	Off	Off	--	--
SELECT6	H	L	L	On	On	On	On	On	On	On	68%	PWM
SELECT7	L	H	L	On	Off	On	On	On	On	On	68%	Short
SELECT8	H	H	L	On	On	On	On	On	On	On	68%	Short

This IC has three MUTE terminal (MU1 , MU2 and MU3).

It is possible to control ON / OFF of each channel by external Logic inputs.

It has eight kinds of function for SELECT. In case of SELECT1 and SELECT5, the bias of all circuit becomes OFF.

Therefore, this mode is available in order to reduce the power dissipation when the waiting mode.

In case of SELECT2, it is possible to SELECT the PWM reverse braking to take the brake of Spindle Motor.

Also, in case of SELECT4, it is possible to SELECT the short braking when in the same.

In case of SELECT3, it is possible to do OFF the Slide channel

Regard with making OFF the Loading channel in case of SELECT2, SELECT3 and SELECT4, please refer to

[Loading channel]. In case of SELECT6, SELECT7 and SELECT8 it is possible to SELECT the 68% current limit under acceleration.

Therefore, this mode is available in order to reduce a temperature under acceleration.

### Loading channel

The Loading channel is the circuit of BTL voltage drive.

This circuit has the referential input. Output swing is determined with  $\Delta VIN \times 8$ . Also, it is possible for this channel to use for the Slide Motor, the Focus coil and the Tracking coil.

The input terminal is high impedance.

It is possible to do variable a gain by external resistor.

The output becomes high impedance in case of both input voltage becomes under 0.5 volts.

It is possible for the input terminal to operate from 0 volts.

The following table and diagram show an application in case of two MCU port and one MCU port for the Loading Motor.

In case of one MCU port, if use three state port, it is possible for this channel to have the stop function.

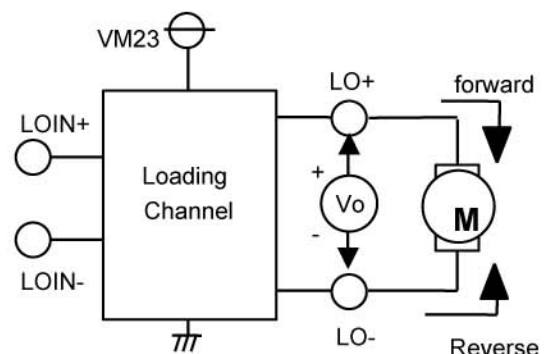



# M63016FP

## Spindle Motor AND 4CH ACTUATOR Drive IC

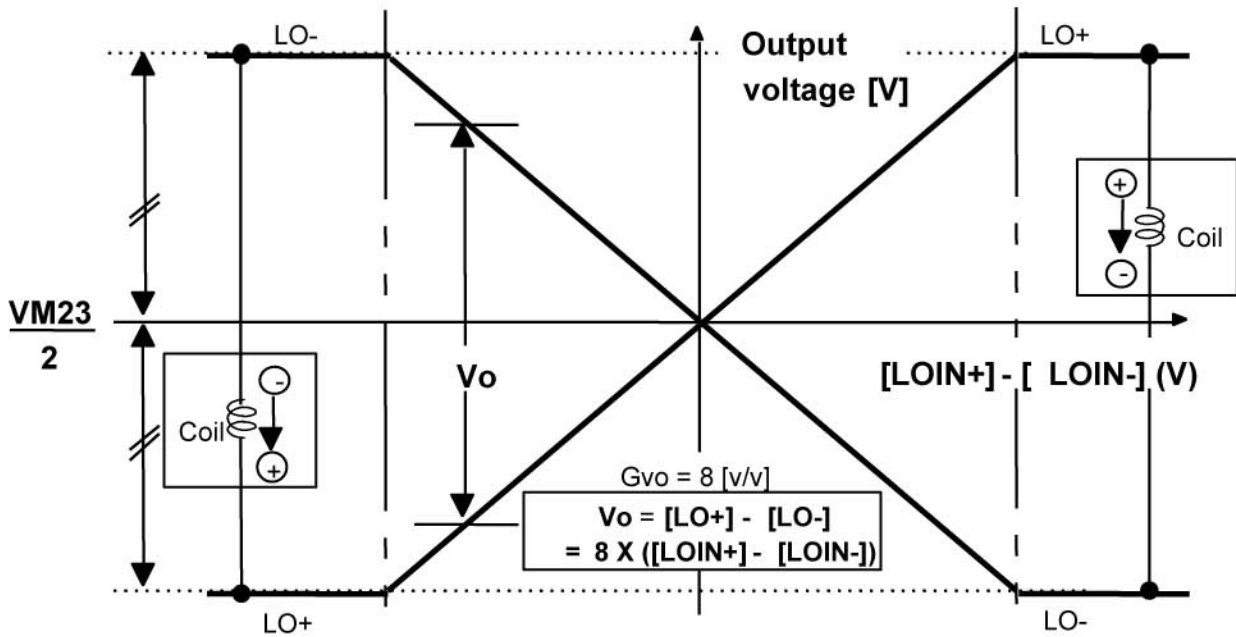

application.1: Two port H/L control

Logic control		Situation of Loading channel	Output voltage swing
P1	P2		
5V	5V	Short brake --> Stop	$V_o = 0 [V]$
0	5V	Reverse rotation	$V_o = - 8 \times 5 \times R1 / (R1 + 2 \times R2)$
5V	0	Forward rotation	$V_o = 8 \times 5 \times R1 / (R1 + 2 \times R2)$
0	0	Off [ High impedance output]	Off

application.2 : One port H/Z/L control)

Logic control P1	Situation of Loading channel	Output voltage swing
5v	Forward rotation	$V_o = 2.5[V] \times \frac{8 \times R2}{(R1/2) + R2 + R3}$
Z (Hi impedance)	Short brake --> Stop	$V_o = 0 [V]$
0	Reverse rotation	$V_o = - 2.5[V] \times \frac{8 \times R2}{(R1/2) + R2 + R3}$

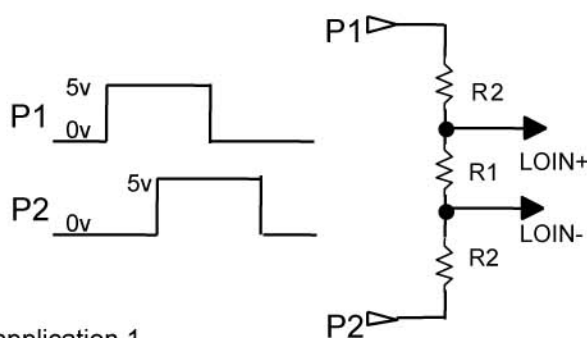

application.1  
( Two port H/L control )

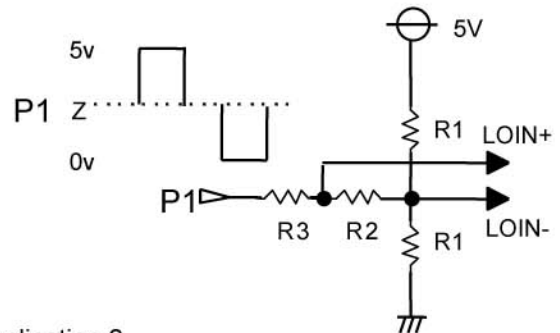

application.2  
(One port H/Z/L control)

# M63016FP

## Spindle Motor AND 4CH ACTUATOR Drive IC

### Spindle channel

The relationship between the differential voltage between Spin and REF and the torque is shown in right Figure. The voltage gain[Gvo] is 1.0[V/V]. The current gain[Gio] is 20A/V (at sensing resistor : 0.5 ohm, and R1=∞, R2=0ohm) in forward torque directions, and the dead zone is from 0mV to 80mV (at R1= ∞, R2=0ohm)

The coil current gain under the reverse torque is the same with IN forward torque directions. And the limitation function gets on when the differential voltage of VM1(12V) ~ RSP is 0.5V at forward and 0.3V at reverse in case of SELECT6, SELECT7, SELECT8 the differential voltage of VM1 (12V) ~ RSP is 0.3V at forward. Therefore, this mode is available in order to reduce a temperature under acceleration.

Therefore current-gain-control and current-limit of this IC is determined with sensing resistor value, and more detail control can be determined with setting a gain-resistor outer this IC as below.

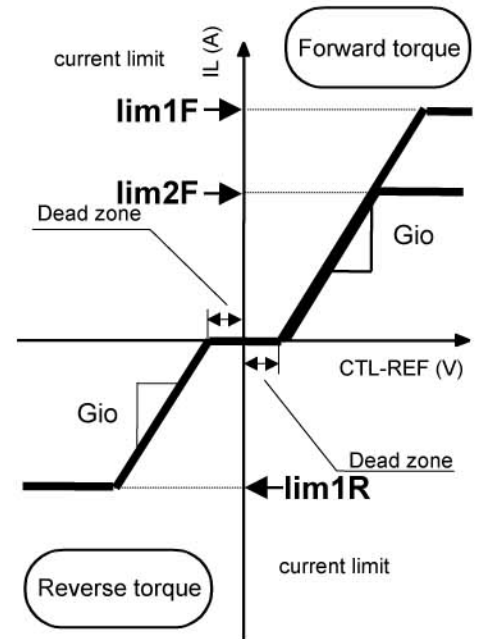

For obtaining the above mentioned characteristic, it is necessary to set the REF input voltage range as 1.0-3.3V(5VCC=5V conditions).

However, if 5VCC condition limit minimum value(5VCC=4.5V conditions) it is necessary to set the REF input voltage range as 1.0V-2.8V.

The example of current-gain and current-limit of Spindle.

RS [ohm]	Ilim1F [A]	Ilim2F [A]	Ilim1R [A]	Gio* [A/V]		
				R1= ∞ R2=0 ohm	R1=R2	R1=2XR2
0.50	1.00	0.68	0.68	2.00	1.00	0.66
0.75	0.66	0.45	0.45	1.33	0.66	0.44
1.00	0.50	0.34	0.34	1.00	0.50	0.33

$$Gio^* = R1 / [(R1+R2)XR_s] \text{ [A/V]}$$

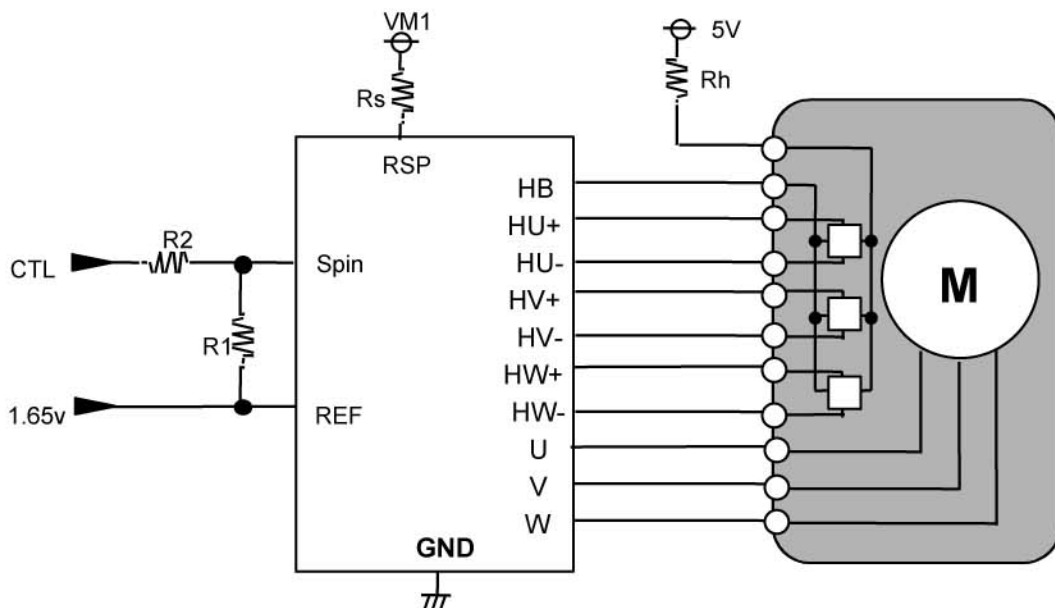

# M63016FP

## Spindle Motor AND 4CH ACTUATOR Drive IC

### Slide channel

The relationship between the differential voltage between SLIN and REF and the torque is shown in right Figure. The voltage gain[Gvo] is 1.0 [V/V]. The current gain is 20A/V (at sensing resistor : 0.5 ohm and R1=R2) in forward torque directions, and the dead zone is from 0mV to 60mV (at R1=R2=16kohm).

The coil current gain under the reverse torque is the same with in forward torque directions. And the limitation function gets on when the differential voltage of VM23(12V)~ RSL is 0.5V. Therefore current-gain-control and current-limit of this IC is determined with sensing resistor value. IN the input part, built-IN an inverted amplifier. It is possible to control more detail by setting external circuit.

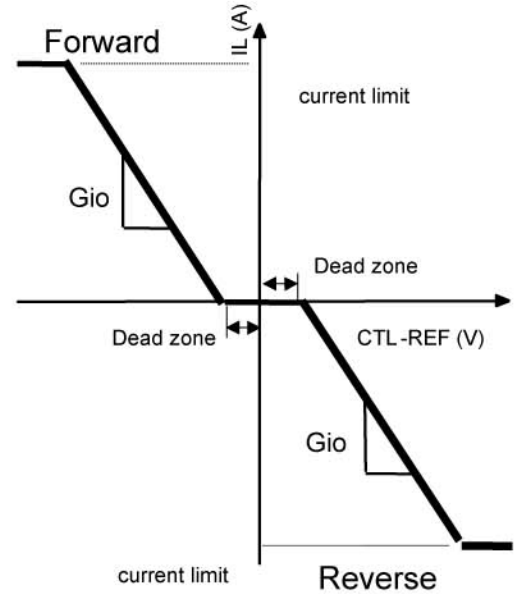

For obtaining the above mentioned characteristic, it is necessary to set the REF input voltage range as 1.0-3.3V(5VCC=5V conditions).

However, if 5VCC condition limit minimum value (5VCC=4.5V conditions), it is necessary to set the REF input voltage range as 1.0V-2.8V.

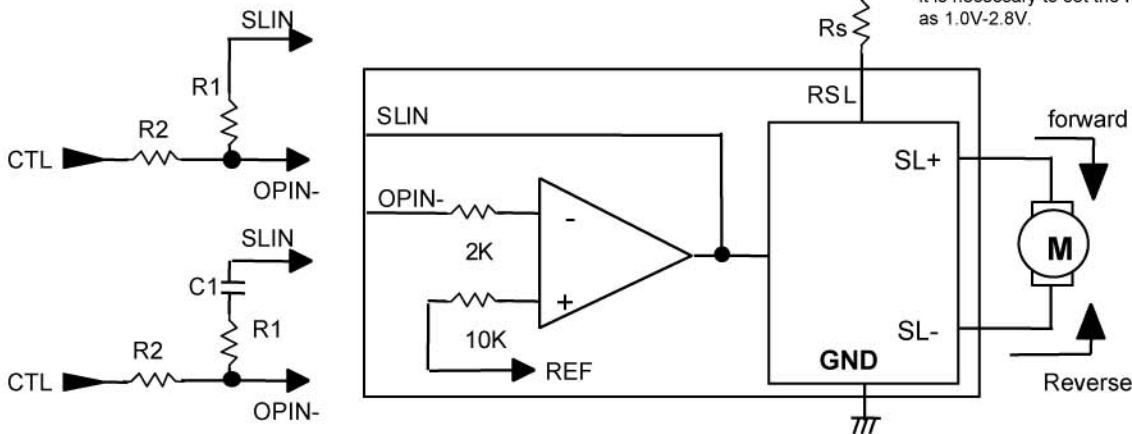

The example of current-gain and current-limit of Slide

RS [ohm]	Ilim [A]	Gio* [A/V]	
		R1=R2	2XR1=R2
0.50	1.00	2.00	1.00
0.75	0.66	1.33	0.66
1.00	0.50	1.00	0.50

$$Gio^* = R1 / R2 \times Rs \text{ [A/V]}$$

10K ohm are built in the non-inverted terminal of input amplifier, and 2K ohm are built in the inverted terminal. In order to compensate input offset, please set up external resistance so that synthetic resistance is set to 8K ohm.

# M63016FP

## Spindle Motor AND 4CH ACTUATOR Drive IC

### Focus / Tracking channel

The Focus and Tracking channel is the current feedback control drive of MITSUBISHI original. The Focus and Tracking is the same composition.

The relationship between the differential voltage between FOIN and REF and the output current is shown in right Figure.

The voltage gain is 0.4 [V/V] Therefore, the current gain is 0.8[A/V] in case of the sensing resistor is 0.5ohm.

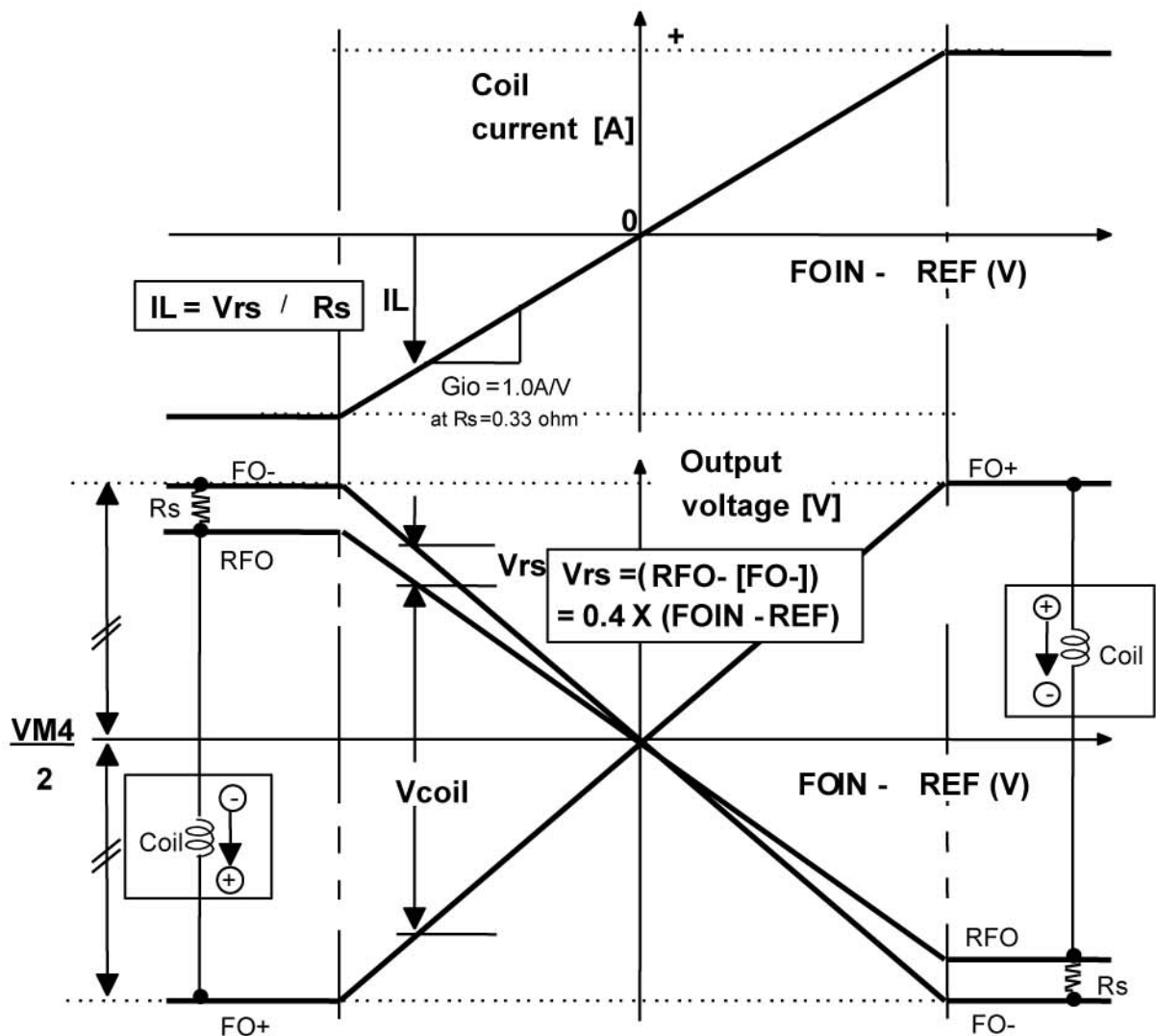
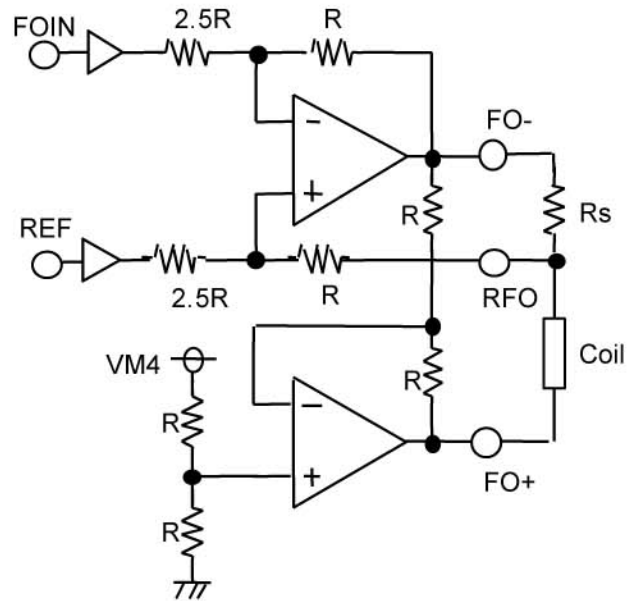

# M63016FP

## Spindle Motor AND 4CH ACTUATOR Drive IC

### Direct PWM operation

The spindle and the slide channel is controlled by the direct PWM control. Analog input voltage control the driving current which is in proportion to input voltage. This control is direct PWM control type of motor current chopper. Also, built-in the current limit circuit. This IC controls the motor current directly. direct PWM operation as follows;

- 1) The current which flows on a motor is detected, and current is supplied from a power supply until it reaches the predetermined instruction value to which the current is proportional to input voltage.
- 2) When current reaches an instruction value, an output transistor is changed and the period coil inertia energy to a career cycle is made to regeneration using an internal path.
- 3) After repeat 1) and 2).

Therefore, the IC constantly surveillance and control the current value itself use sensor resistor. Moreover, these ICs built-in current limit circuit so that protect to large current. Thus, if input excessive control voltage, the current don't flow that settle limit current.

FORWARD Current path timing 1.

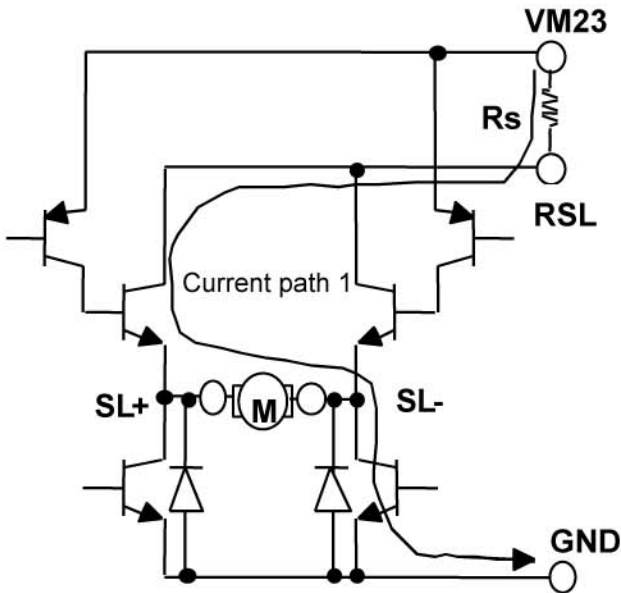

FORWARD Current path timing 2.

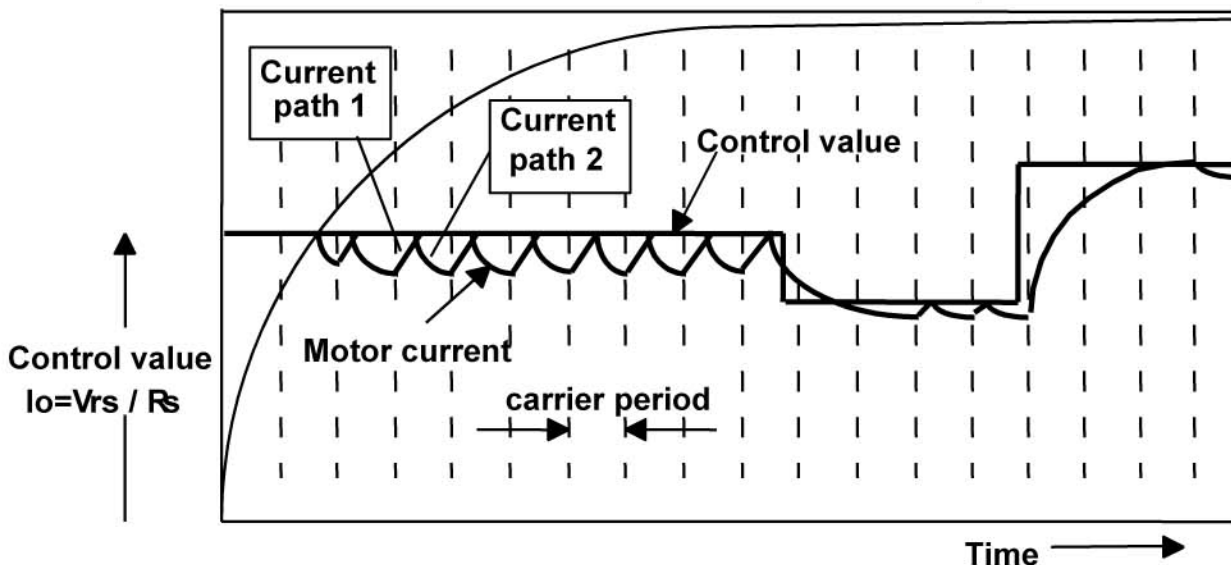
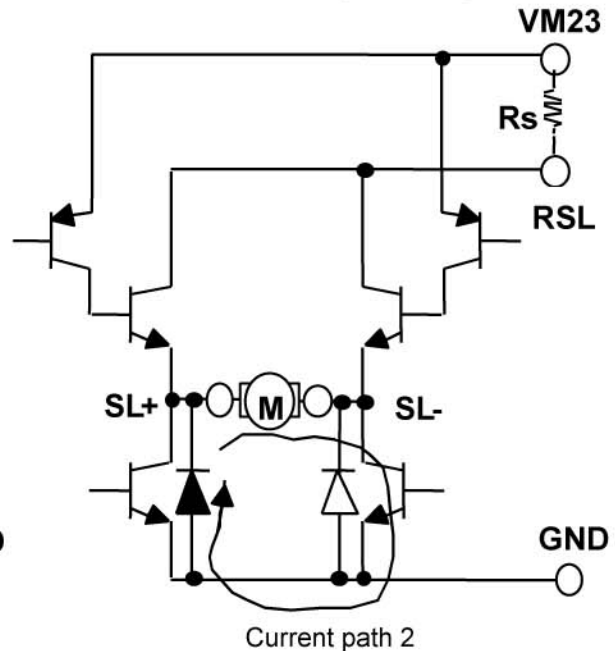

# M63016FP

## Spindle Motor AND 4CH ACTUATOR Drive IC

### PWM carrier frequency setting

PWM carrier frequency is decided by charging and discharging the capacitor that is connected to OSC terminal outer IC. Examination of the relationship the capacitor connected to OSC terminal and PWM carrier frequency is given in following table.

Capacitor [pF]	330	220	180	130	110
Carrier Frequency [KHz]	<b>65</b>	<b>90</b>	<b>110</b>	<b>140</b>	<b>160</b>

\*note) This PWM carrier frequency is TYP value.

### Recommendation of SHORT BRAKE MODE at Spindle DRIVE

This IC has two brake mode, PWM-BRAKE-MODE and SHORT-BRAKE-MODE. IN this IC recommendation, SHORT-BRAKE-MODE is superior to PWM-BRAKE-MODE to reducing the power dissipation and to avoid breaking down of this IC.

(By excessive reverse torque current IN braking a Motor with PWM-BRAKE from high-speed-rotation with being excessive Back-EMF, this IC could be broken.)

### The relationship between hall-amplifier-input and output-current-commutation/FG output at Spindle DRIVE

The relationship between the hall elements, the Motor output current and FG output(18pulse/rotation) are shown in bellow Figure.

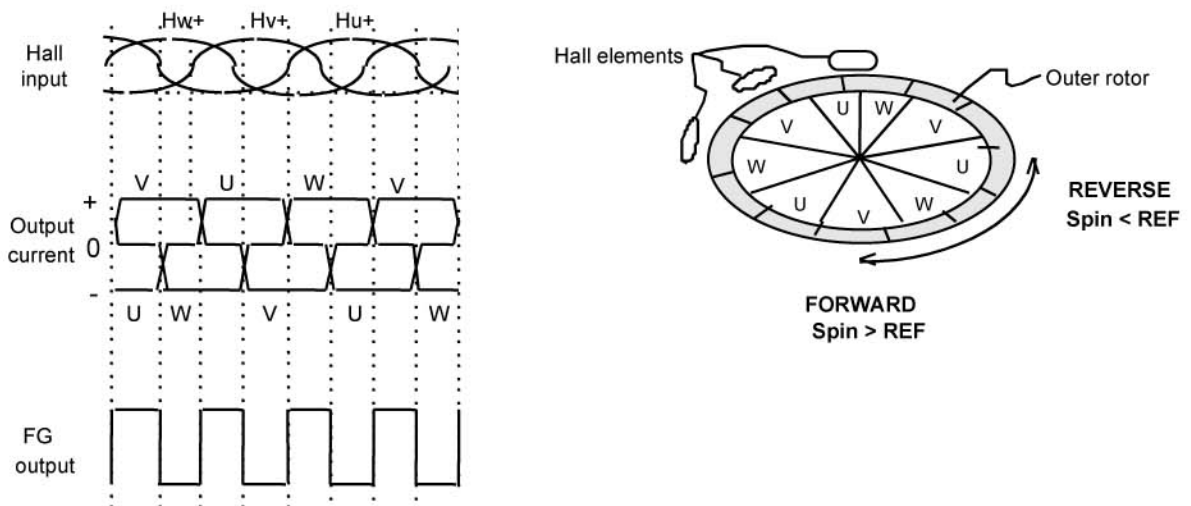

**FG function at Spindle DRIVE**

The FG terminal outputs the square pulse signal synchronizing with the Hall inputs [Hu+,Hu-, Hv+, Hv-,Hw+,Hw-] timing.And, the FG terminal is open-collector output.  
(cf.FG timing chart on the previous page)

**Phase delay circuit at Slide**

Phase delay circuit is built in the IC to detect an output spike current, when the Motor current direction is switching.  
IN switching the Motor current direction, Phase delay circuit switch-off all output transistor of H-bridge for 3usec.

**Output current setting at Slide**

IN this IC, since output transistor is NPN-type transistor, Motor coil current ( $I_o$ ) is larger than sensing resistance current about 20mA (TYP.) according to base current of output transistor. Therefore please design output current with consisting these base current.

# M63016FP

## Spindle Motor AND 4CH ACTUATOR Drive IC

[I/O circuit]

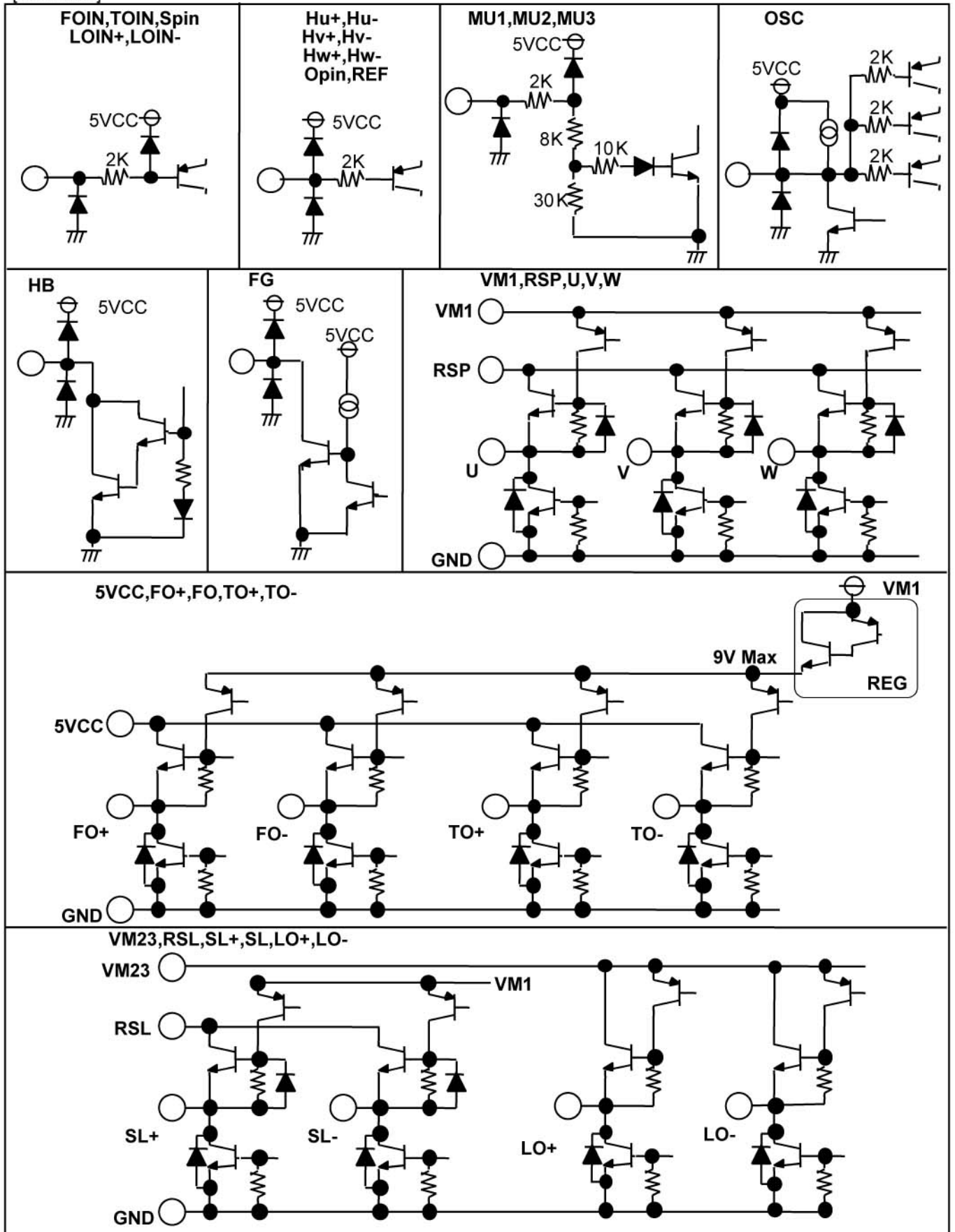



# M63016FP

## Spindle Motor AND 4CH ACTUATOR Drive IC

[The boards for thermal derating evaluation]

Board material  
 Glass-epoxy FR-4  
 Size  
 70X70mm  
 thickness  
 t=1.6mm  
 1 and 2 layers  
 material : copper  
 Thickness:t=18um

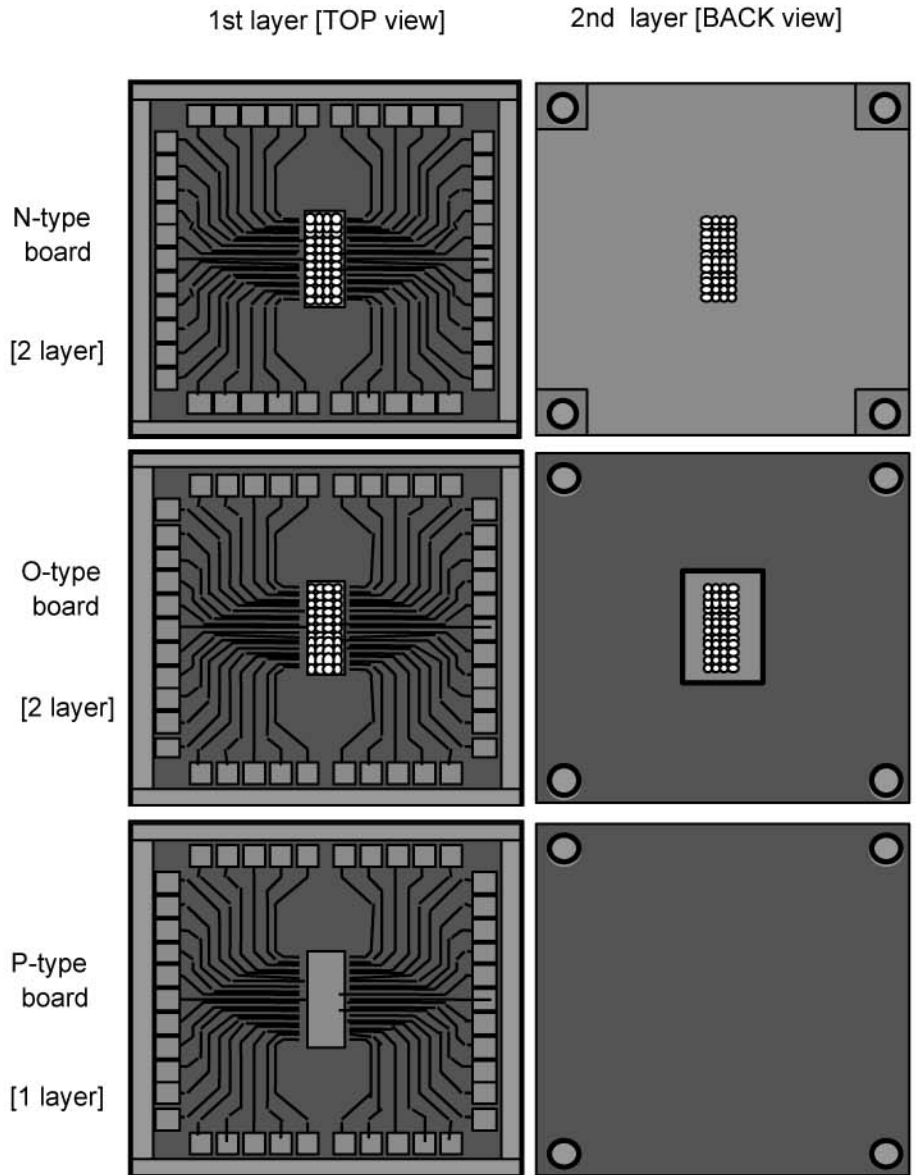
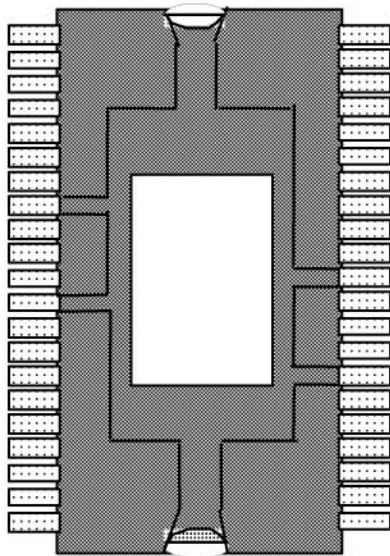

POWER-SSOP 42P9R-B

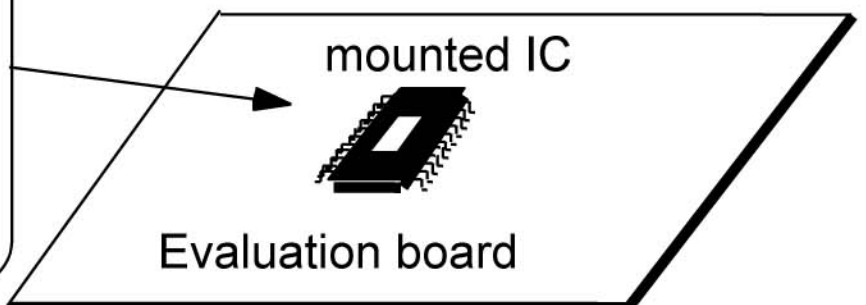
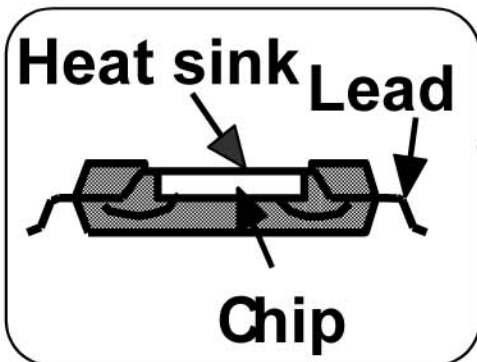

[The Notes on designing the layout of the board]

This IC has direct PWM controls for the Spindle channel and the Slide channel drive, therefore the circuits of the IC are influenced more easily by the PWM switching noise than those have linear controls. Please refer to the following notes on the occasion of designing the layout pattern of the board on which the IC is mounted.

**note1**

It is necessary for some application in order to reduce the PWM noise that pass condensers are connected between power supply pins(VM23:4pin, VM1:22pin, 5VCC:39pin) and GND pin, even if the power supplies of the application already have pass condensers. The closer the connection points of the condensers are to the pins, the more effective it is to reduce the noise.

Please refer to the values of the condensers on the page of [An example of the values of the external parts.] (The value of the condensers is only a reference value. It differs in each application because the bad influence of PWM noise relates to the layout pattern of the board.)

**note2**

The feedback point of the Spindle channel [the Slide channel] is the connected point to the VM1(22pin) [the VM23(4pin)] line from the RSP(15pin) [RSL(8pin)] pin through the sensing resistor RSP[RSL]. Therefore the closer the feedback point is to the power supply pin, the more stable the circuits are for the PWM noise. cf. [application circuit]

**note3**

The farther the large current output lines(especially PWM output lines of the Spindle CH. and the Slide CH.) which are indicated as wide lines in the Fig. [application circuit] are to the small signal input lines, the less the bad influence of the PWM noise comes to be without the cross-talk between a large current output line and a small input signal line.

[The Notes on designing the layout of the board]

**note4**

IN case the PWM switching noise influences the REF input, it is necessary for some application that a condenser is connected between REF pin(25pin) and GND pin. The closer the connection points of the condensers are to the pins, the more effective it is to reduce the noise. (This is the same as note1.)  
cf.[application circuit], [An example of the values of the external parts]

**note5**

The closer the GND side of the capacitor connected with OSC pin (30 pin) is to the GND pin(33pin), which is the nearest GND to the GND of the small signal circuit inside the IC, the less the bad influence of the PWM noise on the GND line comes to be.  
cf. [application circuit]

# M63016FP

## Spindle Motor AND 4CH ACTUATOR Drive IC

[APPLICATION CIRCUIT1]

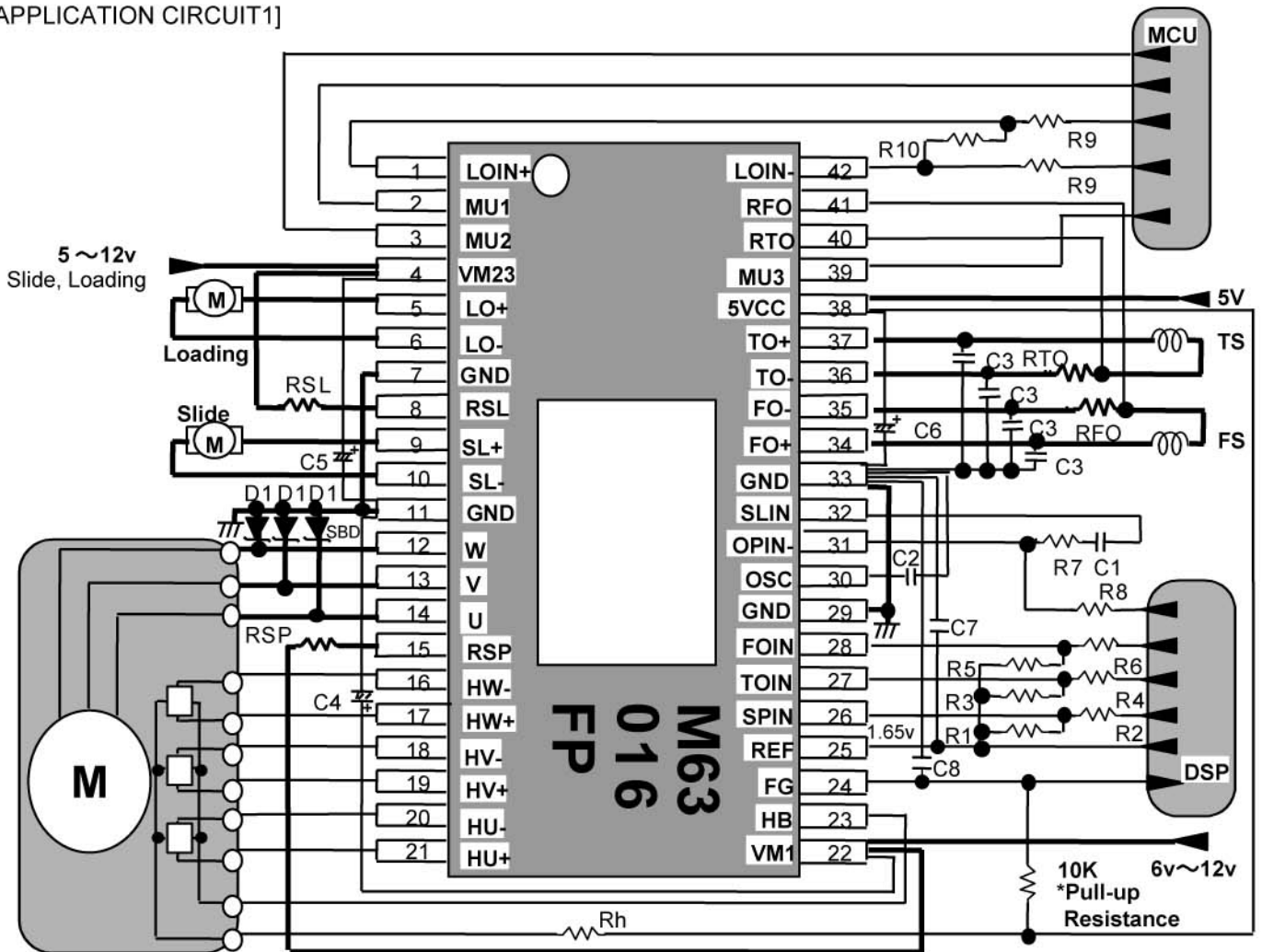

[An example of the values of the external parts]

\*These values are only examples, not the guaranteed values. And the values differ IN each application.

External Parts Name	Typ. value	Unit	Note
RSP	0.33	ohm	Ilim1F=1.5[A], Ilim1R=1.0[A], gain=3.0[A/V]
RSL	0.5	ohm	Ilim=1.0[A], gain=2.0[A/V]
RFO, RTO	0.33	ohm	gain=1.2[A/V]
Rh	200	ohm	
R1, R2, R3, R4, R5, R6	10	K ohm	
R7, R8	10	K ohm	
R9, R10	10	K ohm	
C1	330	pF	
C2	180	pF	FOSC=110KHz
C3	0.1 - 0.01	uF	Capacitors against output oscillation in a cold atmosphere (The capacitors are not necessary in some application.)
D1	-	-	Shottky Diode (VF<0.5V at IL=1.0A recommend) (The Shottky diodes are not necessary in some application. cf. note1,note2 in page(4/22))
C4, C5, C6	10 - 33	uF	Pass condenser for power supply
C7	0.1	uF	REF input noise filter condenser (The capacitor is not necessary in some application. )
C8	480	pF	FG output noise filter condenser

# M63016FP

## Spindle Motor AND 4CH ACTUATOR Drive IC

[APPLICATION CIRCUIT2] M63015FP same condition

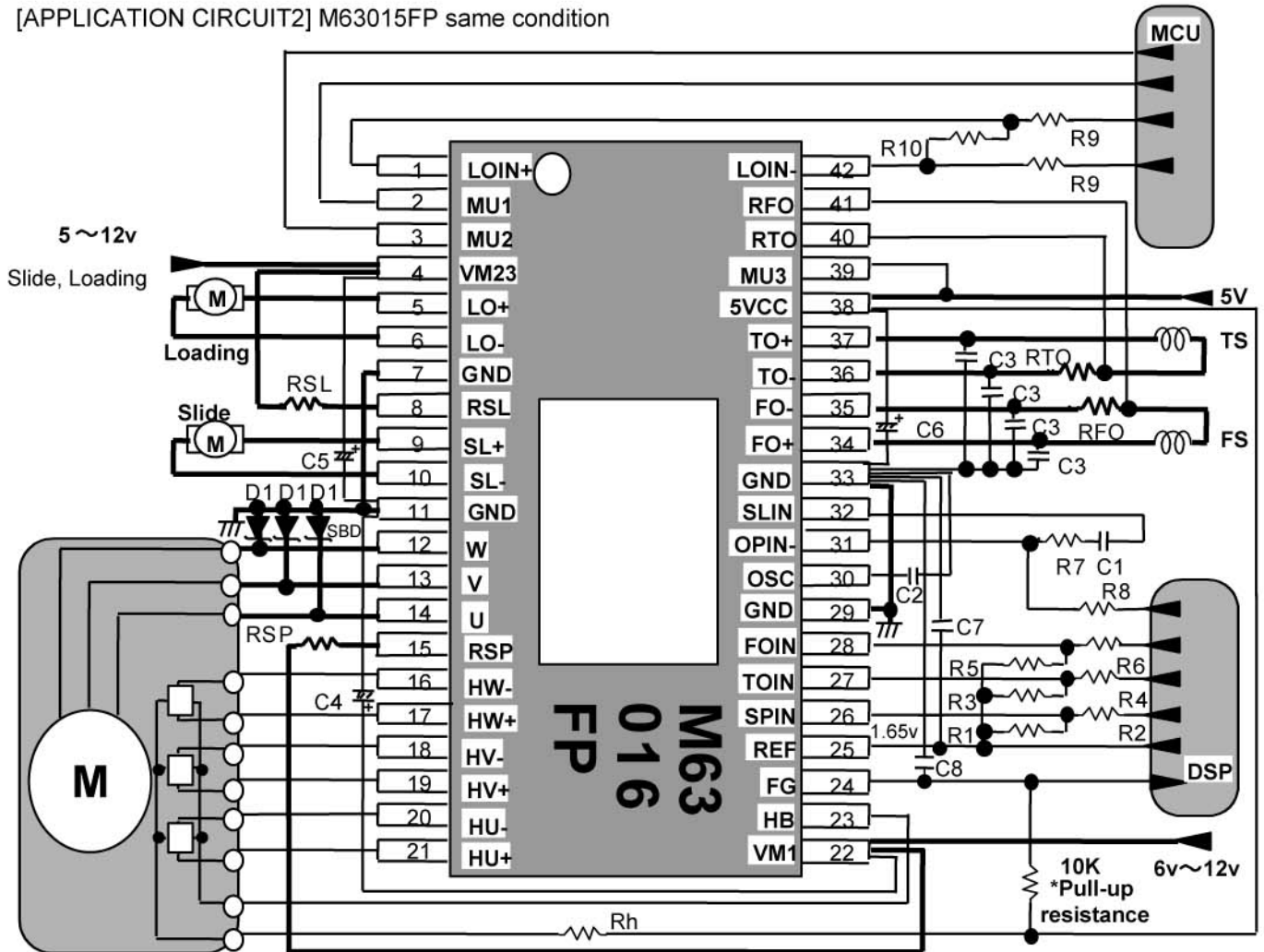

[An example of the values of the external parts]

\*These values are only examples, not the guaranteed values. And the values differ IN each application.

External Parts Name	Typ. value	Unit	Note
RSP	0.33	ohm	$I_{lim1F}=1.5[A]$ , $I_{lim1R}=1.0[A]$ , $gain=3.0[A/V]$
RSL	0.5	ohm	$I_{lim}=1.0[A]$ , $gain=2.0[A/V]$
RFO, RTO	0.33	ohm	$gain=1.2[A/V]$
Rh	200	ohm	
R1, R2, R3, R4, R5, R6	10	K ohm	
R7, R8	10	K ohm	
R9, R10	10	K ohm	
C1	330	pF	
C2	180	pF	$F_{osc}=110KHz$
C3	0.1 - 0.01	uF	Capacitors against output oscillation in a cold atmosphere (The capacitors are not necessary in some application.)
D1	-	-	Shottky Diode ( $V_F<0.5V$ at $I_L=1.0A$ recommend) (The Shottky diodes are not necessary in some application. cf. note1,note2 in page(3/20) )
C4, C5, C6	10 - 33	uF	Pass condenser for power supply
C7	0.1	uF	REF input noise filter condenser (The capacitor is not necessary in some application.)
C8	480	pF	FG output noise filter condenser