

**Silicon Double Balanced HMIC  
Mixer 1700 - 2300 MHz**

**MA4EX190H1-1225T  
V1**

**Features**

- Low Cost Miniature Plastic Package
- 6.6 dB Typical Conversion Loss at 1900 MHz
- 6.7 dB Typical Conversion Loss at 2200 MHz
- +13 to +17 dBm LO Drive
- HMIC™ Process
- Silicon High Barrier Schottky Diodes
- DC - 500 MHz IF Bandwidth
- **Lead Free ( RoHS Compliant ) With 260 °C. Reflow Capability**
- 100% MATTE Tin Plating

**Description and Applications**

M/A-COM's MA4EX190H1-1225T is a silicon monolithic 1700-2300 MHz double balanced mixer in a low cost miniature surface mount SOT-25 package. The die uses M/A-COM's unique HMIC™ silicon/glass process to achieve low loss passive elements while retaining the advantages of low barrier silicon Schottky diodes.

These mixers are well suited for high volume wireless and cellular applications where small size and repeatability are required. Typical applications include frequency conversion, modulation, and demodulation for receivers and transmitters in both portable cellular and base station applications.

**Absolute Maximum Ratings<sup>1</sup>**

Parameter	Maximum Ratings
Operating Temperature	-40 °C to +85 °C
Storage Temperature	-65 °C to +150 °C
Incident LO Power	+20 dBm
Incident RF Power	+20 dBm
Solder Temperature	+260 Deg C.

1. Exceeding these limits may cause permanent damage.

**SOT-25 Package Outline  
(Topview)**

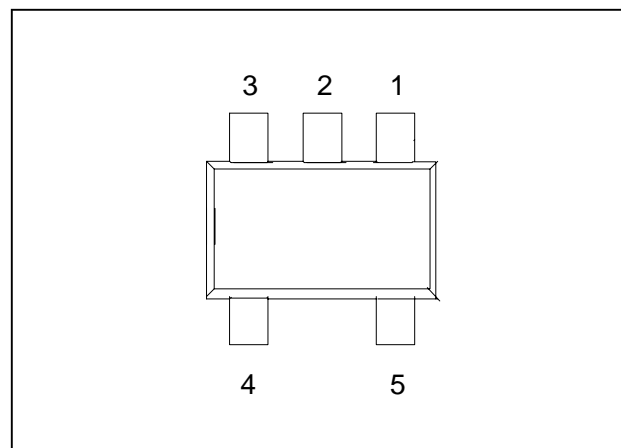

**PIN Configuration**

PIN	Function	PIN	Function
1	RF	4	GND
2	GND	5	IF
3	LO		

**Ordering Information**

Standard Part Number	Package
MA4EX190H1-1225T	Tape and Reel

**Schematic**

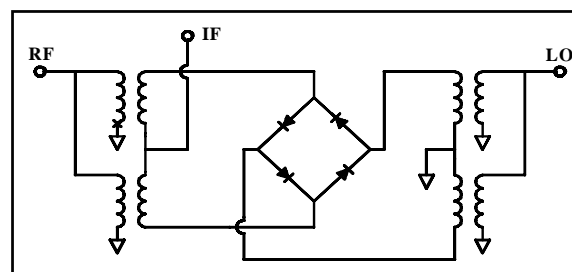

**Electrical Specifications @ +25 °C**

Parameter	Frequency Range	Test Conditions	Units	Min.	Typ.	Max.
Conversion Loss	1900 MHz 1700-2300 MHz	LO Drive = +15 dBm RF = -10 dBm, IF = 60 MHz	dB dB		6.6 6.7	7.0 8.0
L - R Isolation	1900 MHz 1700-2300 MHz	LO Drive = +15 dBm RF Level = -10 dBm	dB dB		30.0 30.0	
L - I Isolation	1900 MHz 1700-2300 MHz	LO Drive = +15 dBm RF Level = -10 dBm	dB dB		28.0 28.0	
R - I Isolation	1900 MHz 1700-2300 MHz	LO Drive = +15 dBm RF Level = -10 dBm	dB dB		23.0 20.0	
RF VSWR	1900 MHz 1700-2300 MHz	LO Drive = +15 dBm RF Level = -10 dBm			1.10:1 1.20:1	
IF VSWR	DC - 500 MHz	LO Drive = +15 dBm RF Level = -10 dBm			1.40:1	-
Input IP3	1900 MHz 1850-2300 MHz	LO Drive = +15 dBm IF = 60 MHz	dBm dBm	23 23	26.0 26.0	
Input 1 dB Compression	1900 MHz 1700-2300 MHz	LO Drive = +17 dBm IF = 60 MHz	dBm dBm		10.5 10.5	- -
IF 1 dB Bandwidth			MHz	0	500	-

**Typical Performance Curves (LO Drive = +15 dBm, RF = -10 dBm, IF = 60 MHz)**

**Conversion Loss**

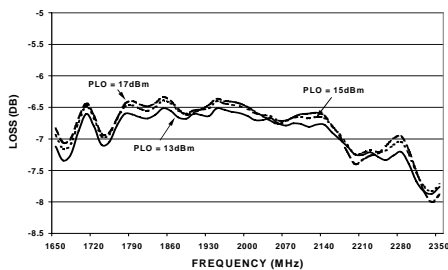

**Isolation**

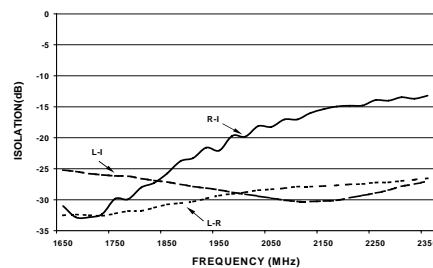

**VSWR**

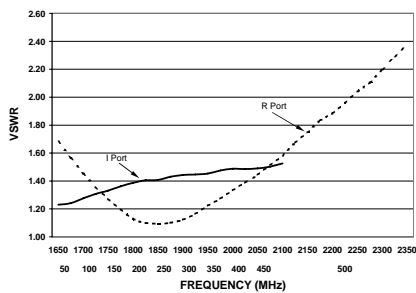

**Input IP3 & 1dB Compression Point**

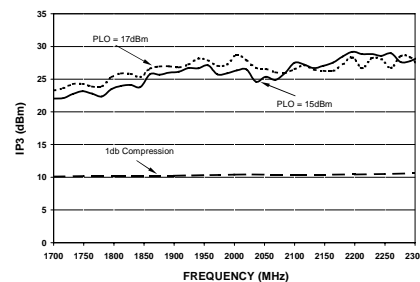

**Silicon Double Balanced HMIC  
Mixer 1700 - 2300 MHz**

**MA4EX190H1-1225T  
V1**

**Case Style - SOT-25**

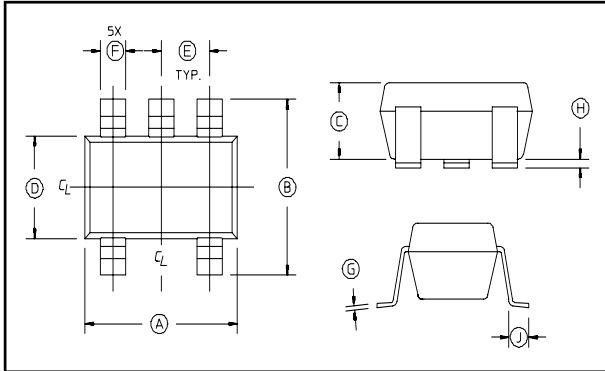

**SOT-25 Dimensions**

Dim	Inches		Millimeters	
	Min.	Max.	Min.	Max.
A	.106	.122	2.70	3.10
B	.100	.118	2.54	3.00
C	—	.051	—	1.30
D	.063 REF.		1.60 REF.	
E	.032	.043	.80	1.10
F	.014	.020	.35	.50
G	.003	—	.08	—
H	.000	.006	.00	.15
J	.018 REF.		.45 REF.	

Notes: 1. Leads Coplanarity should be 0.003 (0.08) max.