

**Digital Attenuator, 15 dB, 4-Bit  
DC - 2.0 GHz**

**MAATSS0015  
V3**

**Features**

- 1-dB Attenuation Steps to 15 dB
- High Accuracy
- Low Intermodulation Product: +50 dBm IP3
- Low DC Power Consumption: 50  $\mu$ W
- Tape and Reel Packaging Available
- Temperature Stability +/-0.15 dB: -40°C to +85°C
- Lead-Free SOIC-16 Package
- 100% Matte Tin Plating over Copper
- Halogen-Free "Green" Mold Compound
- 260°C Re-flow Compatible
- RoHS\* Compliant Version of AT-210

**Description**

M/A-COM's MAATSS0015 is a 4-bit, 1-dB step GaAs MMIC digital attenuator in a lead-free SOIC 16-lead surface mount plastic package. The MAATSS0015 is ideally suited for use where high accuracy, fast switching, very low power consumption and low intermodulation products are required. Typical applications include radio, cellular, and wireless LANs, GPS equipment and other gain/level control circuits.

The MAATSS0015 is fabricated with a monolithic GaAs MMIC using a mature 1-micron process. The process features full chip passivation for increased performance and reliability.

**Ordering Information<sup>1</sup>**

Part Number	Package
MAATSS0015	SOIC 16-Lead Plastic Package
MAATSS0015TR	Tape & Reel

1. Reference Application Note M513 for reel size information.

**Functional Schematic**

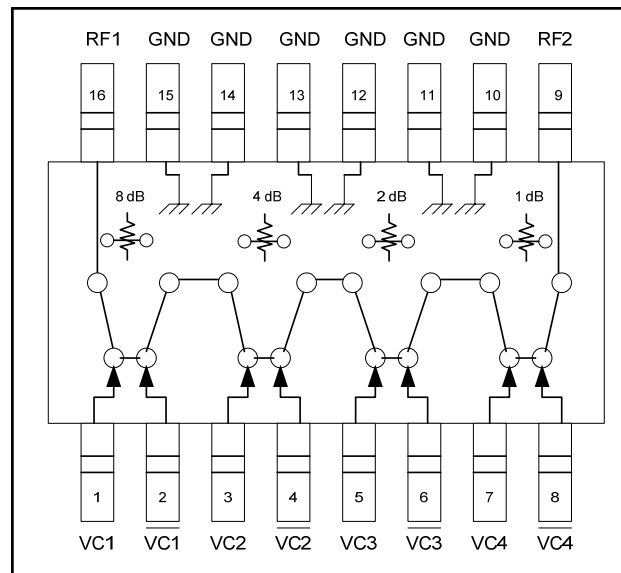

**Pin Configuration**

Pin No.	Function	Pin No.	Function
1	VC1	9	RF2
2	$\overline{\text{VC1}}$	10	GND
3	VC2	11	GND
4	$\overline{\text{VC2}}$	12	GND
5	VC3	13	GND
6	$\overline{\text{VC3}}$	14	GND
7	VC4	15	GND
8	$\overline{\text{VC4}}$	16	RF1

**Absolute Maximum Ratings<sup>2,3</sup>**

Parameter	Absolute Maximum
Input Power: 50 MHz 500-2000 MHz	+27 dBm +34 dBm
Control Voltage	-8.5 V $\leq$ V <sub>C</sub> $\leq$ 5V
Operating Temperature	-40°C to +85°C
Storage Temperature	-65°C to +150°C

2. Exceeding any one or combination of these limits may cause permanent damage to this device.
3. M/A-COM does not recommend sustained operation near these survivability limits.

**Digital Attenuator, 15 dB, 4-Bit  
DC - 2.0 GHz**

**MAATSS0015  
V3**

**Electrical Specifications:  $T_A = 25^\circ\text{C}$ ,  $V_C = 0\text{ V} / -5\text{ V}$ ,  $Z_0 = 50\ \Omega$**

Parameter	Test Conditions	Frequency	Units	Min.	Typ.	Max.
Insertion Loss (Reference state)		DC - 0.1 GHz	dB	—	0.9	—
		DC - 0.5 GHz	dB	—	1.3	1.5
		DC - 1.0 GHz	dB	—	1.5	1.8
		DC - 2.0 GHz	dB	—	2.0	—
Attenuation Accuracy <sup>4</sup>		DC - 1.0 GHz DC - 2.0 GHz		$\pm (0.15\text{ dB} + 3\% \text{ of Atten Setting in dB})\text{ dB}$ $\pm (0.30\text{ dB} + 3\% \text{ of Atten Setting in dB})\text{ dB}$		
VSWR			Ratio	—	1.4	—
Trise, Tfall	10% to 90% RF, 90% to 10% RF	—	nS	—	10	—
Ton, Toff	50% Control to 90% RF, 50% Control to 10% RF	—	nS	—	15	—
Transients	In-Band	—	mV	—	18	—
1 dB Compression	Input Power Input Power	0.05 GHz	dBm	—	22	—
		0.5 - 2.0 GHz	dBm	—	28	—
IP <sub>2</sub>	Measured Relative to Input Power (For two-tone input power up to +5 dBm)	0.05 GHz	dBm	—	49	—
		0.5 - 2.0 GHz	dBm	—	72	—
IP <sub>3</sub>	Measured Relative to Input Power (For two-tone input power up to +5 dBm)	0.05 GHz	dBm	—	45	—
		0.5 - 2.0 GHz	dBm	—	50	—
Control Current	$ V_C  = 5\text{ V}$		$\mu\text{A}$	—	10	20

4. Attenuation accuracy specifications apply with negative bias control and low inductance grounding.

**Lead-Free SOIC-16<sup>†</sup>**

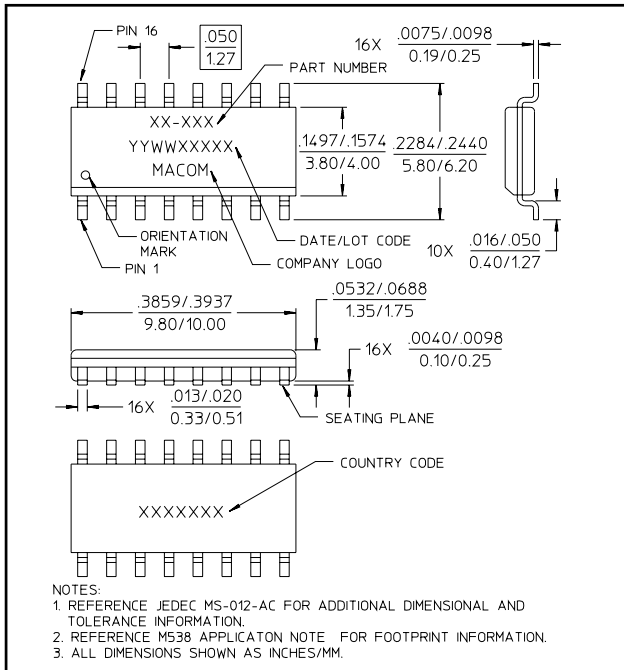

<sup>†</sup> Reference Application Note M538 for lead-free solder reflow recommendations.  
Meets JEDEC moisture sensitivity level 1 requirements

**Truth Table <sup>5</sup>**

Control Inputs								Attenuation (dB)
$\overline{VC4}$	VC4	$\overline{VC3}$	VC3	$\overline{VC2}$	VC2	$\overline{VC1}$	VC1	
1	0	1	0	1	0	1	0	Reference state
0	1	1	0	1	0	1	0	1 dB
1	0	0	1	1	0	1	0	2 dB
1	0	1	0	0	1	1	0	4 dB
1	0	1	0	1	0	0	1	8 dB
0	1	0	1	0	1	0	1	15 dB

5. 0 = -0.2 V to 0 V, 1 = -8 V to -5 V.

**Typical Performance Curves**

**Insertion Loss**

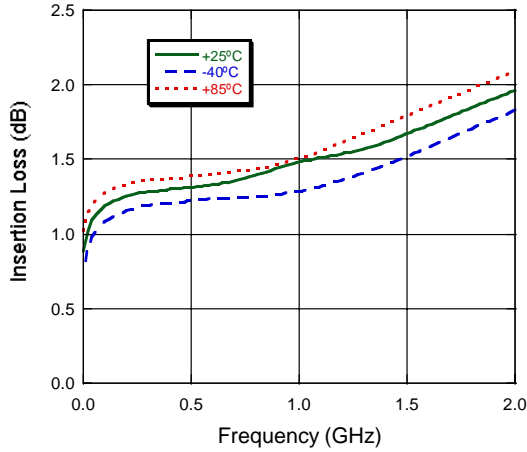

**Attenuation Accuracy**

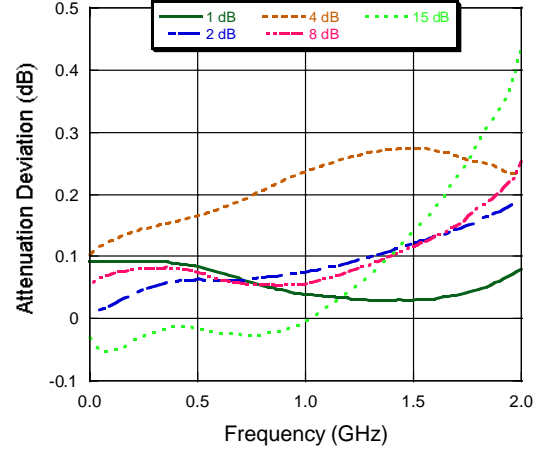

**VSWR**

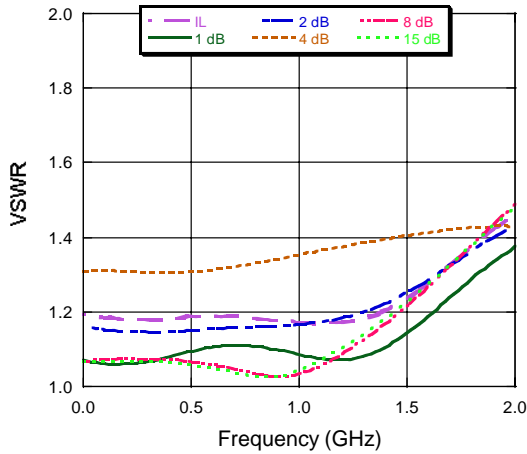

**Attenuation**

