

**GaAs SPDT Switch
DC - 3.0 GHz**

**MASWSS0151
V5**

Features

- Low Insertion Loss: 0.65 dB @ 2.4 GHz
- Isolation: 24 dB @ 2.4 GHz
- Low Current Consumption: <10 μ A @ -3 V
- Lead-Free SOT-363 Plastic Package
- 100% Matte Tin Plating over Copper
- Halogen-Free "Green" Mold Compound
- 260°C Reflow Compatible
- RoHS* Compliant Version of the SW-438

Description

M/A-COM's MASWSS0151 is a GaAs MMIC SPDT switch in a low cost, lead-free SC70 (SOT-363) surface mount plastic package. The MASWSS0151 is ideally suited for applications that include transmit / receive switching for Bluetooth and WLAN equipment.

The MASWSS0151 can also be used in applications up to 500 mW in cellular, PCS, DCS1800, GSM, CDMA, and other analog and digital wireless communications systems.

The MASWSS0151 is fabricated using a 0.5 micron gate length GaAs PHEMT process. The process features full passivation for performance and reliability.

Functional Schematic

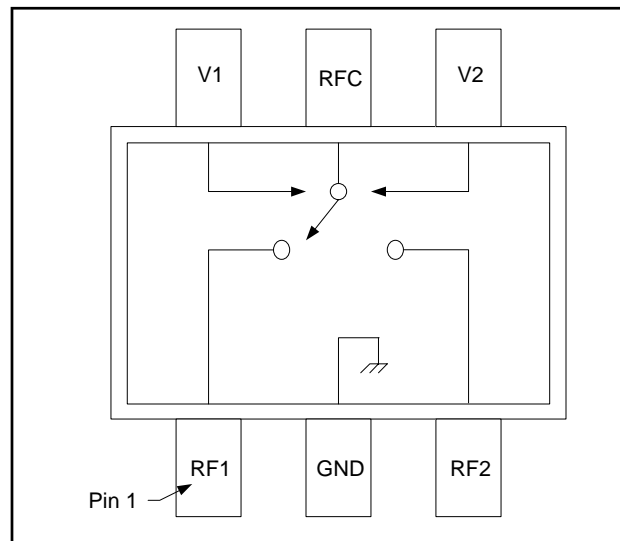

Pin Configuration

Pin No.	Function	Description
1	RF1	RF Input / Output
2	GND	RF Ground
3	RF2	RF Input / Output
4	V2	Control 2 Input
5	RFC	RF Common Input
6	V1	Control 1 Input

Ordering Information ¹

Part Number	Package
MASWSS0151	Bulk Packaging
MASWSS0151TR-3000	3000 piece reel
MASWSS0151SMB	Sample Board (Includes 5 Samples)

1. Reference Application Note M513 for reel size information.

Absolute Maximum Ratings ^{2,3}

Parameter	Absolute Maximum
Input Power (1 GHz)	+32 dBm
Operating Voltage	+8 Volts
Operating Temperature	-40°C to +85°C
Storage Temperature	-65°C to +150°C

2. Exceeding any one or combination of these limits may cause permanent damage to this device.
3. M/A-COM does not recommend sustained operation near these survivability limits.

* Restrictions on Hazardous Substances, European Union Directive 2002/95/EC.

**GaAs SPDT Switch
DC - 3.0 GHz**

**MASWSS0151
V5**

Electrical Specifications: $T_A = 25^\circ\text{C}$, $V_C = 0\text{ V} / -3.0\text{ V}$, $\text{Pin} = 0\text{ dBm}$, $Z_0 = 50\ \Omega$ ⁴

Parameter	Test Conditions	Units	Min.	Typ.	Max.
Insertion Loss	DC - 3.0 GHz	dB	—	0.65	0.8
Isolation	DC - 1.0 GHz	dB	29	31	—
	1.0 - 2.0 GHz	dB	—	25	—
	2.0 - 3.0 GHz	dB	—	21	—
Return Loss	DC - 1.5 GHz	dB	—	22	—
	1.5 - 3.0 GHz	dB	—	20	—
P1dB	1 GHz	dBm	—	31	—
IP2	Two Tone, 10 dBm / Tone, 900 MHz, 5 MHz Spacing	dBm	—	81	—
IP3	Two Tone, 10 dBm / Tone, 900 MHz, 5 MHz Spacing	dBm	—	55	—
2nd Harmonic	2.4 GHz, Pin = +20 dBm	dBc	—	-70	—
3rd Harmonic	2.4 GHz, Pin = +20 dBm	dBc	—	-60	—
Ton, Toff	50% control to 90% RF, 50% control to 10% RF	nS	—	20	—
Trise, Tfall	10% to 90% RF, 90% to 10% RF	nS	—	10	—
Control Current		μA	—	5	10

4. For positive voltage control, external DC blocking capacitors are required on all RF ports.

Truth Table^{5,6}

V1	V2	RFC-RF1	RFC-RF2
1	0	Off	On
0	1	On	Off

5. Differential voltage, V (state 1) - V (state 0), must be +2.1 V minimum and must not exceed 5 V.
 6. 0 = -5 V to 0 V, 1 = -2.9 V to 5 V.

Handling Procedures

Please observe the following precautions to avoid damage:

Static Sensitivity

Gallium Arsenide Integrated Circuits are sensitive to electrostatic discharge (ESD) and can be damaged by static electricity. Proper ESD control techniques should be used when handling these devices.

Lead-Free SC70 (SOT-363)[†]

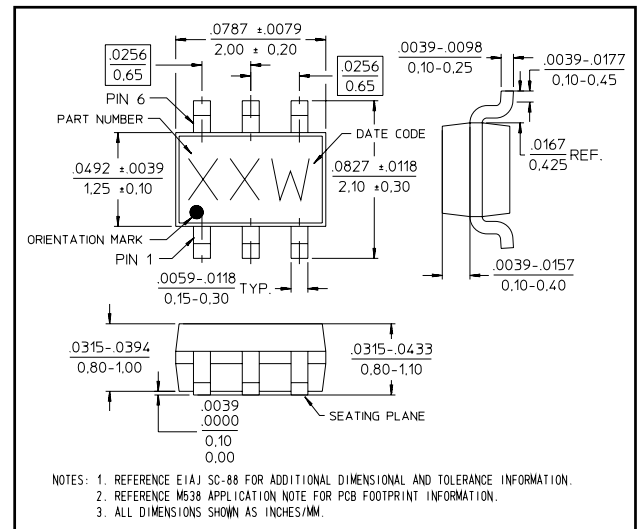

[†] Reference Application Note M538 for lead-free solder reflow recommendations.

Typical Performance Curves vs. Frequency over Temperature

Insertion Loss

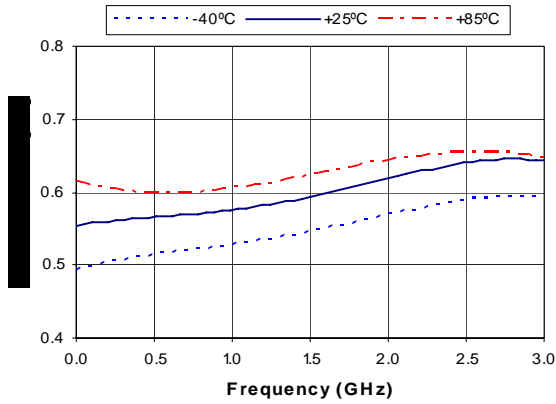

Isolation

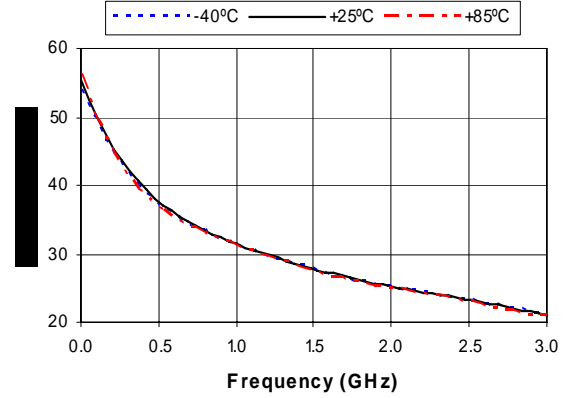

Return Loss

