

## ML34063 DC-to-DC Converter Control Circuit

### ❖ Application

- ◆ Battery Powered Equipment
- ◆ Palmtops
- ◆ Video Recorders

### ❖ Features

- Operating Voltage from 3V to 35V
- Low Standby Current
- Output Switch Current up to 1.5A
- Output Voltage Adjustable
- Operating Frequency at 100KHz
- 2% Accuracy Voltage Reference
- Package Available: PDIP-8 (1.25W) & SO-8 (625mW)

### ❖ General Description

The ML34063 is a DC/DC converter. It consists of an internal temperature compensated voltage reference, comparator, controlled duty cycle oscillator with an active current limit circuit, driver and high current output switch. It can be used in step-down, step-up and voltage-inverting applications with a minimum number of external components.

### ❖ Block Diagram

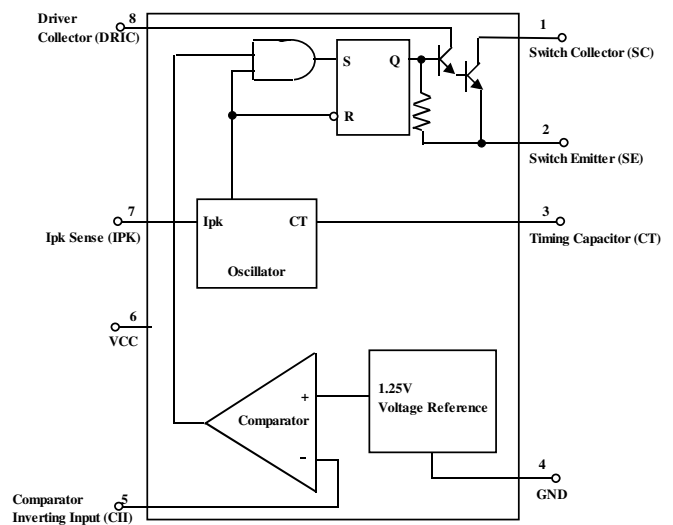

### ❖ Ordering Information

Part Number	Package
ML34063NG	PDIP-8 (PB Free)
ML34063MG	SO-8 (PB Free)
ML34063N	PDIP-8
ML34063M	SO-8

### ❖ Pin Configuration

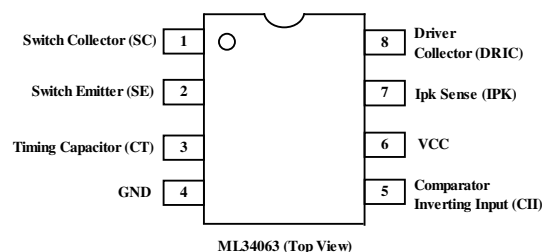

**❖ Absolute Maximum Ratings**

Parameter	Symbol	Ratings	Units
Input Voltage	V <sub>IN</sub>	35	V
Comparator Input Voltage Range	V <sub>IR</sub>	-0.3 to 35	V
Switch Collector Voltage	V <sub>C(Switch)</sub>	35	V
Switch Emitter Voltage (V <sub>Pin 1</sub> = 35V)	V <sub>E(Switch)</sub>	35	V
Switch Collector to Emitter Voltage	V <sub>CE(Switch)</sub>	35	V
Drive Collector Voltage	V <sub>C(Drive)</sub>	35	V
Switch Collector Current	I <sub>C(Switch)</sub>	100	mA
Switch Current	I <sub>SW</sub>	1.5	A
Power Dissipation at T <sub>A</sub> = 25 °C	PDIP-8	P <sub>d</sub>	mW
	SO-8		
Thermal Resistance	PDIP-8	R <sub>θJA</sub>	°C/W
	SO-8		
Operating Ambient Temperature	T <sub>opr</sub>	-0 ~ +70	°C
Storage Temperature	T <sub>stg</sub>	-65 ~ +150	°C

**❖ Electrical Characteristics (V<sub>CC</sub> = 5V, T<sub>A</sub> = 25°C, C<sub>T</sub> = 1nF, unless otherwise specified.)**
**Oscillator**

Parameter	Symbol	Conditions	Min	Typ	Max	Units
Frequency	f <sub>OSC</sub>	V <sub>Pin 5</sub> = 0V	24	33	42	kHz
Charge Current	I <sub>chg</sub>	V <sub>CC</sub> = 5.0V to 35V	24	35	42	uA
Discharge Current	I <sub>dichg</sub>	V <sub>CC</sub> = 5.0V to 35V	140	220	260	uA
Discharge to Charge Current Ratio	I <sub>dichg</sub> /I <sub>chg</sub>	Pin 7 to V <sub>CC</sub>	5.2	6.5	7.5	
Current Limit Sense Voltage	V <sub>pk(sense)</sub>	I <sub>chg</sub> = I <sub>dichg</sub>	250	300	350	mV

**Output Switch (Note1)**

Parameter	Symbol	Conditions	Min	Typ	Max	Units
Saturation Voltage, Darlington Connection	V <sub>CE(sat)</sub>	I <sub>SW</sub> = 1.0A, Pins 1, 8 connected		1.0	1.3	V
Saturation Voltage (Note 6)	V <sub>CE(sat)</sub>	I <sub>SW</sub> = 1.0A, R <sub>Pin 8</sub> = 82 ohm to V <sub>CC</sub> , Forced β = 20		0.45	0.7	V
DC Current Gain	h <sub>FE</sub>	I <sub>SW</sub> = 1.0A, V <sub>CE</sub> = 5.0V	50	75		
Collector Off-State Current	I <sub>C(off)</sub>	V <sub>CE</sub> = 35V		0.01	100	uA

**Comparator**

Parameter	Symbol	Conditions	Min	Typ	Max	Units
Threshold Voltage	V <sub>th</sub>		1.225	1.25	1.275	V

**Total Device**

Parameter	Symbol	Conditions	Min	Typ	Max	Units
Supply Current	I <sub>cc</sub>	V <sub>CC</sub> = 5.0V to 35V, Pin 7 = V <sub>CC</sub> , V <sub>Pin 5</sub> > V <sub>th</sub> , Pin 2 = GND, remaining pins open			4.0	mA

Note : 1. Low duty cycle pulse techniques are used during test to maintain junction temperature as close to ambient temperatures possible.

❖ *Step-Up Converter Application Circuit*

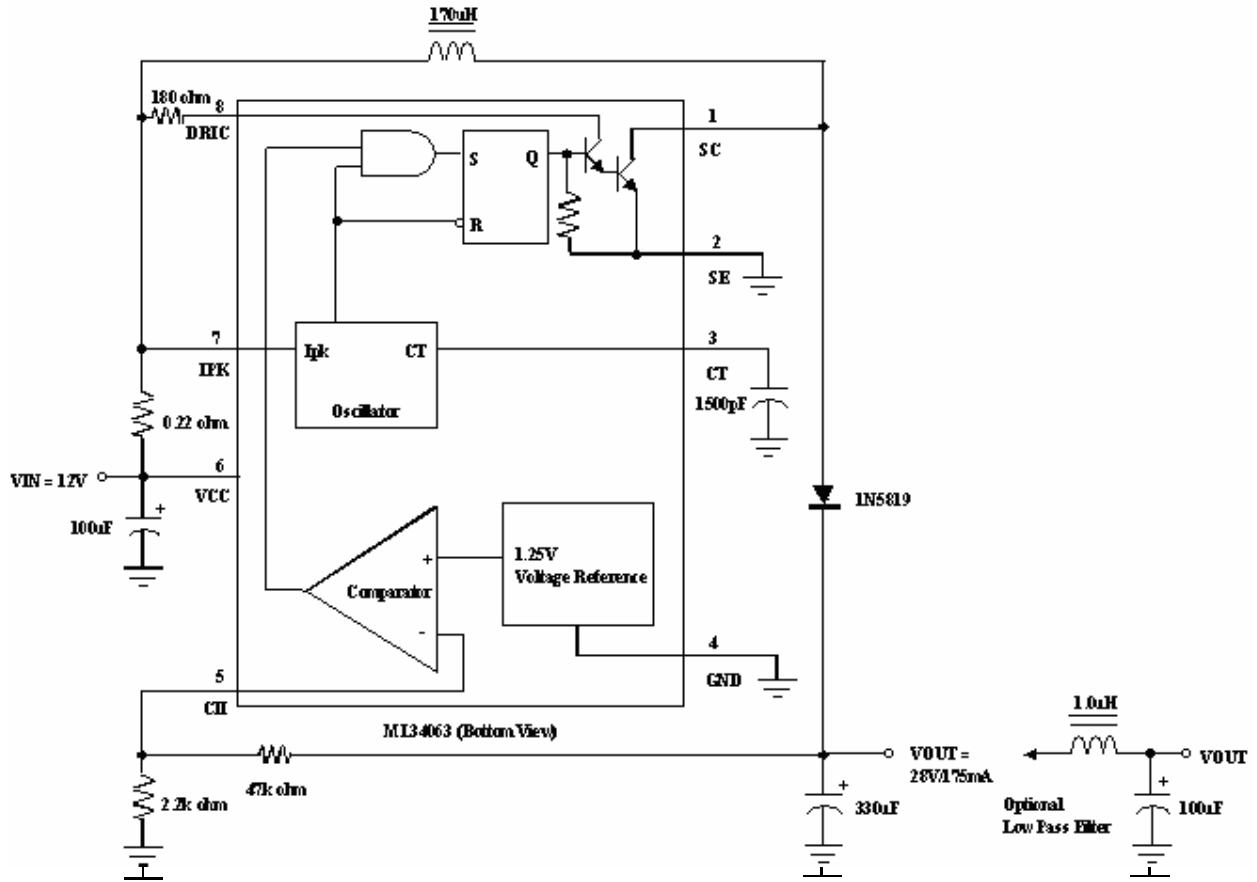

Test	Conditions	Results
Line Regulation	$V_{in} = 8.0V$ to $16V$ , $I_O = 175mA$	$30mV \pm 0.05\%$
Load Regulation	$V_{in} = 12V$ , $I_O = 75mA$ to $175mA$	$10mV \pm 0.017\%$
Output Ripple	$V_{in} = 12V$ , $I_O = 175mA$	$400 mV_{pp}$
Efficient	$V_{in} = 12V$ , $I_O = 175mA$	$87.7\%$
Output Ripple with Optional Filter	$V_{in} = 12V$ , $I_O = 175mA$	$40 mV_{pp}$

❖ *Step-Down Converter Application Circuit*

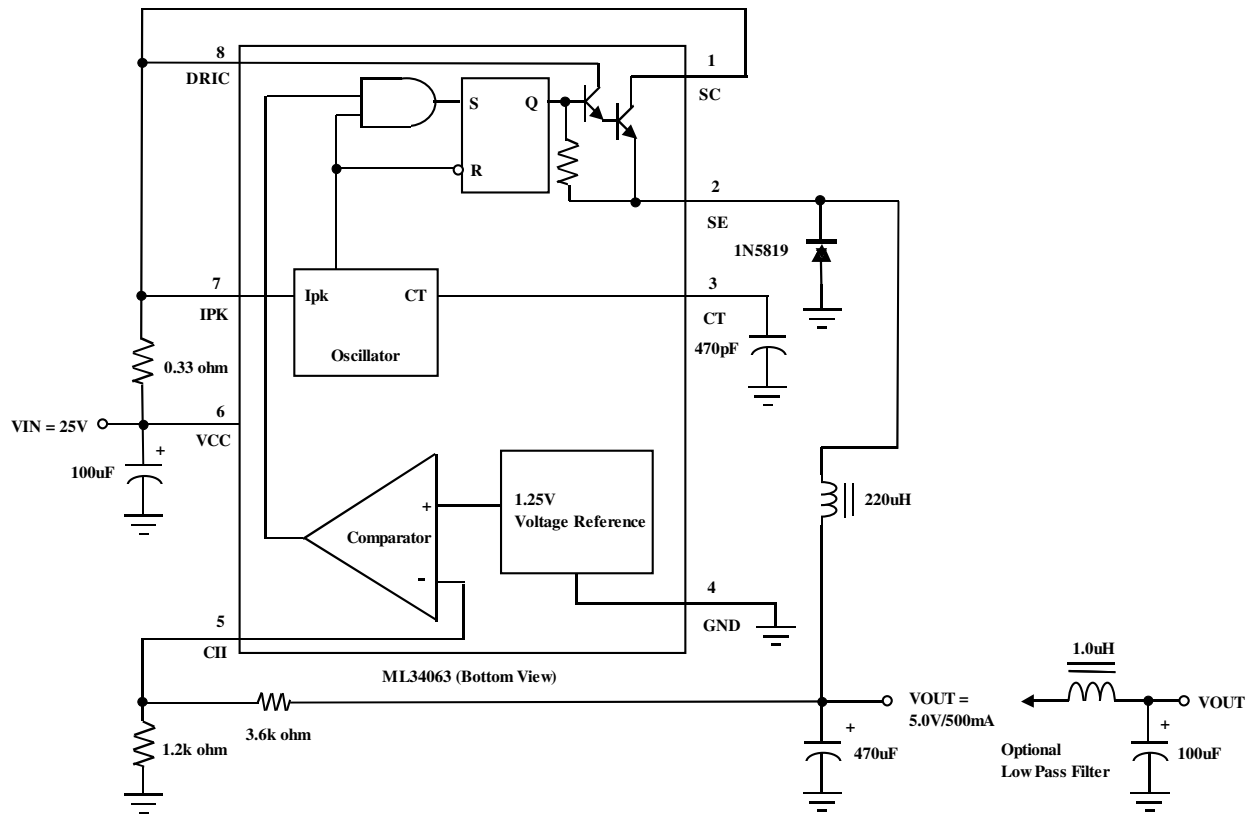

Test	Conditions	Results
Line Regulation	$V_{in} = 15V \text{ to } 25V, I_O = 500mA$	$12mV \pm 0.12\%$
Load Regulation	$V_{in} = 25V, I_O = 50mA \text{ to } 500mA$	$3.0mV \pm 0.03\%$
Output Ripple	$V_{in} = 25V, I_O = 500mA$	$120 \text{ mVpp}$
Short Circuit Current	$V_{in} = 25V, R_L = 0.1 \text{ ohm}$	1.1A
Efficient	$V_{in} = 25V, I_O = 500mA$	83.7%
Output Ripple with Optional Filter	$V_{in} = 25V, I_O = 500mA$	$40 \text{ mVpp}$

❖ *Voltage Inverting Converter Application Circuit*

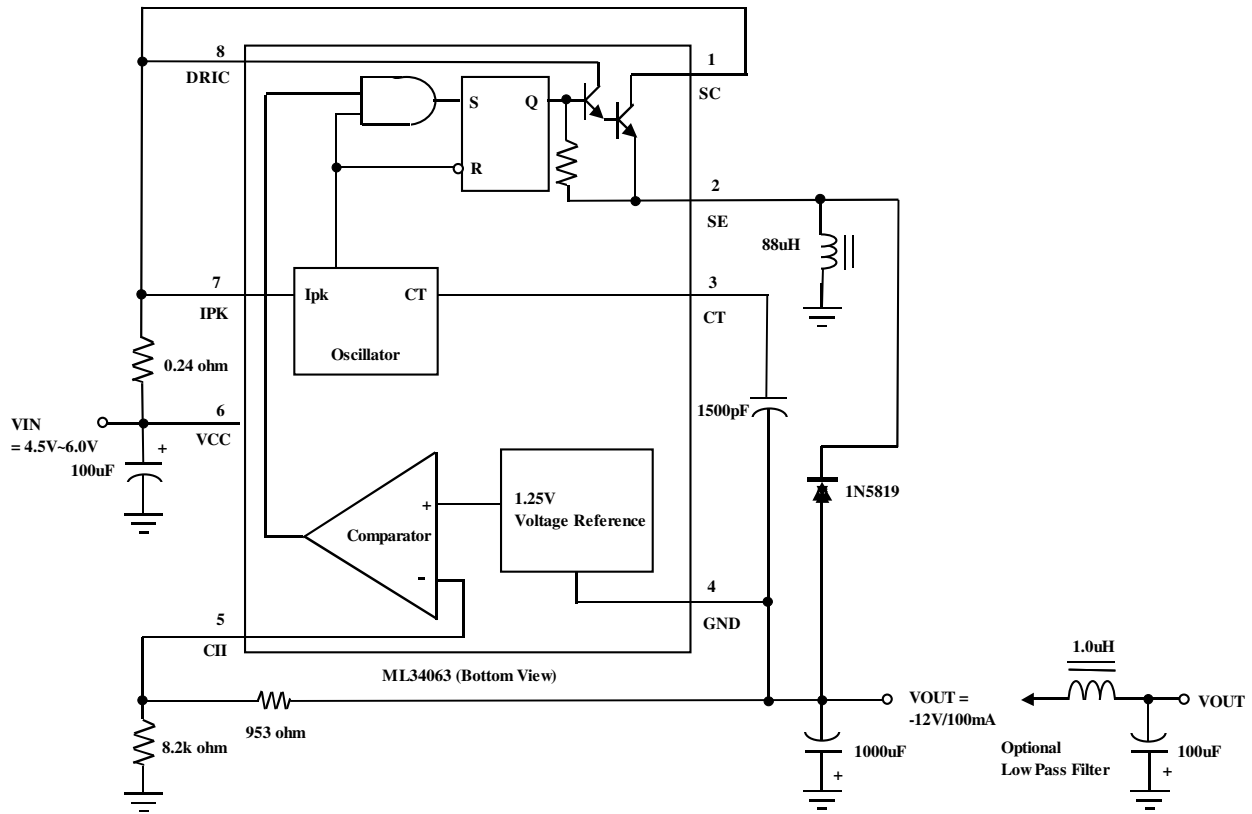

Test	Conditions	Results
Line Regulation	$V_{in} = 4.5V$ to $6.0V$ , $I_O = 100mA$	$3.0mV \pm 0.012\%$
Load Regulation	$V_{in} = 5.0V$ , $I_O = 10mA$ to $100mA$	$0.022V \pm 0.09\%$
Output Ripple	$V_{in} = 5.0V$ , $I_O = 100mA$	$500 mV_{pp}$
Short Circuit Current	$V_{in} = 5.0V$ , $R_L = 0.1 ohm$	$910 mA$
Efficient	$V_{in} = 5.0V$ , $I_O = 100mA$	$62.2\%$
Output Ripple with Optional Filter	$V_{in} = 5.0V$ , $I_O = 100mA$	$70 mV_{pp}$

The information presented in this document does not form part of any quotation or contract, is believed to be accurate and reliable and may be changed without notice. No liability will be accepted by the publisher for any consequence of its use.