

GENERAL DESCRIPTION

The ML9055A-02 is an LSI providing the bit map display on a dot matrix graphic LCD panel . With one chip, it is possible to construct a graphic display system with a maximum of 128 × 128 dots. Since all the functions necessary for driving the bit map type LCD panel are incorporated into a single chip, the ML9055A-02 allows to implement a dot matrix graphic LCD display system of bit map type with only a few chips in combination with an 8-bit microcomputer.

Using the CMOS process and a built-in RAM, the ML9055A-02 is highly suitable for displays in battery-operated portable equipment.

FEATURES

- Liquid Crystal Display (LCD) controller and driver
- Maximum display size: 128 columns × 128 rows
- Logic voltage: 1.8 to 3.0 V
- LCD drive voltage: 4.0 to 16.0 V
- Serial interface (3-line or 4-line, write only) and parallel interface
- Built-in voltage multiplier and oscillator circuit for display timing control
- LCD drive bias: 1/5 to 1/12
- Duty ratio: 1/16 to 1/128
- Voltage regulator temperature coefficient: -0.125%/°C
- Voltage multiplier: x3, x4, x5, x6
- Contrast adjustment: 64 levels available
- 4-level gray scale
- Partial display function
- Scroll function
- Frame frequency: 180 Hz
- Package: Gold bump chip, TCP

ML9055A-02DVWA (Gold bump chip name)

ML9055A-02DVVAZ01L (General TCP name)

BLOCK DIAGRAM

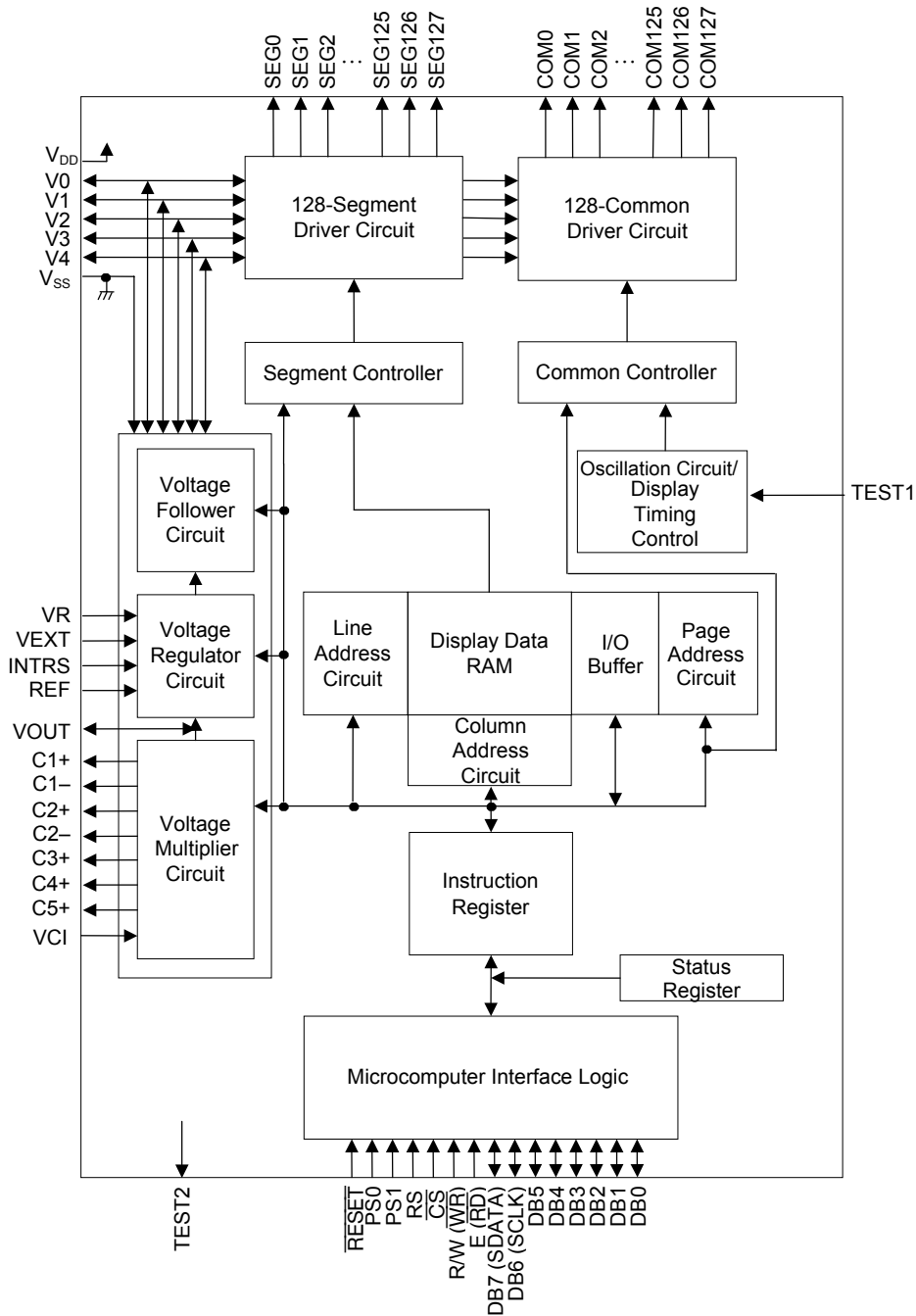

PIN CONFIGURATION (STANDARD TCP: BRONZE-FOIL FACE UP)

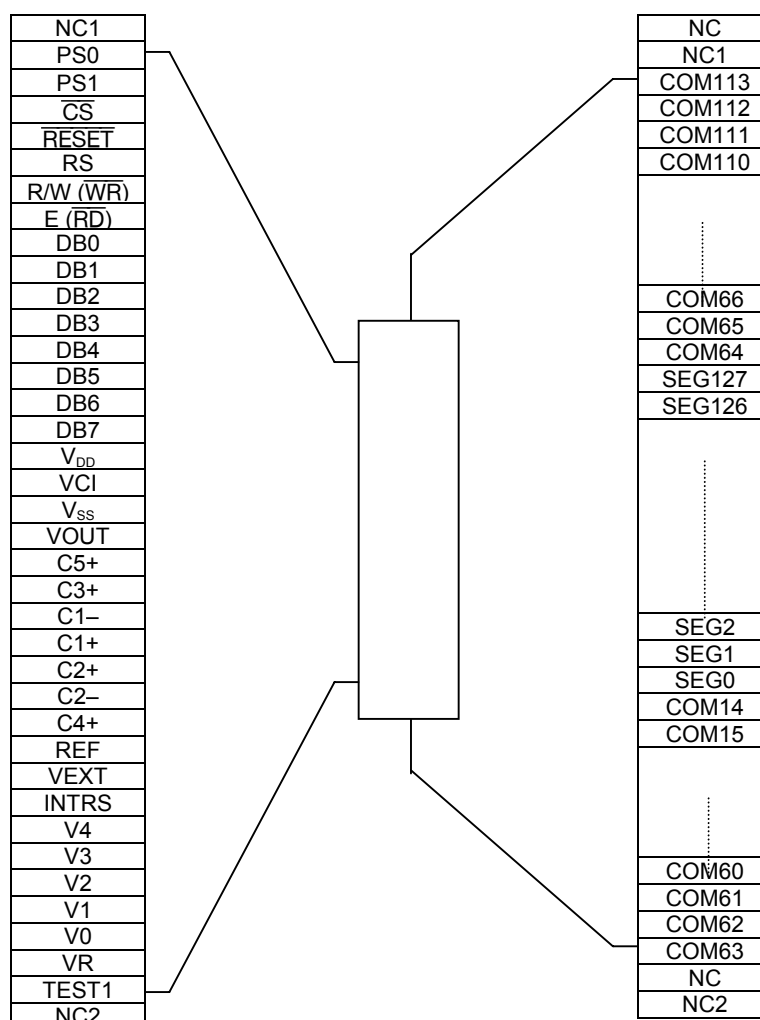

Note 1: This drawing is not a true external view of TCP, but it primarily shows the TCP pin layout.

Note 2: The TCP shown above is a standard TCP and does not have COM0 to COM13 pins and COM114 to COM127 pins. Also there is no TEST2 pin on the TCP.

(In the TCP, 128 lines from SEG0 to SEG127 and 100 lines from COM14 to COM113 are derived as the output pins.)

The external shape and the number of output pins of TCP can be customized as needed.

Note 3: Do not connect the NC pins to outside or any other pins. NC stands for "No Connection". The NC pins are not connected to the chip. All NC pins are independent.

NC1 remains connected to COM112 before dicing. Although the input side NC1 remains connected with the output side NC1 by dicing, the connection with COM112 is lost.

Similarly, NC2 remains connected to COM63 before dicing. Although the input side NC2 remains connected with the output side NC2 by dicing, the connection with COM63 is lost.

PIN DESCRIPTIONS

Function	Symbol	Type	Description
Power Supply	V _{DD}	Supply	Power supply
	V _{SS}	Supply	Ground
	V0	I/O	LCD drive power supply voltage pin V0, and LCD drive bias voltage pins V1 to V4
	V1		When applying the LCD drive power supply voltage and each LCD drive bias voltage from outside, notice to hold the following relationship:
	V2		$V_{SS} < V4 < V3 < V2 < V1 < V0$
	V3		The LCD drive bias voltages are generated when using the built-in voltage follower.
V4	For the value of each generated bias voltage, refer to the "Voltage Follower Circuit" section in this document.		
LCD Driver Supply	C1-	O	Connection pins of capacitors for multiplied voltage Connect capacitors for the voltage multiplier to these pins. (Connect pins with + sign to positive polarity of respective capacitors and pins with - sign to negative polarity of respective capacitors.) The connections of capacitors for multiplying voltage differ depending upon the voltage multiplication. The connections of the capacitors for multiplying voltage are described in the "Voltage Multiplier" section.
	C1+	O	
	C2-	O	
	C2+	O	
	C3+	O	
	C4+	O	
	C5+	O	
	VOUT	I/O	Voltage multiplier input/output pins When using an internal voltage multiplier, the following voltage is output from the VOUT pin: $V_{OUT} = V_{CI} \times \text{Voltage multiplication}$ When not using the internal voltage multiplier, input the external power supply voltage from this VOUT pin. About the pin processing in the case of an external input, refer to the "LCD Drive Power Supply Circuit" section.
	VCI	I	Multiplied voltage input pin of internal voltage multiplier When using an external power supply, tie this pin to V _{SS} .
	VR	I	V0 voltage adjustment pin (Adjusts V0 using external resistors.) When INTRS pin = "L", the V0 voltage is adjusted by connecting external resistors to this pin. The method of connecting external resistors is described in the "LCD Drive Power Supply Circuit" section. When INTRS pin = "H", keep this VR pin open. Note: When INTRS pin is "H", the internal resistors are selected for adjusting V0 and a very high internal resistor gets connected to VR pin. Therefore this ML9055A can be vulnerable to external noise. In designing the circuit board, pay proper attention to the external noise and leak.
REF	I	Internal/external reference voltage select pin. (L: External, H: Internal)	
VEXT	I	External reference voltage (V _{REF}) input pin. (Valid only when REF= L.) When using the internal reference power supply, keep this pin open.	
INTRS	I	V0 adjustment resistor select pin (L: External, H: Internal)	

Function	Symbol	Type	Description															
Microcomputer Interface	$\overline{\text{RESET}}$	I	Reset input pin (active "L")															
	PS0 PS1	I	Parallel/serial data setting (H = Parallel, L = Serial) <table border="1" data-bbox="710 497 1321 696"> <thead> <tr> <th>PS0</th> <th>PS1</th> <th>Interface</th> </tr> </thead> <tbody> <tr> <td>L</td> <td>L</td> <td>3-line serial interface</td> </tr> <tr> <td>L</td> <td>H</td> <td>4-line serial interface</td> </tr> <tr> <td>H</td> <td>L</td> <td>8080 parallel interface</td> </tr> <tr> <td>H</td> <td>H</td> <td>6800 parallel interface</td> </tr> </tbody> </table> <p>Note: When using the serial interface, leave D0-D5 open and connect E ($\overline{\text{RD}}$) and R/W ($\overline{\text{WR}}$) to V_{DD} or V_{SS}.</p>	PS0	PS1	Interface	L	L	3-line serial interface	L	H	4-line serial interface	H	L	8080 parallel interface	H	H	6800 parallel interface
	PS0	PS1	Interface															
	L	L	3-line serial interface															
	L	H	4-line serial interface															
	H	L	8080 parallel interface															
H	H	6800 parallel interface																
$\overline{\text{CS}}$	I	Chip select input pin (active "L")																
RS	I	Register select input pin Distinguishes between display data (H) and command data (L). Connect this pin to V_{DD} or V_{SS} for 3-line serial interface.																
R/W ($\overline{\text{WR}}$)	I	When connected to a 68-series MPU: Read/write execute control pin (H = read, L = write) When connected to an 80-series MPU: Write execute control pin (L = write)																
E ($\overline{\text{RD}}$)	I	When connected to a 68-series MPU: E clock input pin When connected to an 80-series MPU: Read execute control pin (L = read)																
LCD Driver	DB0 to DB7	I/O	When parallel interface is selected, 8-bit data bus pin When serial interface is selected, DB0 to DB5: Open DB6(SCLK): Serial clock input DB7(SDATA): Serial data input															
	SEG0 to SEG127	O	LCD segment driver outputs															
Test	COM0 to COM127	O	LCD common driver outputs															
	TEST1	I	Test pin of this LSI. Connect this pin to V_{DD} .															
	TEST2	O	Test pin of this LSI. Leave this pin open															

ABSOLUTE MAXIMUM RATINGS(V_{SS} = 0 V)

Parameter	Symbol	Condition	Rating	Unit
Power Supply Voltage	V _{DD}	T _j = 25°C	-0.3 to +4.0	V
Voltage Multiplier Input Voltage	V _{CI}	T _j = 25°C	-0.3 to +4.0 (*1)	V
Voltage Multiplier Output Voltage	V _{OUT}	T _j = 25°C	-0.3 to +20.0	V
LCD Drive Voltage	V ₀	T _j = 25°C	-0.3 to +20.0 (*2)	V
LCD Drive Bias Voltage	V _m (*3)	T _j = 25°C	-0.3 to V ₀ +0.3 (*4)	V
Logic Input Voltage	V _I	T _j = 25°C	-0.3 to V _{DD} +0.3	V
Storage Temperature Range	T _{stg}	Chip	-55 to +150	°C

*1. Notice that voltage multiplier output voltage V_{OUT} should not exceed 20 V.

*2. V₀ should not exceed V_{OUT}.

*3. V_m indicates V₁, V₂, V₃ and V₄.

*4. Notice that V_m should not exceed 20 V.

RECOMMENDED OPERATING CONDITIONS(V_{SS} = 0 V)

Parameter	Symbol	Condition	Range	Unit
Power Supply Voltage	V _{DD}	—	1.8 to 3.0	V
Voltage Multiplier Input Voltage	V _{CI}	—	V _{DD} to 3.0 (*1)	V
Voltage Multiplier Output Voltage	V _{OUT}	—	5.4 to 16.0	V
LCD Driver voltage	V ₀	—	4.0 to V _{OUT} -1	V
LCD Driver Bias Voltage 1	V ₁	—	3.2 to 14.7 (*2)	V
LCD Driver Bias Voltage 2	V ₂	—	2.4 to 13.4 (*2)	V
LCD Driver Bias Voltage 3	V ₃	—	1.6 to 2.7 (*2)	V
LCD Driver Bias Voltage 4	V ₄	—	0.8 to 1.4 (*2)	V
External Reference Voltage	V _{EXT}	—	1.8 to V _{DD}	V
Operating Temperature	T _{top}	Chip	-40 to +85	°C

*1. Notice that the voltage multiplier output voltage V_{OUT} is 16 V or below.

*2. Notice that V_{OUT}>V₀>V₁>V₂>V₃>V₄.

Do not expose the ML9055A to light when in use.

ELECTRICAL CHARACTERISTICS**DC Characteristics** $(V_{DD} = 1.8 \text{ to } 3.0 \text{ V}, V_{SS} = 0 \text{ V}, T_j = -40 \text{ to } +85^\circ\text{C})$

Parameter	Symbol	Condition	Min.	Typ.	Max.	Unit	Applied pins
High Input Voltage	V_{IH}	—	$0.8 \times V_{DD}$	—	V_{DD}	V	RESET, PS0, PS1, CS, RS, R/W (WR), E (RD), DB7 (SDATA), DB6 (SCLK), DB5–DB0, INTRs, REF
Low Input Voltage	V_{IL}	—	0.0	—	$0.2 \times V_{DD}$	V	
High Output Voltage	V_{OH}	$I_{OH} = -0.5 \text{ mA}$	$0.8 \times V_{DD}$	—	V_{DD}	V	DB7 (SDATA), DB6 (SCLK), DB5–DB0
Low Output Voltage	V_{OL}	$I_{OL} = 0.5 \text{ mA}$	0.0	—	$0.2 \times V_{DD}$	V	
Input Current	I_{IL}	$V_{IN} = V_{DD} \text{ or } V_{SS}$	-1.0	—	+1.0	μA	RESET, PS0, PS1, CS, RS, R/W (WR), E (RD), DB7 (SDATA), DB6 (SCLK), DB5–DB0, INTRs, REF
LCD Driver On Resistance	R_{ON}	$T_j = 25^\circ\text{C}$, 1/8 bias $V_0 = 8 \text{ V}$	—	2.5	5	$\text{k}\Omega$	SEG0–SEG127, COM0–COM127
Internal resistance ratio error	R_{ratio}	—	—	—	3	%	V0
VOUT-V0 Voltage	V_{OT0}	V0 load current = $300 \mu\text{A}$ VOUT = 8 V(applied externally) LCD output, no load	1	—	—	V	VOUT, V0

Parameter	Symbol	Condition	Min.	Typ.	Max.	Unit	Applied pins
Operating Current Consumption	I_{DD11}	Tj= 25°C, V _{DD} = V _{CI} = 2.75 V ×5 voltage multiplier 1/100 duty Frame frequency: 180 Hz Display: Off (*1)	—	150	230	μA	V _{DD} , V _{CI} (*2)
	I_{DD12}	Tj= 25°C, V _{DD} = V _{CI} = 2.75 V ×5 voltage multiplier 1/128 duty Frame frequency: 220 Hz Display: Off (*1)	—	185	285	μA	
	I_{DD21}	Tj= 25°C, V _{DD} = V _{CI} = 2.75 V ×5 voltage multiplier Display: On 1/100 duty Frame frequency: 180 Hz (Full checker board pattern (*1))	—	300	430	μA	
	I_{DD22}	Tj= 25°C, V _{DD} = V _{CI} = 2.75 V ×5 voltage multiplier Display: On 1/128 duty Frame frequency: 220 Hz (Full checker board pattern (*1))	—	370	530	μA	
Current Consumption in Power Save Mode	I_{SLEEP}	Power save mode Tj = 25°C, V _{DD} = 3.0 V	—	—	2	μA	
Voltage Multiplier Efficiency	E_{VC}	×3/×4/×5/×6 Using internal power supply No load	95	99	—	%	V _{OUT}
Reference Voltage	V_{REF}	Tj = -20°C	—	2.22	—	V	VEXT (*3)
		Tj = 25°C	2.04	2.10	2.16	V	
		Tj = 70°C	—	1.98	—	V	

(*1) No CPU access state.

No LCD panel load.

Other conditions: 1/12 bias; contrast = 60; internal resistance ratio setting = 5.8; 3-FRC; 9-level PWM; frame inversion

(*2) The current consumption is a sum of V_{DD} current and V_{CI} current.

(*3) V_{ref} voltage is measurable in the test mode, but cannot be measured when a customer is using the ML9055A in normal circumstances.

AC Characteristics

Serial Interface Timing

 $(V_{DD} = 1.8 \text{ V}, T_j = -40 \text{ to } +85^\circ\text{C})$

Parameter	Symbol	Min.	Typ.	Max.	Unit
Serial Clock Frequency	f_{CLK}	—	—	9	MHz
Serial Clock Cycle Time	t_{CLK}	111	—	—	ns
Serial Clock "H" Pulse Width	t_{WHS}	50	—	—	ns
Serial Clock "L" Pulse Width	t_{WLS}	50	—	—	ns
Data Setup Time	t_{DS}	50	—	—	ns
Data Hold Time	t_{DH}	50	—	—	ns
Chip Select Setup Time	t_{CSS}	60	—	—	ns
Chip Select Hold Time	t_{CSH}	50	—	—	ns
Chip Select "H" Pulse Width	t_{CH}	50	—	—	ns
Register Select Setup Time(*1)	t_{RSS}	60	—	—	ns
Register Select Hold Time(*1)	t_{RSH}	60	—	—	ns
Input Signal Rise Time (*2)	t_r	—	—	15	ns
Input Signal Fall Time (*2)	t_f	—	—	15	ns

(Note) (*1) Not applied to 3-line serial interface.

(*2) Applied to all input pins.

 $(V_{DD} = 2.7 \text{ V}, T_j = -40 \text{ to } +85^\circ\text{C})$

Parameter	Symbol	Min.	Typ.	Max.	Unit
Serial Clock Frequency	f_{CLK}	—	—	17	MHz
Serial Clock Cycle Time	t_{CLK}	58.8	—	—	ns
Serial Clock "H" Pulse Width	t_{WHS}	25	—	—	ns
Serial Clock "L" Pulse Width	t_{WLS}	25	—	—	ns
Data Setup Time	t_{DS}	25	—	—	ns
Data Hold Time	t_{DH}	25	—	—	ns
Chip Select Setup Time	t_{CSS}	30	—	—	ns
Chip Select Hold Time	t_{CSH}	25	—	—	ns
Chip Select "H" Pulse Width	t_{CH}	30	—	—	ns
Register Select Setup Time(*1)	t_{RSS}	30	—	—	ns
Register Select Hold Time(*1)	t_{RSH}	30	—	—	ns
Input Signal Rise Time (*2)	t_r	—	—	15	ns
Input Signal Fall Time (*2)	t_f	—	—	15	ns

(Note) (*1) Not applied to 3-line serial interface.

(*2) Applied to all input pins.

Parallel Interface Timing (68-series MPU)

(V_{DD} = 1.8 V, T_J = -40 to +85°C)

Parameter	Symbol	Condition	Min.	Typ.	Max.	Unit
Address Setup Time	t _{AS}	—	0	—	—	ns
Address Hold Time	t _{AH}	—	0	—	—	ns
$\overline{\text{CS}}$ "L" Pulse Width for Write	t _{CSL}	—	60	—	—	ns
$\overline{\text{CS}}$ "H" Pulse Width for Write	t _{CSH}	—	60	—	—	ns
$\overline{\text{CS}}$ "L" Pulse Width for Read	t _{CSL}	—	100	—	—	ns
$\overline{\text{CS}}$ "H" Pulse Width for Read	t _{CSH}	—	100	—	—	ns
E "H" Pulse Width for Write	t _{EH}	—	60	—	—	ns
E "L" Pulse Width for Write	t _{EL}	—	60	—	—	ns
E "H" Pulse Width for Read	t _{EH}	—	100	—	—	ns
E "L" Pulse Width for Read	t _{EL}	—	100	—	—	ns
Data Setup Time	t _{DS}	—	40	—	—	ns
Data Hold Time during Write	t _{DH}	—	10	—	—	ns
Data Access Time	t _{ACC}	C _L = 100 pF	—	—	90	ns
Data Hold Time during Read	t _{OH}	—	10	—	90	ns
System Write Cycle Time	t _{CYC}	—	150	—	—	ns
System Read Cycle Time	t _{CYC}	—	330	—	—	ns
Input Signal Rise Time (*1)	t _r	—	—	—	15	ns
Input Signal Fall Time (*1)	t _f	—	—	—	15	ns

(Note) (*1) Applied to all input pins.

(V_{DD} = 2.7 V, T_J = -40 to +85°C)

Parameter	Symbol	Condition	Min.	Typ.	Max.	Unit
Address Setup Time	t _{AS}	—	0	—	—	ns
Address Hold Time	t _{AH}	—	0	—	—	ns
$\overline{\text{CS}}$ "L" Pulse Width for Write	t _{CSL}	—	40	—	—	ns
$\overline{\text{CS}}$ "H" Pulse Width for Write	t _{CSH}	—	40	—	—	ns
$\overline{\text{CS}}$ "L" Pulse Width for Read	t _{CSL}	—	60	—	—	ns
$\overline{\text{CS}}$ "H" Pulse Width for Read	t _{CSH}	—	60	—	—	ns
E "H" Pulse Width for Write	t _{EH}	—	40	—	—	ns
E "L" Pulse Width for Write	t _{EL}	—	40	—	—	ns
E "H" Pulse Width for Read	t _{EH}	—	60	—	—	ns
E "L" Pulse Width for Read	t _{EL}	—	60	—	—	ns
Data Setup Time	t _{DS}	—	30	—	—	ns
Data Hold Time during Write	t _{DH}	—	5	—	—	ns
Data Access Time	t _{ACC}	C _L = 100 pF	—	—	50	ns
Data Hold Time during Read	t _{OH}	—	10	—	50	ns
System Write Cycle Time	t _{CYC}	—	150	—	—	ns
System Read Cycle Time	t _{CYC}	—	166	—	—	ns
Input Signal Rise Time (*1)	t _r	—	—	—	15	ns
Input Signal Fall Time (*1)	t _f	—	—	—	15	ns

(Note) (*1) Applied to all input pins.

Parallel Interface Timing (80-series MPU)

(V_{DD} = 1.8 V, T_j = -40 to +85°C)

Parameter	Symbol	Condition	Min.	Typ.	Max.	Unit
Address Setup Time	t _{AS}	—	0	—	—	ns
Address Hold Time	t _{AH}	—	0	—	—	ns
$\overline{\text{CS}}$, $\overline{\text{WR}}$ "L" Pulse Width for Write	t _{CSL}	—	60	—	—	ns
$\overline{\text{CS}}$, $\overline{\text{WR}}$ "H" Pulse Width for Write	t _{CSH}	—	60	—	—	ns
$\overline{\text{CS}}$, $\overline{\text{RD}}$ "L" Pulse Width for Read	t _{CSL}	—	100	—	—	ns
$\overline{\text{CS}}$, $\overline{\text{RD}}$ "H" Pulse Width for Read	t _{CSH}	—	100	—	—	ns
Data Setup Time	t _{DS}	—	40	—	—	ns
Data Hold Time during Write	t _{DH}	—	10	—	—	ns
Data Access Time	t _{ACC}	C _L = 100 pF	—	—	90	ns
Data Hold Time during Read	t _{OH}	—	10	—	90	ns
System Write Cycle Time	t _{CYC}	—	150	—	—	ns
System Read Cycle Time	t _{CYC}	—	330	—	—	ns
Input Signal Rise Time (*1)	t _r	—	—	—	15	ns
Input Signal Fall Time (*1)	t _f	—	—	—	15	ns

(Note) (*1) Applied to all input pins.

(V_{DD} = 2.7 V, T_j = -40 to +85°C)

Parameter	Symbol	Condition	Min.	Typ.	Max.	Unit
Address Setup Time	t _{AS}	—	0	—	—	ns
Address Hold Time	t _{AH}	—	0	—	—	ns
$\overline{\text{CS}}$, $\overline{\text{WR}}$ "L" Pulse Width for Write	t _{CSL}	—	40	—	—	ns
$\overline{\text{CS}}$, $\overline{\text{WR}}$ "H" Pulse Width for Write	t _{CSH}	—	40	—	—	ns
$\overline{\text{CS}}$, $\overline{\text{RD}}$ "L" Pulse Width for Read	t _{CSL}	—	60	—	—	ns
$\overline{\text{CS}}$, $\overline{\text{RD}}$ "H" Pulse Width for Read	t _{CSH}	—	60	—	—	ns
Data Setup Time	t _{DS}	—	30	—	—	ns
Data Hold Time during Write	t _{DH}	—	5	—	—	ns
Data Access Time	t _{ACC}	C _L = 100 pF	—	—	50	ns
Data Hold Time during Read	t _{OH}	—	10	—	50	ns
System Write Cycle Time	t _{CYC}	—	150	—	—	ns
System Read Cycle Time	t _{CYC}	—	166	—	—	ns
Input Signal Rise Time (*1)	t _r	—	—	—	15	ns
Input Signal Fall Time (*1)	t _f	—	—	—	15	ns

(Note) (*1) Applied to all input pins.

OSC Frequency

(V_{DD} = 1.8 to 3.0 V, T_j = 25°C)

Parameter	Symbol	Condition	Min.	Typ.	Max.	Unit
Frame Frequency	f _{FR}	9PWM, 1/100 duty	150	180	210	Hz
		9PWM, 1/128 duty	180	220	260	Hz

Reset Timing

(V_{DD} = 1.8 to 3.0 V, T_j = -40 to +85°C)

Parameter	Symbol	Condition	Min.	Typ.	Max.	Unit
Reset Pulse Width	t _{RES}	—	1.5	—	—	μs
Input Signal Rise Time	t _r	—	—	—	15	ns
Input Signal Fall Time	t _f	—	—	—	15	ns

TIMING DIAGRAMS

3- and 4-Line Serial Interface Timing Diagram

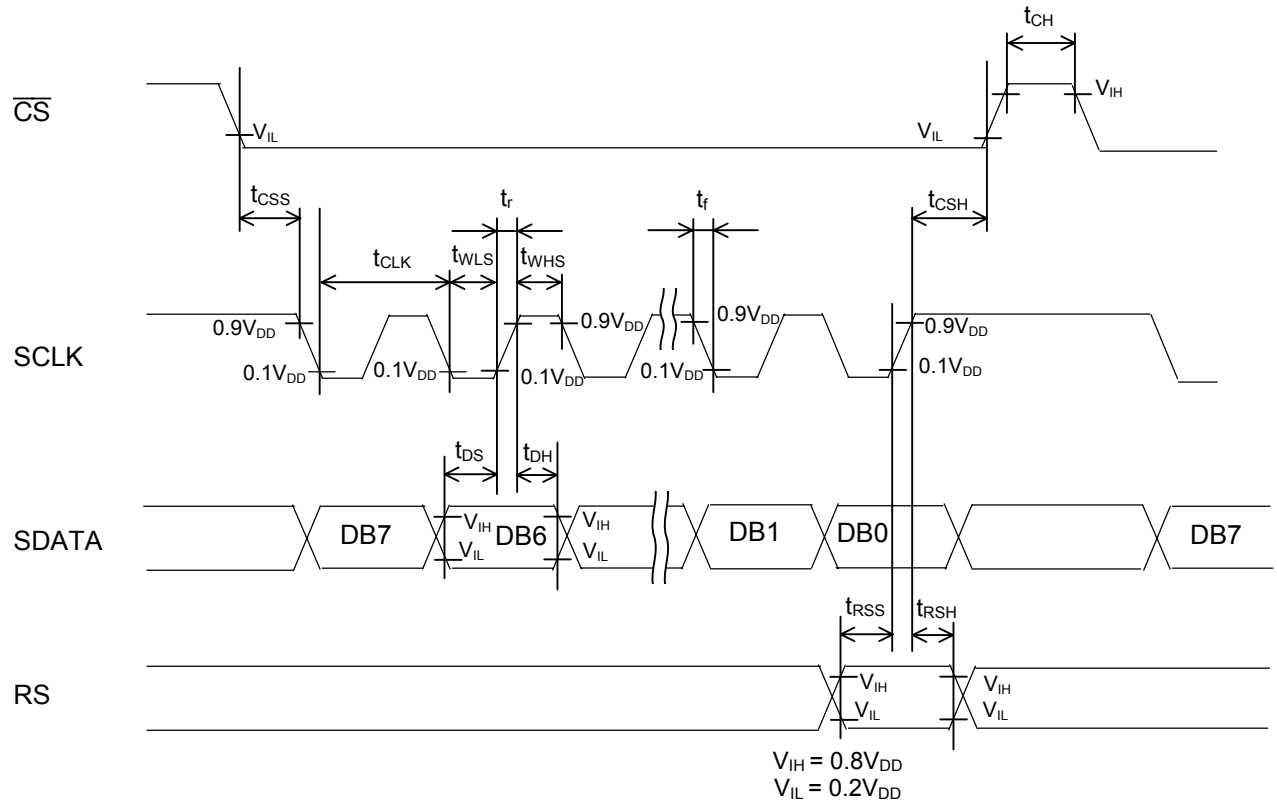

In 3-line system, the ML9055A interfaces with a microcomputer by 3 lines namely, \overline{CS} , SCLK, and SDATA.

The method to switch between the data and command in the 3-line system is described in the “Microcomputer Interface” section of Functional Description.

In 4-line system, the ML9055A interfaces with a microcomputer by 4 lines namely \overline{CS} , SCLK, SDATA, and RS.

If \overline{CS} holds “L”, the display data and command write operations can be executed consecutively. At this time, the chip select setup time, t_{CSS} , stipulates the time up to the first falling edge of SCLK after the falling edge of \overline{CS} . And the chip select hold time, t_{CSH} , stipulates the time from the rising edge of the last SCLK up to the rising edge of \overline{CS} .

Parallel Interface Timing Diagram for 68-Series MPU

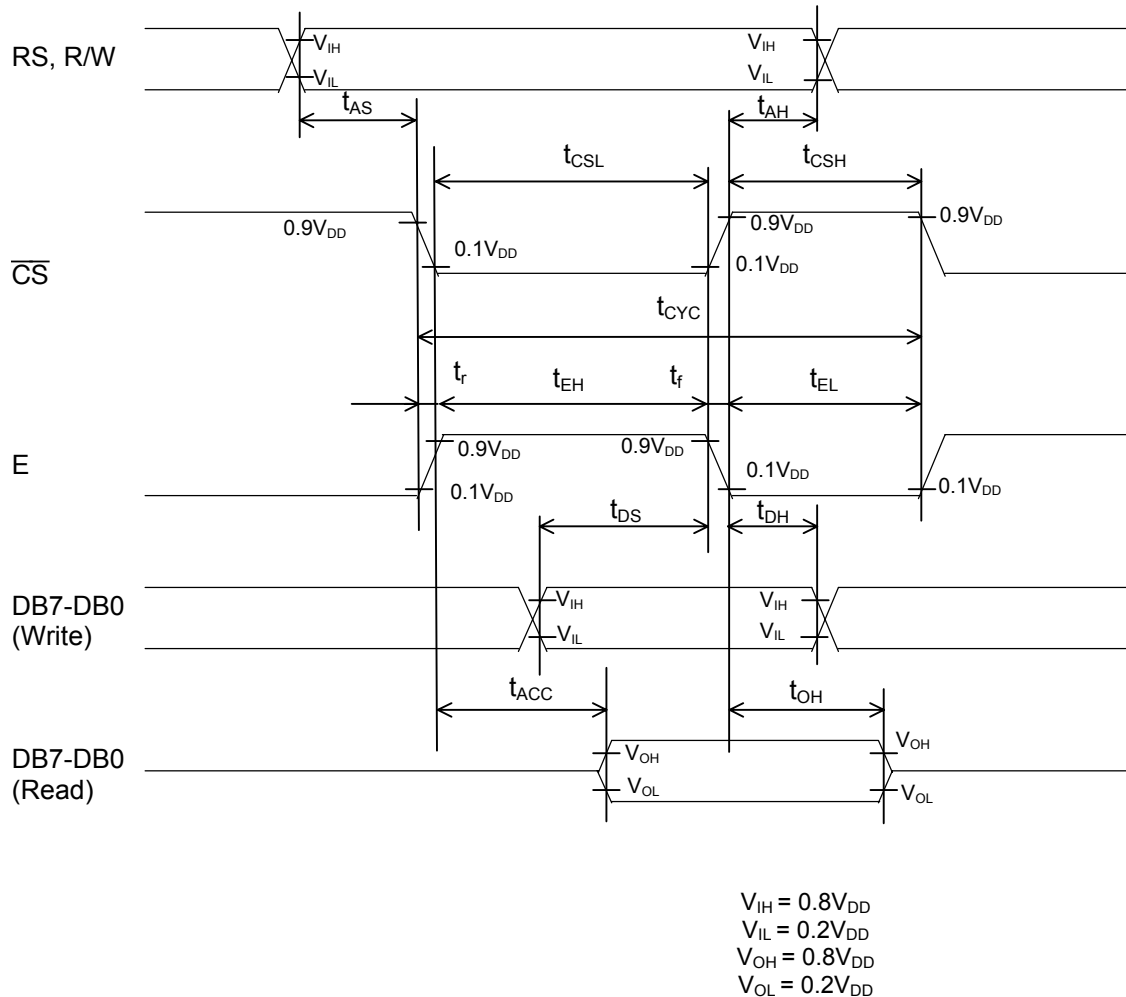

Note 1: The trace impedance (specially, the V_{DD} , V_{SS} , V_{CI} impedance and the data bus trace capacitance etc.) between this chip and circuit board should be designed as low as possible. Factors such as not sufficiently low trace impedance, LCD panel of large size, and high trace impedance of the microcomputer interface, would become a cause of the ML9055A malfunction. In such a situation, use the microcomputer interface not for reading, but for writing only to reduce the power supply noise.

Note 2: The system cycle time t_{CYC} at write and at read is different in the ML9055A. Please keep to the system write time cycle when switching from the write operation to the read operation and, similarly, keep to the system read time cycle when switching from the read operation to the write operation.

Note 3: The overlapping duration when \overline{CS} is "L" and E is "H" must satisfy t_{CSL} or t_{EH} . Reference points t_{AS} and t_{ACC} in this case are decided by \overline{CS} or E, whichever is slower, and the reference points t_{AH} , t_{DS} , t_{DH} and t_{OH} are decided by \overline{CS} or E, whichever is faster.

FUNCTIONAL DESCRIPTION

Microcomputer Interface

- Serial Interface

The ML9055A communicates with a microcomputer via clock-synchronized serial interface when PS0 holds “L”. Read operation is inhibited in the serial interface. Write operation is executed only when \overline{CS} is low.

Data should be input from the most significant bit (MSB). The data latches to the internal shift registers on the rising edge of the serial clock SCLK, and then processed as 8-bit data on the rising edge of the 8th clock. When display data is written to the RAM, the column address is incremented automatically by one only. If \overline{CS} holds “L”, the serial data can be input continuously. If \overline{CS} goes “H” before 8 serial clocks are sent while the serial data is being input, the discontinued bytes become an invalid data, but the data transmitted prior to that is valid.

The serial interface includes a 3-line serial interface and a 4-line serial interface.

When PS1 is “L”, the 3-line serial interface is selected. The 3-line serial interface is composed of serial data (SDATA), serial clock (SCLK), and chip select (\overline{CS}). The set display data length command identifies whether the data from a microcomputer is a display data or a command data. The specified number of bytes (1 to 256) in data that follow the set display data length command is processed as the display data. And the next byte, after sending the number of display data bytes specified by the set display data length command, is processed as the command data.

If \overline{CS} goes “H” while the number of bytes of serial data specified by the set display data length command is being input, the discontinued bytes become an invalid data. And the bytes sent prior to the transmitted data is a valid data. The next input data will be processed as the command data.

When PS1 is “H”, the 4-line serial interface is selected. The 4-line serial interface is composed of serial data (SDATA), serial clock (SCLK), chip select (\overline{CS}), and register select (RS). The register select pin RS is used to differentiate whether the data sent from a microcomputer is a display data or a command data. At RS pin = “H”, the input data is a display data. And at RS pin = “L”, the input data is a command data.

Note: Do not use the ML9055A with \overline{CS} tied to “L”. Make sure to return the \overline{CS} to “H” at the end of a command or data input. However, use the ML9055A with \overline{CS} at “L” when the set display data length command only is input, including the input data, at the end of this command. Return the \overline{CS} to “H” at the end of all data input.

- Parallel Interface

The ML9055A communicates with a microcomputer via the parallel interface when the PS0 is "H". The ML9055A includes a parallel interface for 68-series MPU and a parallel interface for 80-series MPU.

When both PS0 and PS1 are "H", the interface is an 8-bit parallel interface for 68-series MPU. Both read and write operations are performed only when the Chip Select (\overline{CS}) pin is "L" and E clock (E) pin is "H". The Register Select (RS) pin is used to discriminate whether the data accessed from a microcomputer is a display data or a command data. When the RS pin is "H", the accessed data is a display data. And when the RS pin is "L", the accessed data is a command data.

Table 1-1. Parallel Interface Function (68-series MPU)

(× Don't care)

E clock (E)	Register Select (RS)	Chip Select (\overline{CS})	Read/Write (R/W)	Operation
H	L	L	L	Write command data.
H	L	L	H	Read status register.
H	H	L	L	Write display data.
H	H	L	H	Read display data.
L	×	×	×	Invalid
×	×	H	×	Invalid

When PS0 is "H" and PS1 is "L", the interface is an 8-bit parallel interface for 80-series MPU. Both read and write operations are performed only when the Chip Select (\overline{CS}) is "L". The Register Select (RS) pin is used to discriminate whether the data accessed from a microcomputer is a display data or a command data. When the RS pin is "H", the accessed data is a display data. And when the RS pin is "L", the accessed data is a command data.

Table 1-2. Parallel Interface Function (80-series MPU)

(× Don't care)

Chip Select (\overline{CS})	Register Select (RS)	Write (\overline{WR})	Read (\overline{RD})	Operation
L	L	L	H	Write command data.
L	L	H	L	Read status register.
L	H	L	H	Write display data.
L	H	H	L	Write display data.
L	×	H	H	Invalid
H	×	×	×	Invalid

Note: Do not simultaneously input "L" to \overline{WR} and \overline{RD} to avoid the ML9055A malfunction.

LCD Drive Power Supply Circuit

The LCD drive power supply circuit composed of a voltage multiplier (VC), a voltage regulator (VR), and a voltage follower (VF) is controlled by the set power supply configuration instruction.

Table 2. Power Supply Circuit Configuration

Configuration	Power supply configuration (Note 1) (VC VR VF)	LCD drive power supply circuit			Pin state (Note 2)		
		VC	VR	VF	VOUT	V0	V1 – V4
All internal LCD drive power supply circuits used	1 1 1	ON	ON	ON	Output	Output	Output
Voltage regulator and voltage follower used	0 1 1	OFF	ON	ON	External input	Output	Output
Voltage follower only used	0 0 1	OFF	OFF	ON	Shorted with V0	External input	Output
External power supply used	0 0 0	OFF	OFF	OFF	Shorted with V0	External input	External input

Note 1: Although the set power supply configuration instruction allows to input commands to perform settings also of combinations other than shown in Table 2, do not perform such settings as would cause the ML9055A malfunction.

Note 2: When the pin state is “output”, connect the specified capacitors to VOUT, V0 and V1 to V4.

- Voltage multiplier

The voltage multiplier is used to increase the VCI voltage applied to VCI pin up to the set multiple value. The setting enable voltage multiples are ×3, ×4, ×5, and ×6. These multiples are set by the voltage multiplication instruction. After voltage multiplication, the voltage is output from VOUT pin, which is used as a power supply for the voltage regulator and voltage follower.

A voltage multiplier is configured in conjunction with external capacitors. As shown in Figure 1, to configure ×3 to ×6 multiplications, connect appropriate capacitors to the chip externally. Connect the capacitors to configure a voltage multiplier with the maximum multiplication used. Do not set the voltage multiplication by a command larger than the enable setting by the external capacitors because it would become a cause of the ML9055 unstable operation.

Note: Use the voltage multiplier output voltage VOUT, and the LCD drive voltage V0, at the recommended operating voltage 16.0 V or below.

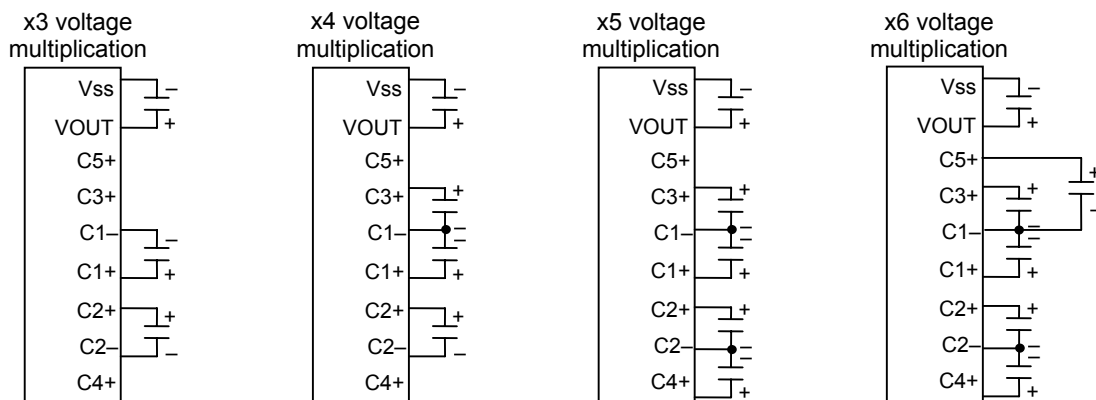

Figure 1. Voltage Multiplier Setting (C = 0.8 μF to 5.7 μF)

• Voltage Regulator Circuit

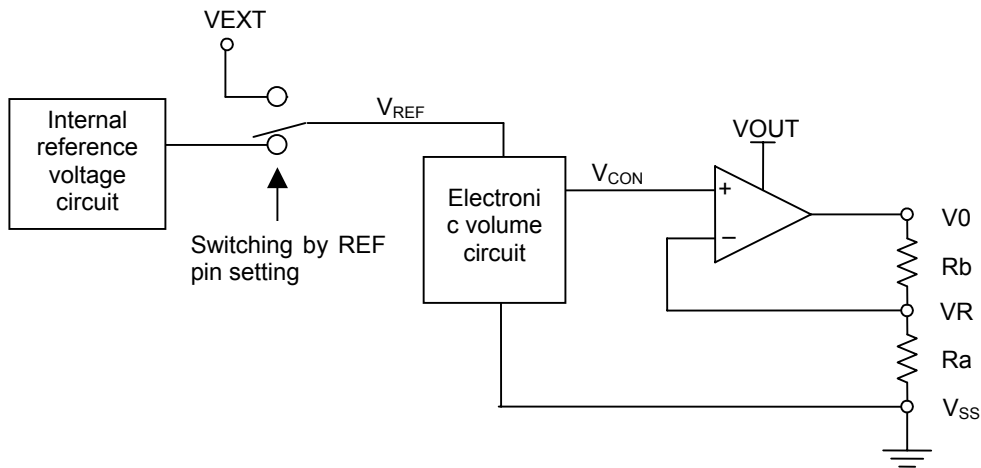

Figure 2. Voltage Regulator Circuit

The voltage regulator is composed of an internal reference voltage circuit, an electronic volume circuit, and an amplifier circuit. The internal reference voltage circuit outputs the reference voltage, $V_{REF} = 2.1 \text{ V}$ ($T_j = 25^\circ\text{C}$). This reference voltage V_{REF} has a temperature co-efficient of $0.125\%/^\circ\text{C}$.

The reference voltage V_{REF} is input to the electronic volume circuit. V_{REF} can be input from VEXT pin also by the set REF pin instruction. (Refer to Table 3.)

Table 3. V_{REF} Voltage at $T_j = 25^\circ\text{C}$

REF	Temp. coefficient	V_{REF} (V)
L	(Depends on externally connected power supply.)	VEXT pin value
H	$-0.125\%/^\circ\text{C}$	2.1 V

The electronic volume circuit converts the input reference voltage, V_{REF} , to the contrast control voltage, V_{CON} , expressed by the following equation:

$$V_{CON} = (1 - (63 - a)/210) \times V_{REF}$$

Here, parameter “a” is the contrast setting value shown in Table 4. (Levels 0 to 63 can be set.)

Table 4. Contrast Setting Value

Contrast setting value						Parameter
C5	C4	C3	C2	C1	C0	a
0	0	0	0	0	0	0
0	0	0	0	0	1	1
0	0	0	0	1	0	2
0	0	0	0	1	1	3
0	0	0	1	0	0	4
⋮						⋮
1	1	1	1	1	0	62
1	1	1	1	1	1	63

The contrast control voltage V_{con} , that is output from the electronic volume circuit, is input to the amplifier circuit and amplified to the LCD drive voltage V_0 , expressed by the following equation by the ratio of resistor R_a to R_b .

$$V_0 = (1 + R_b/R_a) \times V_{CON}$$

Resistor R_a and resistor R_b can select either internal or external resistor by INTRS pin setting.

- Internal Resistor Configuration

When “H” is input to INTRS pin, resistor R_a and resistor R_b in the IC are selected. The resistance ratio R_b/R_a is determined by the set internal resistance ratio command. Table 5 shows amplification factor of the amplifier circuit.

Figure 3 shows the variable range of LCD drive voltage V_0 at $T_j = 25^\circ\text{C}$ when using the internal resistors.

Table 5. Internal Resistance Ratio Setting

Internal resistance ratio setting value	Amplification factor
R2 R1 R0	$1 + R_b/R_a$
0 0 0	2.3
0 0 1	3.0
0 1 0	3.7
0 1 1	4.4
1 0 0	5.1
1 0 1	5.8
1 1 0	6.5
1 1 1	7.2

- External Resistor Configuration

When “L” is input to the INTRS pin, the internal resistors are separated and the externally connected resistors R_a and R_b set the amplification factor. Similar to Figure 2, connect an external resistor R_a across V_R and V_{SS} pins, and an external resistor R_b across V_R and V_0 pins.

Note: The sum of the externally connected resistors R_a and R_b should be in the 500 k Ω to 5 M Ω range.

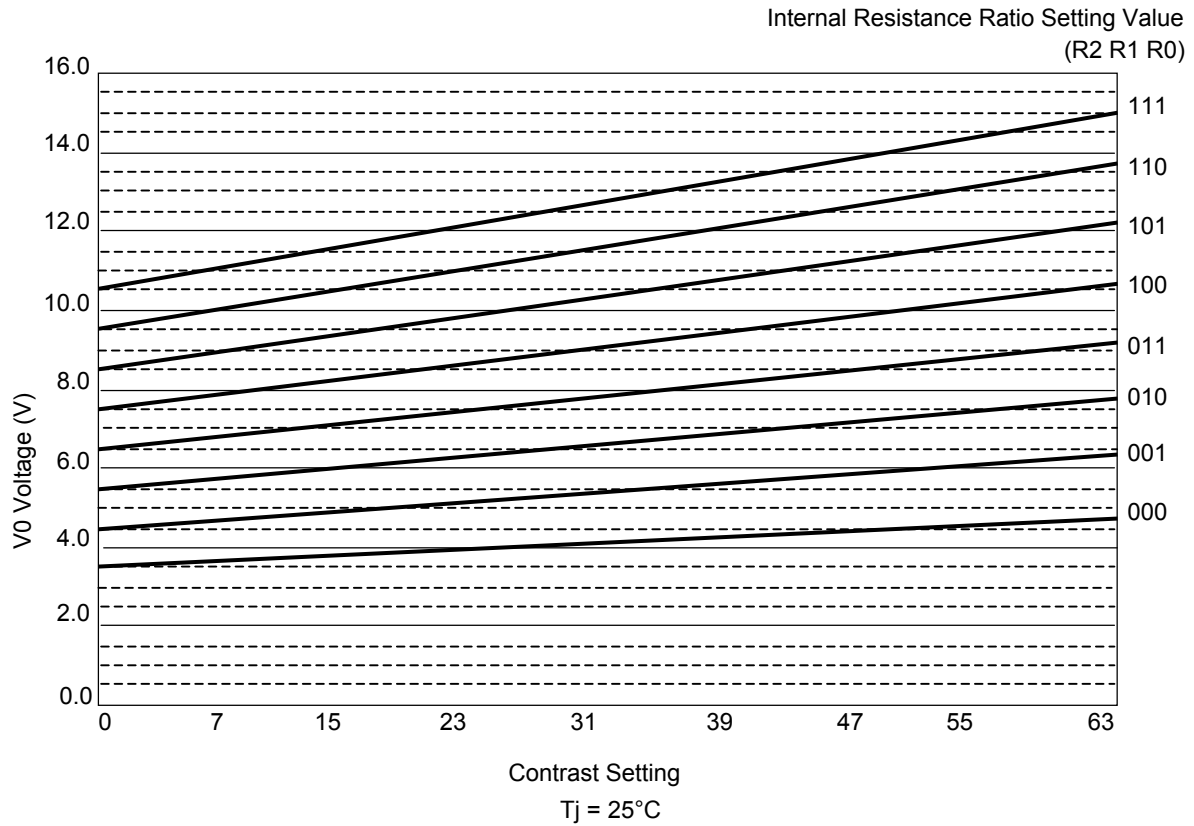

Figure 3. V0 Variable Range When Using Internal Reference Voltage and Internal Resistors

- Voltage Follower Circuit

With LCD drive voltage V0 as a reference voltage, 4 LCD drive bias voltages are generated. The LCD bias is determined by the set LCD bias ratio command. The available bias levels are: 1/5, 1/6, 1/7, 1/8, 1/9, 1/10, 1/11, and 1/12. Connect capacitors of 0.376 μF to 2.4 μF to the voltage follower outputs for stabilizing the voltage.

To determine optimal bias setting:

Let the display duty be 1/D, then the optimal bias ratio is $1/(1 + \sqrt{D})$.

Table 6. LCD Drive Voltage Levels vs. Bias

LCD drive bias ratio	V1	V2	V3	V4
1/n	$(n-1)/n \times V0$	$(n-2)/n \times V0$	$2/n \times V0$	$1/n \times V0$

• Power Supply Configuration Examples

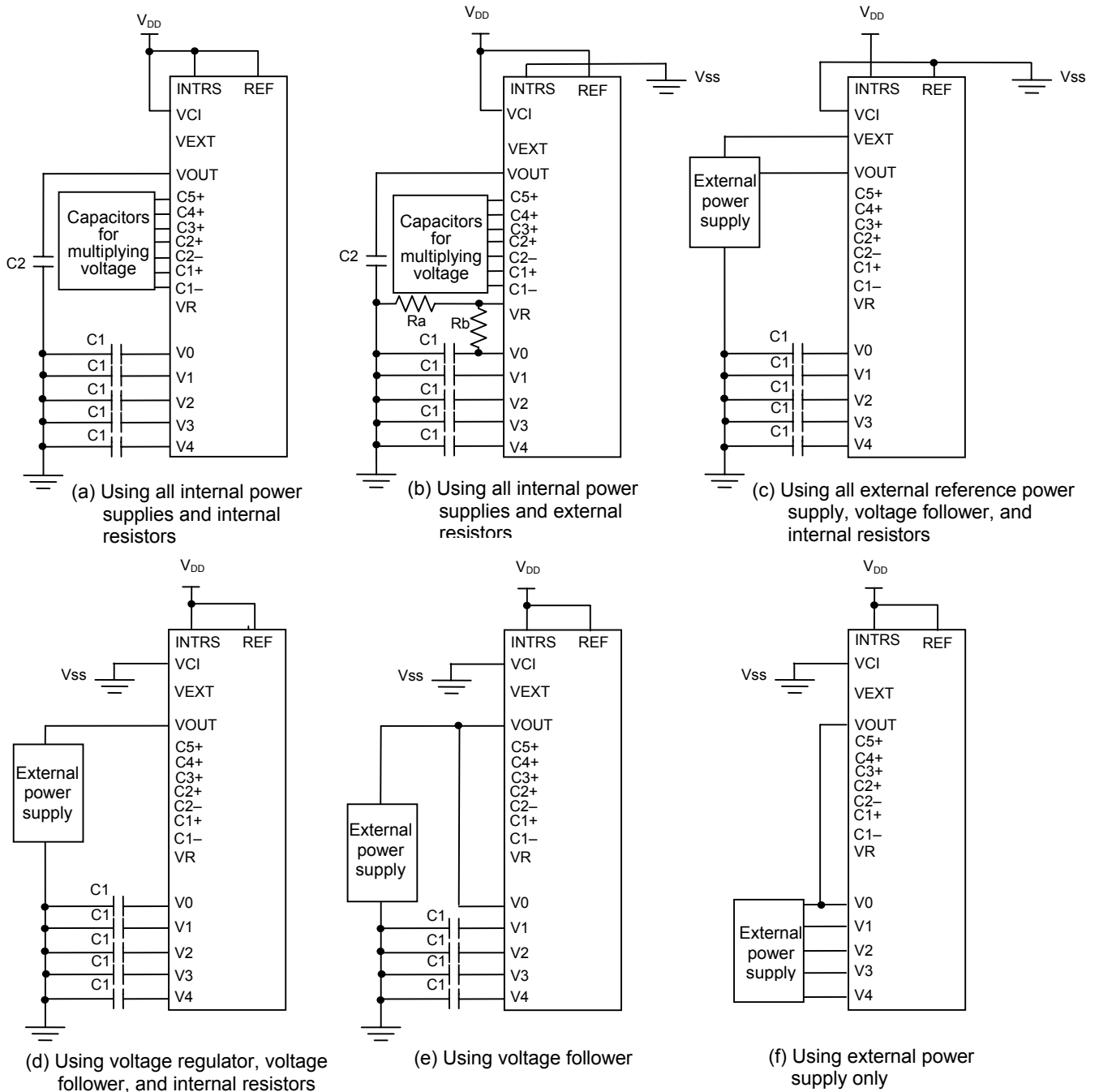

Figure 4. Power Supply Configuration Examples

Note 1: The bias capacitor C1 connected to the LCD drive bias pin should be in the 0.376 μF to 2.4 μF range. And the capacitors for multiplying voltage connected to the connect pins for these capacitors, and stabilizing capacitor C2 connected to the voltage multiplier input/output pin VOUT should be in the 0.8 μF to 5.7 μF range.

Note 2: In the case of using an external power supply, apply V_{SS} to pin VCI. And when not using an external reference voltage, keep the pin VEXT open.

Partial Display Function

The set display lines count instruction allows the display duty to be set to any value from 1/16 duty to 1/128 duty line-by-line, and also allows the display duty to be set according to the used panel.

Also, the partial display function can display a part of the common lines only on the used LCD panel out of the total common lines, and accordingly sets the supply voltages, bias ratio and voltage multiplication thus reducing the current consumption. The method of changing the number of display lines is described in the “Partial Display Change Sequence” section of the OPERATING SEQUENCE.

Display Data RAM

For performing the bit-map display in the ML9055A, the data RAM is arranged into 2-dimensional 128 rows \times 128 columns corresponding to the display image, and a specific element is specified by the row address (0 to 127) and column address (0 to 127). Each element stores a 2-bit data that indicates the level of gradation i.e., gray scale, of a pixel corresponding to an element. (Refer to Figure 5.)

The relationship between COM output numbers and RAM row addresses can be reversed by the set COM scan direction command. The relationship between SEG output numbers and RAM column addresses can be reversed by the ADC select command. This enhances the freedom in relationship between the panel and chip location at the time of implementation.

Moreover, it is possible to provide an offset to the row addresses and COM numbers by the set scanning start COM command allowing to scroll a display in the common direction. (Refer to Figure 6.)

Since the microcomputer interface data is in bytes, the data for 8 pixels of 8 rows \times 1 column is collectively handled as 1 byte. For this reason, the RAM read/write location is specified by the upper 4 bits of a row address (called a page address) and a column address. In byte, the larger row address side is positioned to the upper bit side. Since 1 pixel data consists of 2 bits, the read/write operations are performed in the order of upper/lower bits by accessing 2 times consecutively.

As for the access procedure, the page address and column address are first set by command followed by the execution of display data read/write commands. It is not necessary to set again the column address when reading/writing the display data on the same page in the order of column address by the column address automatic increment function. Meanwhile, when reading, it is necessary to read a dummy display data once between the address setting and display data reading. For additional details, refer to the Display Data Write Sequence, Display Data Read Sequence, and Read Modify Write Sequence in the OPERATING SEQUENCE section.

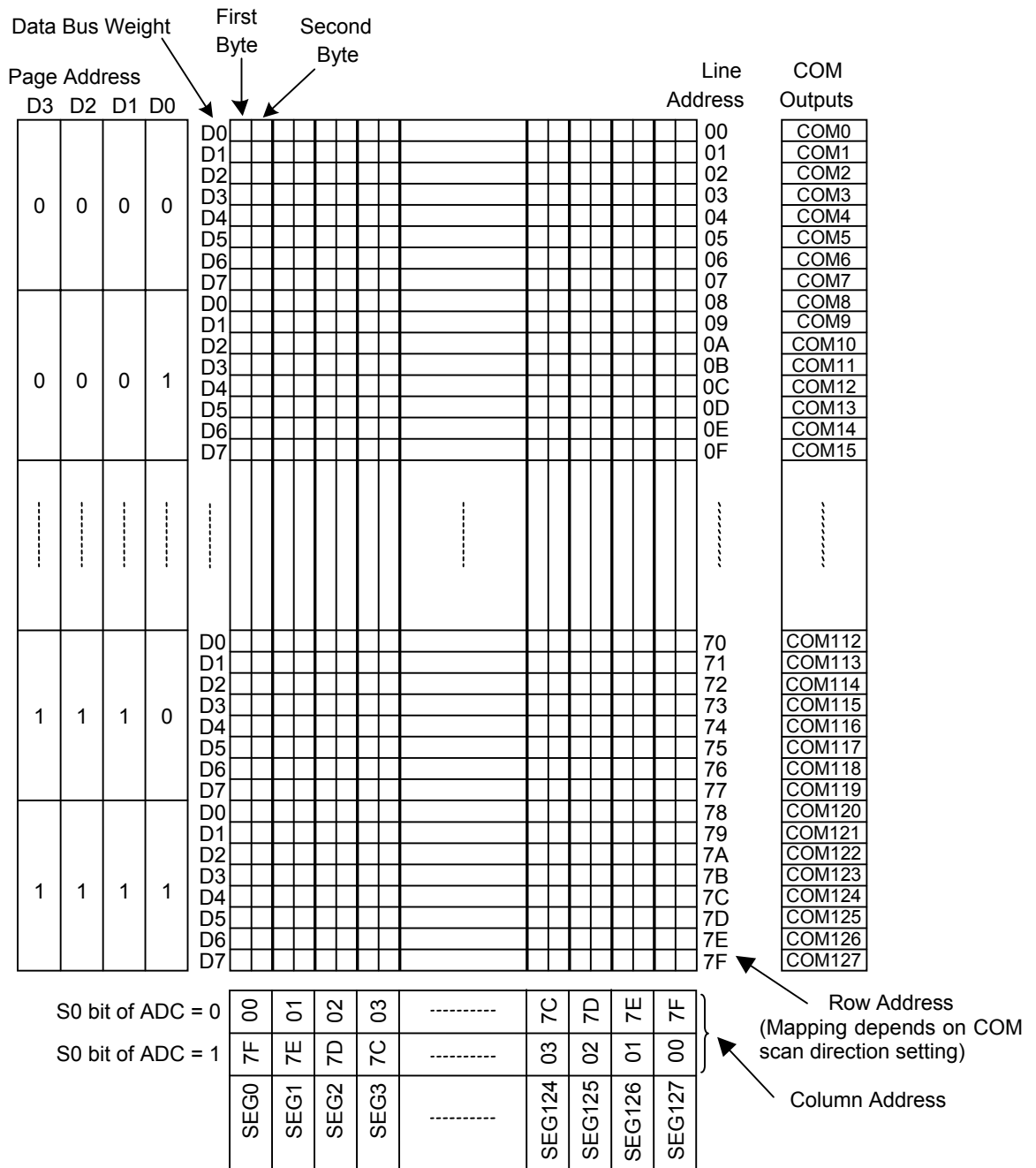
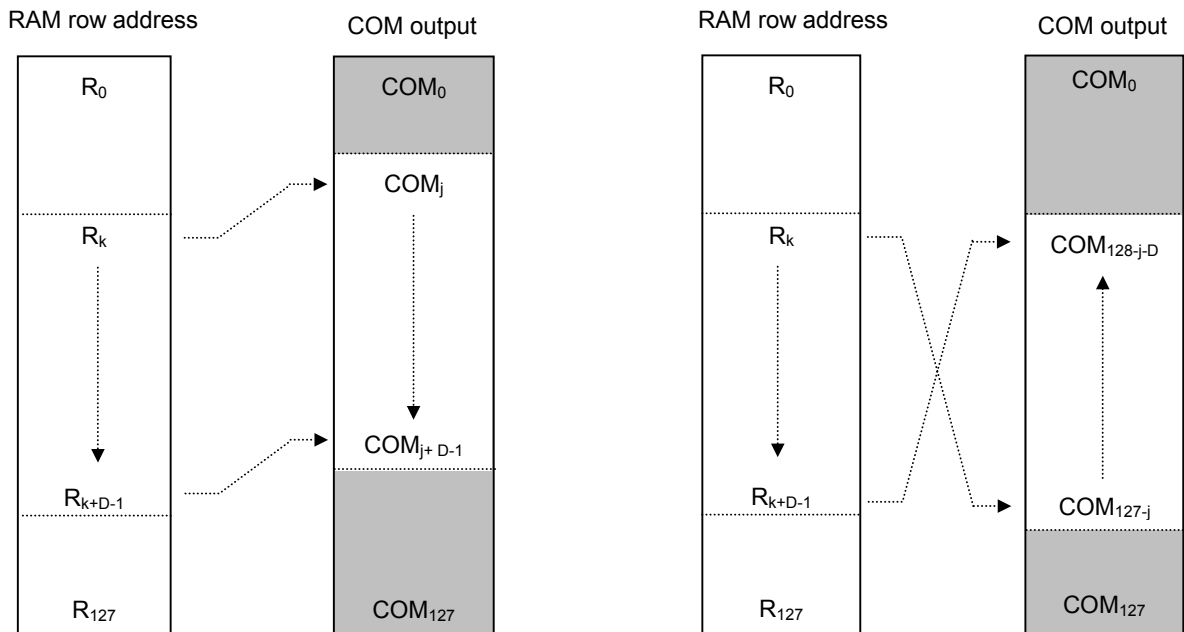
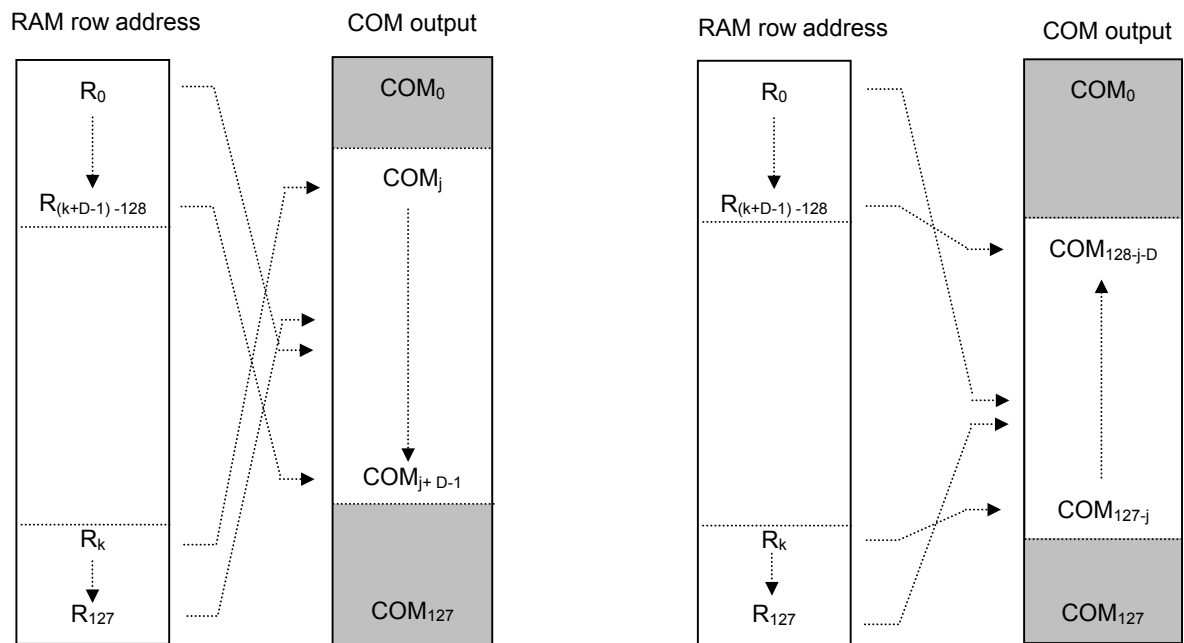

Figure 5. Display Data RAM Map



(a) COM scan direction $SC0 = 0$
 Scan start COM setting = j
 Display start row address setting = k
 Display line count setting = D

(b) COM scan direction $SC0 = 1$
 Scan start COM setting = j
 Display start row address setting = k
 Display line count setting = D



(c) COM scan direction $SC0 = 0$
 Scan start COM setting = j
 Display start row address setting = k
 Display line count setting = D
 In the case of $j+D > 128$

(b) COM scan direction $SC0 = 1$
 Scan start COM setting = j
 Display start row address setting = k
 Display line count setting = D
 In the case of $j+D > 128$

Figure 6. Relationship Between RAM Row Address Setting and COM Output

Gray Scale Display

In order to perform 4 gray scales (black, dark gray, light gray, and white) on a display, the ML9055A can set the lighting level pulse width of a segment drive waveform every frame for the 2-bit display data. This allows the ML9055A to support 2 modulation methods: pulse width modulation (PWM) and frame modulation (FRC), which in turn allows flexible setting according to the panel characteristics.

For the frame cycle, which performs modulation, 3 frames or 4 frames can be selected by the set FRC field of FRC/PWM mode command. And 9, 12 or 15 can be selected as the number of PWM pulse width setting steps by the PWM1 and PWM0 fields, and the lighting pulse width of every frame of each gray scale is set by the set pulse width command. (Refer to Tables 7 and 8.)

Example: In the setting (inversion display off) shown in Table 9, in pixels of the display RAM data 11, all the 3 frames output the segment drive waveform of pulse width 9/9 (driver voltage effective value maximum). Similarly, in pixels of the RAM data 10, the 1st and 2nd frames output the segment drive waveform of pulse width 9/9, and the 3rd frame outputs pulse width 0/9. In pixels of the RAM data 01, the 1st frame, 2nd frame and 3rd frame output the segment drive waveform of pulse width 9/9, 3/9 and 0/9, respectively. In pixels of the RAM data 00, all 3 frames output the segment drive waveform of pulse width 0/9 (driver voltage effective value minimum).

Note: In order to avoid the occurrence of DC offset when using the 4-frame FRC, determine the pulse width setting values of each gray scale such that the sum of values of even number frames is equal to the sum of values of odd number frames.

Table 7. PWM Binary Setting for 4-frame FRC

RAM bit (1st Byte/ 2nd Byte)	G/S	PWM Binary Setting			
		1st frame PWM	2nd frame PWM	3rd frame PWM	4th frame PWM
11	Black	(BA3–BA0)	(BB3–BB0)	(BC3–BC0)	(BD3–BD0)
10	Dark Gray	(DA3–DA0)	(DB3–DB0)	(DC3–DC0)	(DD3–DD0)
01	Light Gray	(LA3–LA0)	(LB3–LB0)	(LC3–LC0)	(LD3–LD0)
00	White	(WA3–WA0)	(WB3–WB0)	(WC3–WC0)	(WD3–WD0)

Table 8. PWM Binary Setting for 3-frame FRC

RAM bit (1st Byte/ 2nd Byte)	G/S	PWM Binary Setting		
		1st frame PWM	2nd frame PWM	3rd frame PWM
11	Black	(BA3–BA0)	(BB3–BB0)	(BC3–BC0)
10	Dark Gray	(DA3–DA0)	(DB3–DB0)	(DC3–DC0)
01	Light Gray	(LA3–LA0)	(LB3–LB0)	(LC3–LC0)
00	White	(WA3–WA0)	(WB3–WB0)	(WC3–WC0)

Table 9. Example of PWM Binary Setting (3-frame FRC and 9-level PWM)

G/S	PWM Binary Setting		
	1st frame PWM	2nd frame PWM	3rd frame PWM
Black	1001	1001	1001
Dark Gray	1001	1001	0000
Light Gray	1001	0011	0000
White	0000	0000	0000

Table 10. 9-Level PWM Settings

Decimal Value	Binary Setting(*1)	PWM Setting	Visual Appearance
0	0000	0	Lightest
1	0001	1/9	
2	0010	2/9	
3	0011	3/9	
4	0100	4/9	
5	0101	5/9	
6	0110	6/9	
7	0111	7/9	
8	1000	8/9	
9	1001	1	Darkest
10	1010	0	Set to lightest level.
11	1011	0	
12	1100	0	
13	1101	0	
14	1110	0	
15	1111	0	

(*1) The binary setting value can be any one of WA3-0, LA3-0, DA3-0, BA3-0, WB3-0, LB3-0, DB3-0, BB3-0, WC3-0, LC3-0, DC3-0, BC3-0, WD3-0, LD3-0, DD3-0, and BD3-0.

Table 11. 12-Level PWM Settings

Decimal Value	Binary Setting(*1)	PWM Setting	Visual Appearance
0	0000	0	Lightest
1	0001	1/12	
2	0010	2/12	
3	0011	3/12	
4	0100	4/12	
5	0101	5/12	
6	0110	6/12	
7	0111	7/12	
8	1000	8/12	
9	1001	9/12	
10	1010	10/12	
11	1011	11/12	
12	1100	1	Darkest
13	1101	0	Set to lightest level.
14	1110	0	
15	1111	0	

(*1) The binary setting value can be any one of WA3-0, LA3-0, DA3-0, BA3-0, WB3-0, LB3-0, DB3-0, BB3-0, WC3-0, LC3-0, DC3-0, BC3-0, WD3-0, LD3-0, DD3-0, and BD3-0.

Table 12. 15-Level PWM Settings

Decimal Value	Binary Setting(*1)	PWM Setting	Visual Appearance
0	0000	0	Lightest
1	0001	1/15	
2	0010	2/15	
3	0011	3/15	
4	0100	4/15	
5	0101	5/15	
6	0110	6/15	
7	0111	7/15	
8	1000	8/15	
9	1001	9/15	
10	1010	10/15	
11	1011	11/15	
12	1100	12/15	
13	1101	13/15	
14	1110	14/15	
15	1111	1	Darkest

(*1) Binary Setting Values are WA3-0, LA3-0, DA3-0, BA3-0, WB3-0, LB3-0, DB3-0, BB3-0, WC3-0, LC3-0, DC3-0, BC3-0, WD3-0, LD3-0, DD3-0, or BD3-0.

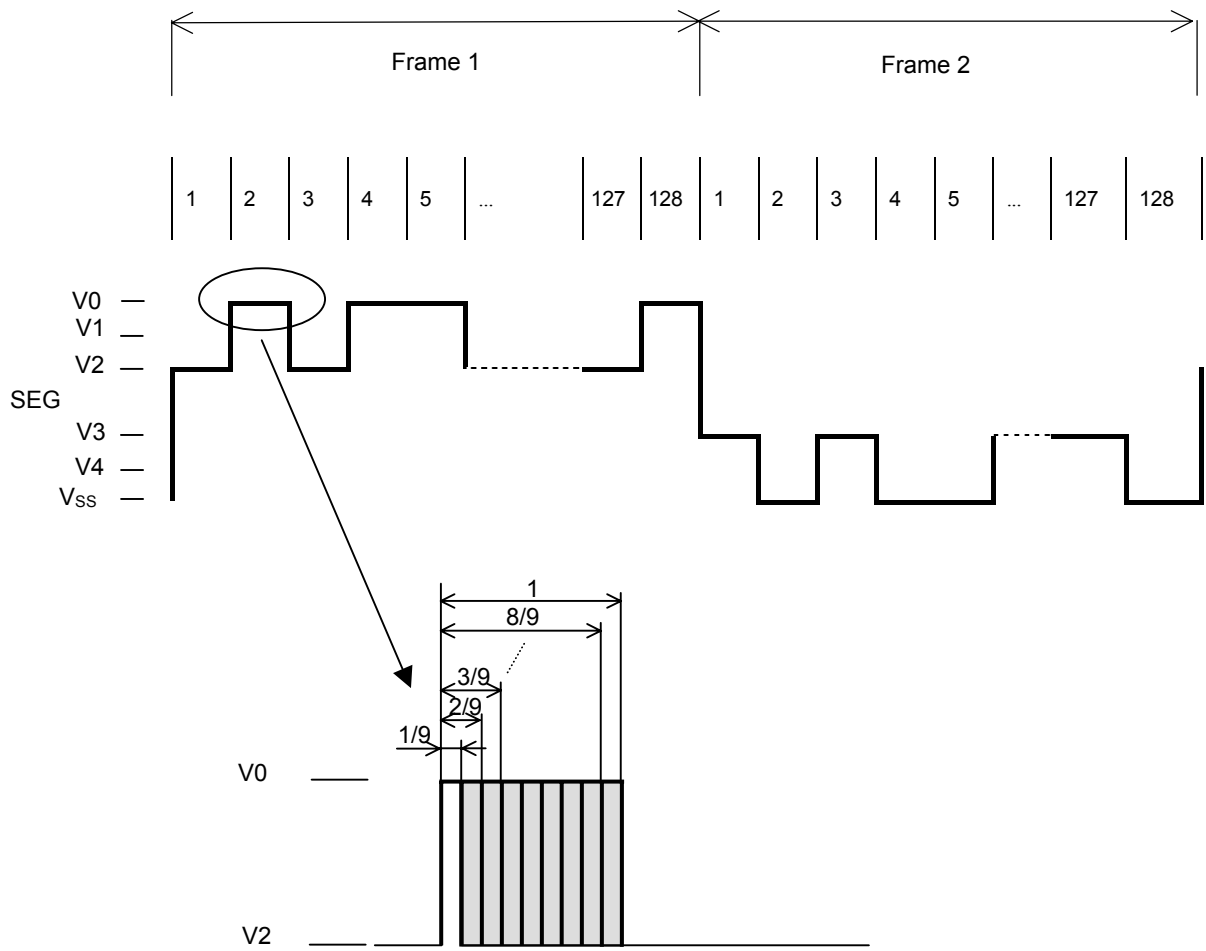

Figure 7. Example of 9-Level PWM Segment Waveform

Instruction Description

Table 13. Instruction Set List

										x: Don't care	
RS	R/W	D7	D6	D5	D4	D3	D2	D1	D0	Description	
0	1	BUSY	ON	RES	1	0	1	1	0	Read internal status.	
1	0	Write data								Write display data.	
1	1	Read data								Read display data.	
0	0	0	0	0	0	C3	C2	C1	C0	Set column address (lower digits).	
0	0	0	0	0	1	0	C6	C5	C4	Set column address (upper digits).	
0	0	1	0	1	1	P3	P2	P1	P0	Set page address.	
0	0	1	1	1	0	0	0	0	0	Set read modify write mode.	
0	0	1	1	1	0	1	1	1	0	Release read modify write mode.	
0	0	0	0	1	0	0	R2	R1	R0	Set internal resistance ratio.	
0	0	0	0	1	0	1	VC	VR	VF	Set power supply configuration.	
0	0	0	1	0	0	0	0	x	x	Set scan start COM.	
0	0	x	L6	L5	L4	L3	L2	L1	L0		
0	0	0	1	0	0	0	1	x	x	Set initial display line address.	
0	0	x	C6	C5	C4	C3	C2	C1	C0		
0	0	0	1	0	0	1	0	x	x	Set number of display lines.	
0	0	D7	D6	D5	D4	D3	D2	D1	D0		
0	0	0	1	0	0	1	1	x	x	Set N-line inversion.	
0	0	x	x	x	N4	N3	N2	N1	N0		
0	0	1	1	1	0	0	1	0	0	Release N-line inversion.	
0	0	0	1	0	1	0	BI2	BI1	BI0	Set LCD bias ratio.	
0	0	0	1	1	0	0	1	BO1	BO0	Set voltage multiplication.	
0	0	1	0	0	0	0	0	0	1	Set contrast.	
0	0	x	x	C5	C4	C3	C2	C1	C0		
0	0	1	0	1	0	0	0	0	S0	Select ADC.	
0	0	1	1	0	0	SC0	x	x	x	Set COM scan direction.	
0	0	1	0	1	0	0	1	0	E0	Light all dots.	
0	0	1	0	1	0	0	1	1	R0	Reverse display on/off	
0	0	1	0	1	0	1	0	0	1	Set power save mode.	
0	0	1	1	1	0	0	0	0	1	Release power save mode.	
0	0	1	0	1	0	1	0	1	1	Start internal oscillator circuit.	
0	0	1	0	1	0	1	1	1	DI0	Display on/off.	
0	0	1	1	1	0	0	0	1	0	Reset	
x	x	1	1	1	0	1	0	0	0	Set display data length. (Used in 3-line interface only.)	
x	x	D7	D6	D5	D4	D3	D2	D1	D0		
0	0	1	0	0	1	0	FRC	PWM1	PWM0	Set PWM/FRC mode.	
0	0	1	0	0	0	1	0	0	0	Gray scale register setting	Set white pulse width, 1/2.
0	0	WB3	WB2	WB1	WB0	WA3	WA2	WA1	WA0		Set white pulse width, 3/4
0	0	1	0	0	0	1	0	0	1		Set light gray pulse width, 1/2.
0	0	WD3	WD2	WD1	WD0	WC3	WC2	WC1	WC0		
0	0	1	0	0	0	1	0	1	0		Set light gray pulse width, 3/4
0	0	LB3	LB2	LB1	LB0	LA3	LA2	LA1	LA0		
0	0	1	0	0	0	1	0	1	1		Set dark gray pulse width, 1/2
0	0	LD3	LD2	LD1	LD0	LC3	LC2	LC1	LC0		
0	0	1	0	0	0	1	1	0	0		Set dark gray pulse width, 3/4
0	0	DB3	DB2	DB1	DB0	DA3	DA2	DA1	DA0		
0	0	1	0	0	0	1	1	0	1		Set black pulse width, 1/2.
0	0	DD3	DD2	DD1	DD0	DC3	DC2	DC1	DC0		
0	0	1	0	0	0	1	1	1	0		Set black pulse width, 3/4
0	0	BB3	BB2	BB1	BB0	BA3	BA2	BA1	BA0		
0	0	1	0	0	0	1	1	1	1	Test instruction for supplier exclusive use	
0	0	BD3	BD2	BD1	BD0	BC3	BC2	BC1	BC0		
0	0	1	1	1	1	x	x	x	x		

- Read Internal Status

This command is only available in the parallel interface mode.

RS	R/W	D7	D6	D5	D4	D3	D2	D1	D0	Description
0	1	BUSY	ON	RES	1	0	1	1	0	Read internal status

BUSY 0: Chip is idle.

1: Chip is executing an instruction.

When this bit is “1”, it indicates that this chip is executing an instruction. Normally it is not necessary to read the internal status because the command execution processing is completed in 1 system cycle time (t_{CYC}). The reset operation by $\overline{\text{RESET}}$ pin does not pull this bit to “1”. Refer to the RES bit described below.

ON 0: Display is OFF.

1: Display is ON.

RES 0: Chip is in operating state.

1: Chip is executing the reset.

This bit goes “1” during the execution of the reset either by $\overline{\text{RESET}}$ pin or by the reset command. Other commands cannot be executed while the reset is being executed. Since the reset execution processing is completed in 1 system cycle time, the next command can be input without reading this bit if wait-time of 1 system write cycle time (t_{CYC}) is taken after the $\overline{\text{RESET}}$ pin is pulled to “H” or after having executed reset by the reset command.

- Write Display Data

The display data is written on to the display RAM at a location specified by the page address and column address. If using the 3-line serial interface, the set data display length command must be executed prior to inputting the display data. Column address automatically increments by one after every 2-byte data write operation, and returns to 0 after data is written to the last column address (7F). The page address does not increment even if the column address has returned to 0. The RAM must be written in 2 successive bytes because the 2-bit data for each pixel is written in 2 times. Refer to Figure 5 for the data structure. And about the write operation, refer to the Display Data Write Sequence.

RS	R/W	D7	D6	D5	D4	D3	D2	D1	D0	Description
1	0	Write data								Write display data.

- Read Display Data

Data is read from the display RAM at a location specified by the page address and column address. The column address increments automatically by one every 2-byte read operation, and returns to 0 after the data of last column address (7F) is read. The page address does not increment even if the column address has returned to 0. Dummy (1 byte) data reading is required once after the address setting, and the display data is read after having read that dummy data.

For additional details on the read operation, refer to the Display Data Read Sequence. This command is available in the parallel interface mode only.

RS	R/W	D7	D6	D5	D4	D3	D2	D1	D0	Description
1	1	Read data								Read display data

- Set Column Address

Specifies the column address (0 to 127) of the write/read destinations of display data. The column address increments automatically by one every 2 times a write display data command or a read display command is executed.

It does not matter to execute the higher digit setting or the lower digit setting of a column address first. It is also possible to execute only either the higher digit setting or the lower digit setting of a column address.

RS	R/W	D7	D6	D5	D4	D3	D2	D1	D0	Description
0	0	0	0	0	0	C3	C2	C1	C0	Set column address (lower digits).
0	0	0	0	0	1	0	C6	C5	C4	Set column address (higher digits).

- Set Page Address

Specifies the read/write destination page address (0 to 15) of the display data.

RS	R/W	D7	D6	D5	D4	D3	D2	D1	D0	Description
0	0	1	0	1	1	P3	P2	P1	P0	Set page address

- Set Read Modify Write Mode

In this mode, data is read from the display RAM at a location specified by the page address and column address, and the data is written to the same page address and column address. The column address does not increment after the 2-byte display data read operation, but increments by one after every 2-byte write operation. It is necessary to read a dummy data after the address setting. It is also necessary to read a dummy data after the 2-byte write operation.

The display data cannot be read through the serial interface. For additional information on the read modify write operation, refer to the Read Modify Write Mode Sequence.

RS	R/W	D7	D6	D5	D4	D3	D2	D1	D0	Description
0	0	1	1	1	0	0	0	0	0	Set read modify write mode.

- Release Read Modify Write Mode

This command will release the read modify write mode.

RS	R/W	D7	D6	D5	D4	D3	D2	D1	D0	Description
0	0	1	1	1	0	1	1	1	0	Release read modify write mode.

- Set Internal Resistance Ratio

3 bits are used to set the resistance ratio of internal resistors used in the voltage regulator.

For details on the operation of the voltage regulator by the internal resistance ratio setting, refer to the “Voltage Regulator” section.

RS	R/W	D7	D6	D5	D4	D3	D2	D1	D0	Description
0	0	0	0	1	0	0	R2	R1	R0	Set internal resistance ratio.

R2-R0	(1+Rb/Ra)
(0, 0, 0)	2.3
(0, 0, 1)	3.0
(0, 1, 0)	3.7
(0, 1, 1)	4.4
(1, 0, 0)	5.1
(1, 0, 1)	5.8
(1, 1, 0)	6.5
(1, 1, 1)	7.2

- Set Power Supply Configuration

This command sets the operation of internal power supply for every block. VC = Voltage multiplier, VR = Voltage regulator, VF = Voltage follower. (0: Off, 1: On)

Although the set power supply configuration command allows you to input commands for settings other than the combinations shown in Table 2, do not perform other settings as these would become a cause of the ML9055A malfunction.

RS	R/W	D7	D6	D5	D4	D3	D2	D1	D0	Description
0	0	0	0	1	0	1	VC	VR	VF	Set power supply configuration.

- Set Scan Start COM (2-byte instruction)

This instruction specifies the COM number to start scanning. For details on the operation of the scan start COM setting, refer to Figure 6.

RS	R/W	D7	D6	D5	D4	D3	D2	D1	D0	Description
0	0	0	1	0	0	0	0	x	x	Set scan start COM.
0	0	x	L6	L5	L4	L3	L2	L1	L0	

Note: Make sure to input the upper instruction before inputting the lower instruction.

- Set Initial Display Line Address (2-byte instruction)

This instruction is used to set the line address of display RAM that starts the display. The use of this instruction makes it possible to achieve a scroll in the vertical direction without changing the contents of the display data RAM.

For details on the operation of the initial display line address setting, refer to Figure 6.

RS	R/W	D7	D6	D5	D4	D3	D2	D1	D0	Description
0	0	0	1	0	0	0	1	x	x	Set initial display line address.
0	0	x	C6	C5	C4	C3	C2	C1	C0	

Note: Make sure to input the upper instruction before inputting the lower instruction.

- Set Display Line Count (2-byte instruction)

This instruction is used to set the duty ratio (1/16 to 1/128) of LCD display. The setting value determines the number of data lines displayed on the LCD display. The internal state does not change even by an invalid setting. For details on the operation of the display start line address setting, refer to Figure 6.

RS	R/W	D7	D6	D5	D4	D3	D2	D1	D0	Description
0	0	0	1	0	0	1	0	x	x	Set the number of lines to be displayed.
0	0	D7	D6	D5	D4	D3	D2	D1	D0	

Note: Make sure to input the upper instruction before inputting the lower instruction.

<u>D7 – D0</u>	<u>Duty Ratio</u>
0 0 0 0 0 0 0 0	Invalid
⋮	⋮
0 0 0 0 1 1 1 1	Invalid
0 0 0 1 0 0 0 0	1/16
0 0 0 1 0 0 0 1	1/17
⋮	⋮
1 0 0 0 0 0 0 0	1/128
1 0 0 0 0 0 0 1	Invalid
⋮	⋮
1 1 1 1 1 1 1 1	Invalid

- Set N-line Inversion (2-byte instruction)

This is a setting instruction to perform the N lines (3 to 33 lines) inversion drive for reducing the crosstalk noise.

RS	R/W	D7	D6	D5	D4	D3	D2	D1	D0	Description
0	0	0	1	0	0	1	1	x	x	Set N-line inversion.
0	0	x	x	x	N4	N3	N2	N1	N0	

Note 1: In order to prevent the generation of DC bias and display irregularity, or unevenness on the display, the number of lines selected should not be set to a divisor that is twice the display duty ratio. Pay attention to this condition when using the N-lines inversion.

Example: If the display duty ratio is 1/99, never set the N-line inversion to 3, 6, 9, 11, 18, 22, or 33 lines.

Note 2: Make sure to input the upper instruction before inputting the lower instruction.

<u>N4 – N0</u>	<u>Setting number of inversion lines</u>
0 0 0 0 0	0 lines (Frame inversion)
0 0 0 0 1	3 lines
⋮	⋮
1 1 1 1 0	32 lines
1 1 1 1 1	33 lines

- Release N-line Inversion

This command releases the N-line inversion setting of driver (controller), causing frame inversion to occur.

RS	R/W	D7	D6	D5	D4	D3	D2	D1	D0	Description
0	0	1	1	1	0	0	1	0	0	Release N-line inversion.

- Set LCD Bias Ratio

Sets the LCD bias ratio (1/5 – 1/12).

RS	R/W	D7	D6	D5	D4	D3	D2	D1	D0	Description
0	0	0	1	0	1	0	B12	B11	B10	Set the LCD bias ratio.

<u>B12</u>	<u>B11</u>	<u>B10</u>	<u>Bias Ratio</u>
0	0	0	1/5
0	0	1	1/6
0	1	0	1/7
0	1	1	1/8
1	0	0	1/9
1	0	1	1/10
1	1	0	1/11
1	1	1	1/12

- Set Voltage Multiplication

This command is used to set the voltage multiplication. The available multiplications are: $\times 3$, $\times 4$, $\times 5$, and $\times 6$.

RS	R/W	D7	D6	D5	D4	D3	D2	D1	D0	Description
0	0	0	1	1	0	0	1	BO1	BO0	Set voltage multiplication.

Note: Do not set the value exceeding the upper limit of voltage multiplications that are determined by the connection of external capacitors in the voltage multiplication configuration.

BO1	BO0	Voltage multiplication
0	0	$\times 3$
0	1	$\times 4$
1	0	$\times 5$
1	1	$\times 6$

- Set Contrast (2-byte instruction)

This instruction is used for fine tuning of the LCD drive voltage to adjust the display contrast. For details on the operation of contrast setting, refer to Table 4 and Figure 3.

RS	R/W	D7	D6	D5	D4	D3	D2	D1	D0	Description
0	0	1	0	0	0	0	0	0	1	Set the contrast.
0	0	x	x	C5	C4	C3	C2	C1	C0	

Note: Make sure to input the upper instruction before inputting the lower instruction.

- Select ADC

Determines the correspondence between the column address of display data RAM and the segment driver (0: From SEG0 to SEG 127, 1: From SEG127 to SEG0)

For details on the operation of ADC selection, refer to Figure 5.

RS	R/W	D7	D6	D5	D4	D3	D2	D1	D0	Description
0	0	1	0	1	0	0	0	0	S0	Select ADC.

S0	Relationship between column address and segment output
0	RAM column address i corresponds to SEG i .
1	RAM column address i corresponds to SEG127- i .

- Set COM Scan Direction

This instruction is used to set the COM (row) scan direction. (0: COM0 to COM127 direction, 1: COM127 to COM0 direction)

For details on the operation of setting the COM scan direction, refer to Figure 6.

RS	R/W	D7	D6	D5	D4	D3	D2	D1	D0	Description
0	0	1	1	0	0	SC0	x	x	x	Set the COM scan direction.

- Light All Dots

Always outputs the lighting level regardless of the contents of the display data RAM, PWM setting, and reverse display on/off command. (0 : Normal display, 1: All dots light.)

RS	R/W	D7	D6	D5	D4	D3	D2	D1	D0	Description
0	0	1	0	1	0	0	1	0	E0	Light all dots.

- Reverse Display On/Off

Reverses the gray scale level relationship of each pixel without modifying the contents of display data RAM. (0: Normal, 1: Reverse image)

RS	R/W	D7	D6	D5	D4	D3	D2	D1	D0	Description
0	0	1	0	1	0	0	1	1	R0	Reverse display on/off

RAM contents				RAM = "00"	RAM = "01"	RAM = "10"	RAM = "11"
Normal display: R0 = 0				White	Light gray	Dark gray	Black
Reverse display: R0 = 1				Black	Dark gray	Light gray	White

- Set Power Save Mode

Puts the driver (controller) into the power save mode as follows:

Oscillator circuit: Off
 LCD power supply: Off (Note)
 COM/SEG output: V_{SS}

RS	R/W	D7	D6	D5	D4	D3	D2	D1	D0	Description
0	0	1	0	1	0	1	0	0	1	Set the power save mode.

Note: The LCD power supply consists of a voltage multiplier (VC), a voltage regulator (VR), and a voltage follower (VF). Among these, the circuits set to operating state by the set power supply configuration command are turned off in the power save mode.

- Release Power Save Mode

Returns the driver (controller) from the power save mode. Circuits set to the operating state by the set supply configuration command only are turned on.

RS	R/W	D7	D6	D5	D4	D3	D2	D1	D0	Description
0	0	1	1	1	0	0	0	0	1	Release the power save mode.

- Start Internal Oscillator Circuit

This command activates the internal oscillator circuit. Note that since the oscillator circuit stops operation after the reset using the $\overline{\text{RESET}}$ pin, this instruction must be executed for initialization.

RS	R/W	D7	D6	D5	D4	D3	D2	D1	D0	Description
0	0	1	0	1	0	1	0	1	1	Start internal oscillation circuit.

- Display On/Off

Turns the display on and off without modifying the display data RAM content. (0: off, 1: on) This command has priority over Light All Dots and Reverse Display On/Off commands. Commands are accepted while the display is off, but the visual state of the display does not change.

RS	R/W	D7	D6	D5	D4	D3	D2	D1	D0	Description
0	0	1	0	1	0	1	1	1	D10	Display On/Off

- Reset

Resets some functions of the driver/controller. See Reset Section below for more details.

RS	R/W	D7	D6	D5	D4	D3	D2	D1	D0	Description
0	0	1	1	1	0	0	0	1	0	Reset

- Set Display Data Length (2-byte instruction)

This command is used in the 3-line serial interface mode (without RS signal). The specified number (1 to 256) of data bytes that continue after this set display data length command are processed as a display data. And a command that is input after the transmission of the display data is regarded as a command data.

One pixel data consists of 2 bits. Set the display data length to even byte although odd byte setting also is possible. This is because writing from the 2nd byte of each pixel cannot be started.

This command is ignored (NOOP) in the 4-line serial interface mode and 4-line parallel interface mode.

RS	R/W	D7	D6	D5	D4	D3	D2	D1	D0	Description
0	0	1	1	1	0	1	0	0	0	Set the display data length.
0	0	D7	D6	D5	D4	D3	D2	D1	D0	

Note: Make sure to input the upper instruction before inputting the lower instruction.

D7	D6	D5	D4	D3	D2	D1	D0	Display data length
0	0	0	0	0	0	0	0	1
0	0	0	0	0	0	0	1	2
0	0	0	0	0	0	1	0	3
:	:	:	:	:	:	:	:	:
1	1	1	1	1	1	0	1	254
1	1	1	1	1	1	1	0	255
1	1	1	1	1	1	1	1	256

- Set FRC/PWM Mode

Sets the pulse width (PWM) and frame cycle (FRC) for gray-scale operation.

RS	R/W	D7	D6	D5	D4	D3	D2	D1	D0	Description
0	0	1	0	0	1	0	FRC	PWM1	PWM0	Set PWM and FRC mode

FRC
 0: 4-frame
 1: 3-frame

PWM1, PWM0
 00: 9-level
 01: 9-level
 10: 12-level
 11: 15-level

- Set Gray Scale Register (2-byte instruction)

This instruction is used for setting the PWM pulse width, frame-by-frame, corresponding to the 4-level gradation. For details on the operation of the register setting, refer to Tables 7 and 8.

RS	R/W	D7	D6	D5	D4	D3	D2	D1	D0	Description
0	0	1	0	0	0	1	0	0	0	Set white pulse width, 1/2.
0	0	WB3	WB2	WB1	WB0	WA3	WA2	WA1	WA0	
0	0	1	0	0	0	1	0	0	1	Set white pulse width, 3/4.
0	0	WD3	WD2	WD1	WD0	WC3	WC2	WC1	WC0	
0	0	1	0	0	0	1	0	1	0	Set light gray pulse width, 1/2.
0	0	LB3	LB2	LB1	LB0	LA3	LA2	LA1	LA0	
0	0	1	0	0	0	1	0	1	1	Set light gray pulse width, 3/4.
0	0	LD3	LD2	LD1	LD0	LC3	LC2	LC1	LC0	
0	0	1	0	0	0	1	1	0	0	Set dark gray pulse width, 1/2.
0	0	DB3	DB2	DB1	DB0	DA3	DA2	DA1	DA0	
0	0	1	0	0	0	1	1	0	1	Set dark gray pulse width, 3/4.
0	0	DD3	DD2	DD1	DD0	DC3	DC2	DC1	DC0	
0	0	1	0	0	0	1	1	1	0	Set black pulse width, 1/2.
0	0	BB3	BB2	BB1	BB0	BA3	BA2	BA1	BA0	
0	0	1	0	0	0	1	1	1	1	Set black pulse width, 3/4.
0	0	BD3	BD2	BD1	BD0	BC3	BC2	BC1	BC0	

WA3–WA0, LA3–LA0, DA3–DA0, BA3–BA0: First frame pulse width
 WB3–WB0, LB3–LB0, DB3–DB0, BB3–BB0: Second frame pulse width
 WC3–WC0, LC3–LC0, DC3–DC0, BC3–BC0: Third frame pulse width
 WD3–WD0, LD3–LD0, DD3–DD0, BD3–BD0: Fourth frame pulse width
 The 4th frame data is “don’t care” in 3-frame FRC.

Note: Make sure to input the upper instruction before inputting the lower instruction.

- Test Instruction for Supplier Exclusive Use

RS	R/W	D7	D6	D5	D4	D3	D2	D1	D0	Description
0	0	1	1	1	1	x	x	x	x	Test instruction for supplier exclusive use

This command is reserved for the test by the manufacturer – DO NOT USE!

Reset Defaults

Reset includes a hardware reset by $\overline{\text{RESET}}$ pin and software reset by the reset command. When the ML9055A is powered, the hardware reset by $\overline{\text{RESET}}$ pin must be performed prior to executing any other instructions.

O: Initialization executed. —: No change

Item	Parameter	Initial value after reset	Hardware	Software	Remarks
Set column address (lower)	(C3, C2, C1, C0)	(0, 0, 0, 0)	O	O	
Set column address (upper)	(C6, C5, C4)	(0, 0, 0)	O	O	
Set page address	(P3, P2, P1, P0)	(0, 0, 0, 0)	O	O	
Set internal resistance ratio	(R2, R1, R0)	(0, 0, 0)	O	O	2.3 times
Set power supply configuration	(VC, VR, VF)	(0, 0, 0)	O	—	Voltage multiplier, regulator, and VF amp. are all off.
Set scan start COM	(L6, L5, L4, L3, L2, L1, L0)	(0, 0, 0, 0, 0, 0, 0)	O	O	
Set initial display line address	(C6, C5, C4, C3, C2, C1, C0)	(0, 0, 0, 0, 0, 0, 0)	O	—	
Set number of display lines	(D7, D6, D5, D4, D3, D2, D1, D0)	(1, 0, 0, 0, 0, 0, 0, 0)	O	—	128 lines
Set N-line inversion	(N4, N3, N2, N1, N0)	(0, 0, 0, 0, 0)	O	—	Frame inversion
Set LCD bias ratio	(BI2, BI1, BI0)	(1, 1, 1)	O	—	1/12 bias
Set voltage multiplication	(BO1, BO0)	(0, 0)	O	—	3 times
Set contrast	(C5, C4, C3, C2, C1, C0)	(1, 0, 0, 0, 0, 0)	O	O	32
ADC select	S0	0	O	—	RAM address i corresponds to SEGi.
Set COM scan direction	SC0	0	O	—	COM0→COM127
Light all dots	E0	0	O	—	Normal display
Reverse display on/off	R0	0	O	—	Normal display
Set power save mode	—	Release	O	—	
Display on/off	DI0	0	O	—	Off
Set display data length	(D7, D6, D5, D4, D3, D2, D1, D0)	(0, 0, 0, 0, 0, 0, 0, 0)	O	O	1 byte
Set FRC/PWM mode	(FRC, PWM1, PWM0)	(0, 0, 0)	O	O	4-frame, 9-level
Set white pulse width, 1/2	(WB3, WB2, WB1, WB0, WA3, WA2, WA1, WA0)	(0, 0, 0, 0, 0, 0, 0, 0)	O	O	
Set white pulse width, 3/4	(WD3, WD2, WD1, WD0, WC3, WC2, WC1, WC0)	(0, 0, 0, 0, 0, 0, 0, 0)	O	O	
Set light gray pulse width, 1/2	(LB3, LB2, LB1, LB0, LA3, LA2, LA1, LA0)	(0, 0, 0, 0, 0, 0, 0, 0)	O	O	
Set light gray pulse width, 3/4	(LD3, LD2, LD1, LD0, LC3, LC2, LC1, LC0)	(0, 0, 0, 0, 0, 0, 0, 0)	O	O	
Set dark gray pulse width, 1/2	(DB3, DB2, DB1, DB0, DA3, DA2, DA1, DA0)	(1, 1, 1, 1, 1, 1, 1, 1)	O	O	
Set dark gray pulse width, 3/4	(DD3, DD2, DD1, DD0, DC3, DC2, DC1, DC0)	(1, 1, 1, 1, 1, 1, 1, 1)	O	O	
Set black pulse width, 1/2	(BB3, BB2, BB1, BB0, BA3, BA2, BA1, BA0)	(1, 1, 1, 1, 1, 1, 1, 1)	O	O	
Set black pulse width, 3/4	(BD3, BD2, BD1, BD0, BC3, BC2, BC1, BC0)	(1, 1, 1, 1, 1, 1, 1, 1)	O	O	
Oscillator circuit	—	OFF	O	—	Internal oscillator circuit stops operation.

OPERATING SEQUENCE

Power-on Sequence in Using the Built-in Power Supply Circuits

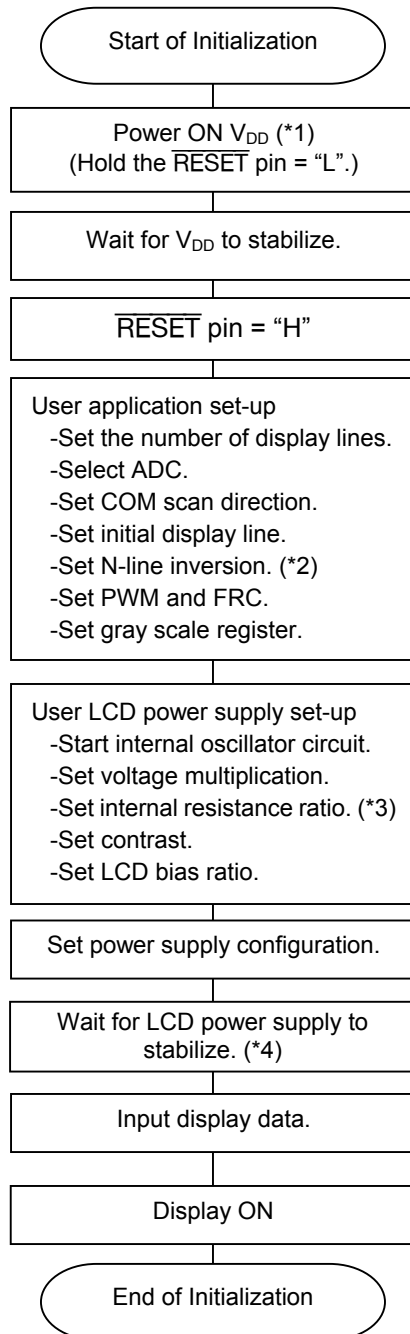

(*1): Apply VCI also simultaneously with V_{DD} .

(*2): Only when line inversion is used. When using frame inversion, either release N-line inversion or specify 0 lines.

(*3): Only when using the internal resistors.

(*4): The stabilizing time primarily depends on factors such as the voltage multiplier setting, the internal resistance ratio, and the external capacitors.

Power-on Sequence in Using an External Power Supply Circuit

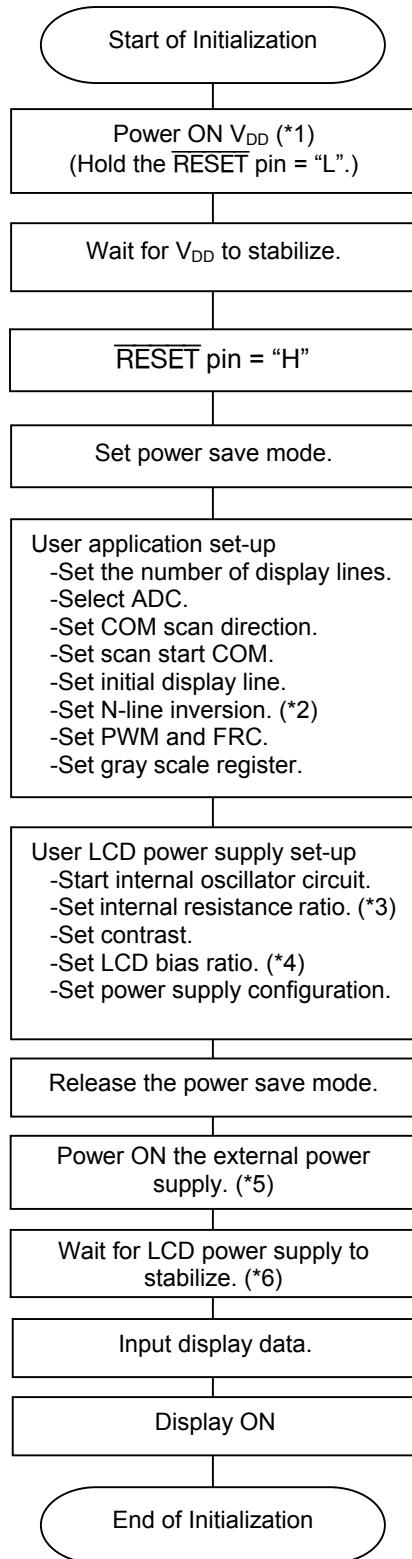

- (*1): Apply VCI also simultaneously with V_{DD}.
- (*2): Only when line inversion is used. When using the frame inversion, either release N-line inversion or specify 0 lines.
- (*3): Only when using the internal resistors.
- (*4): Only when using the voltage follower.
- (*5): Input sequentially external power supplies from the one with higher potential.
- (*6): The stabilizing time primarily depends on factors such as the internal resistance ratio, and the external capacitors.

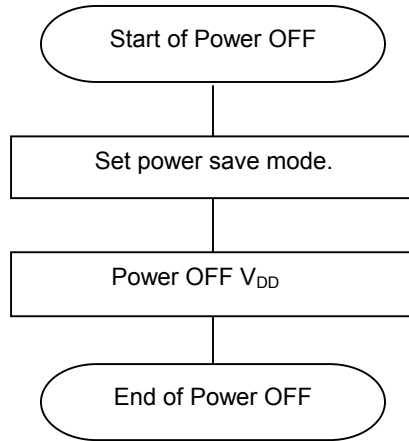
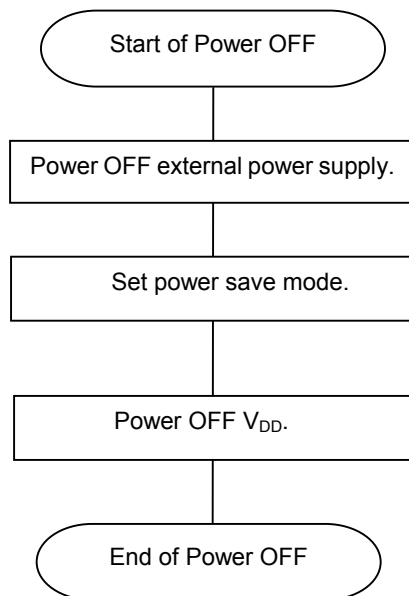
Power off Sequence in Using a Built-in Power Supply**Power off Sequence in Using an External Power Supply**

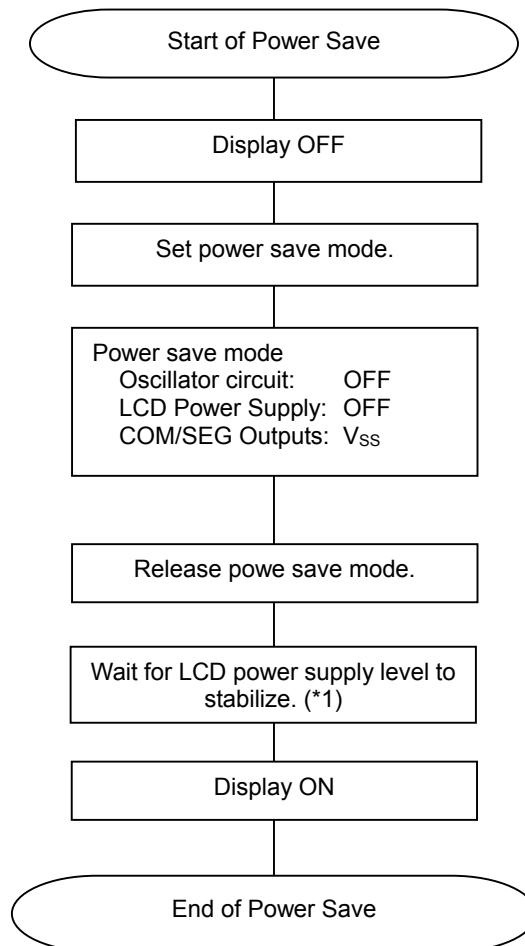
Start and End of Power Save Sequence in Using a Built-in Power Supply

(*1) The stabilized time depends on the voltage multiplier setting, the internal resistance ratio, the external capacitors, and so on.

Start and End of Power Save Sequence in Using an External Power Supply

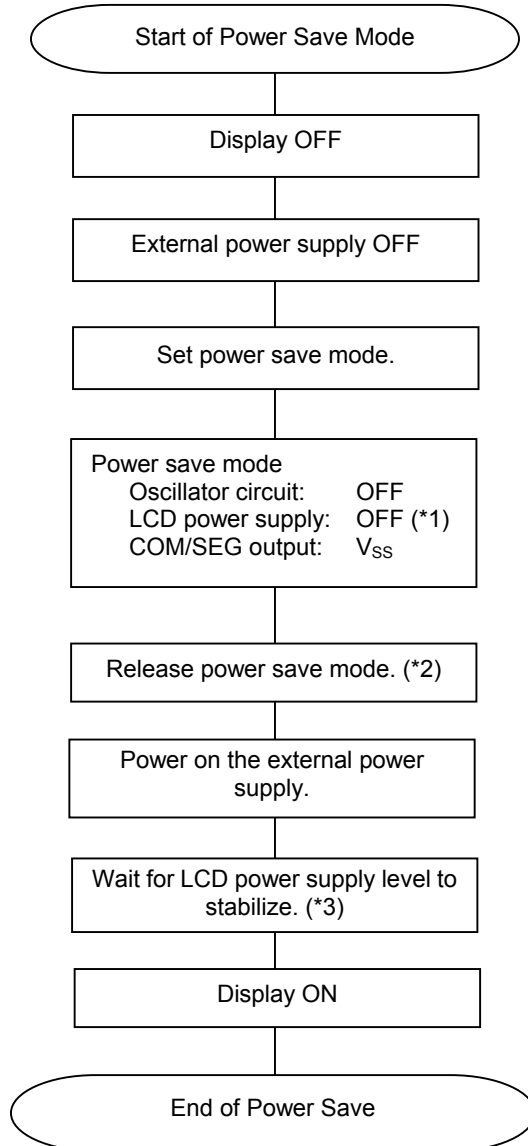

(*1): Turns off the circuits set to operating state by the set power supply configuration instruction.

(*2): The LCD power supplies set to the operating state only are turned on by the set power supply configuration instruction.

(*3): The stabilizing time primarily depends on factors such as the voltage multiplier setting, the internal resistance ratio, and the external capacitors.

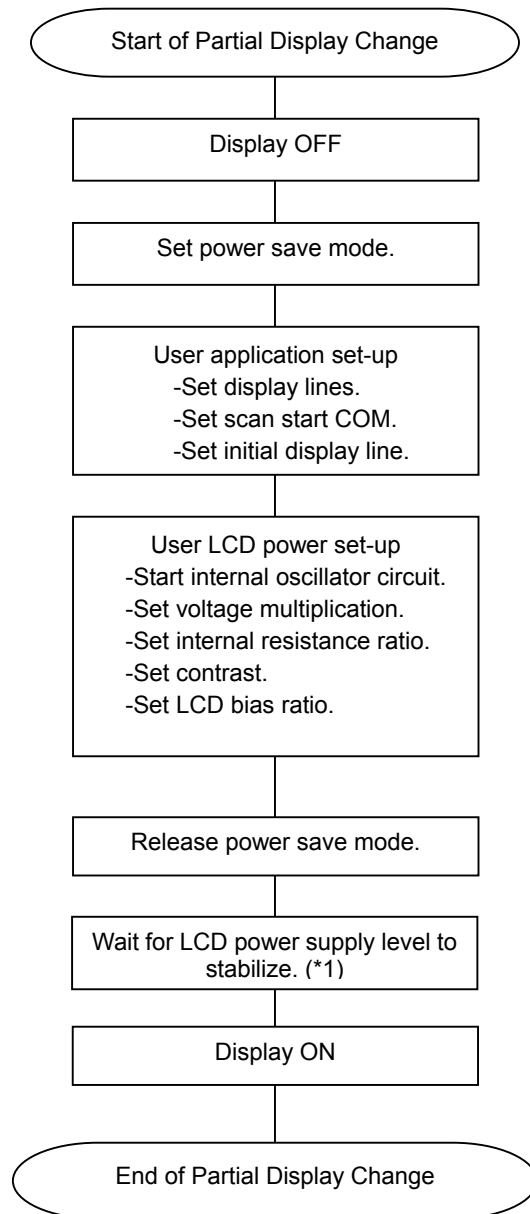
Partial Display Change Sequence in Using a Built-in Power Supply

(*1) The stabilized time depends on the voltage multiplier setting, the internal resistance ratio, the external capacitors, and so on.

Partial Display Chang Sequence in Using an External Power Supply

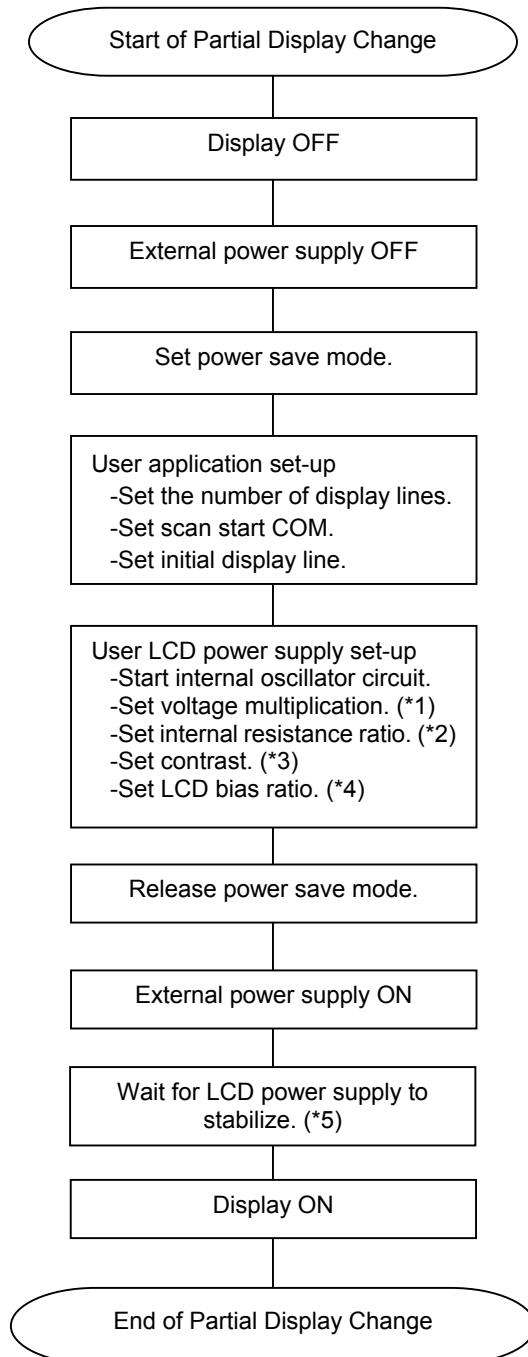

(*1). Only when using the built-in voltage multiplier.

(*2). Only when using the internal resistors.

(*3). Only when using the built-in voltage regulator.

(*4). Only when using the built-in voltage follower.

(*5). The stabilizing time primarily depends on factors such as the voltage multiplier, the internal resistance ratio, and the external capacitors.

Display Data Write Sequence

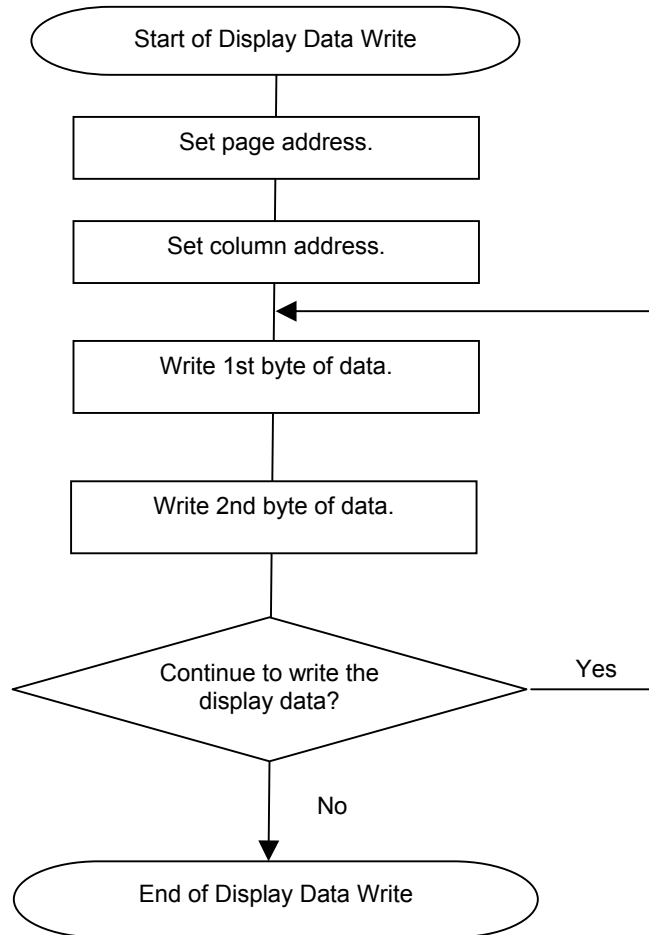

Display Data Read Sequence

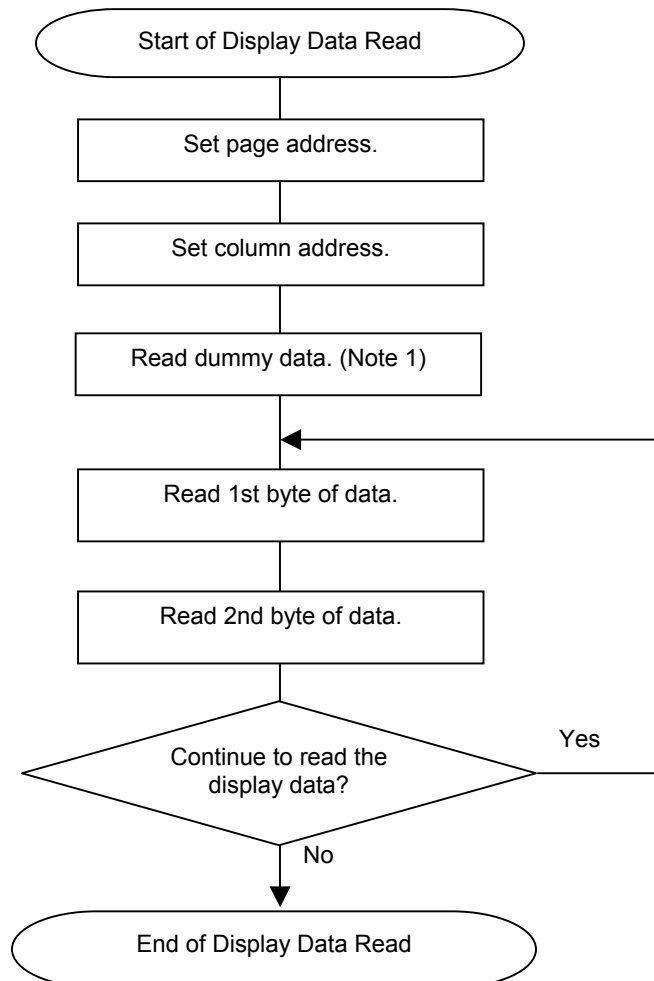

Note 1: Although the display RAM data is of 2 bytes, the dummy data is read once (1 byte) only.

Note 2: The trace impedance (specially, the V_{DD} , V_{SS} , VCI impedance and the data bus trace capacitance etc.) between this chip and circuit board should be designed as low as possible. Factors such as not sufficiently low trace impedance, LCD panel of large size, and higher trace impedance of the microcomputer interface, would become a cause of the ML9055A malfunction. In such a situation, use the microcomputer interface not for reading, but for writing only to reduce the power supply noise.

Read Modify Write Sequence

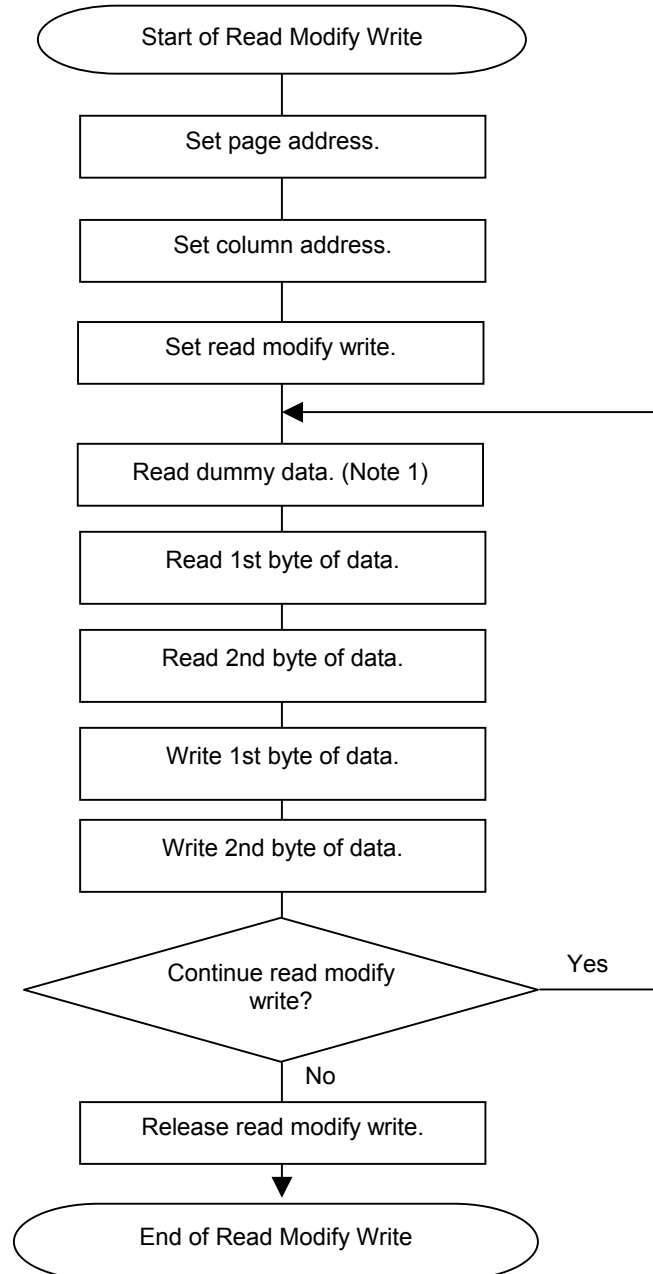

Note 1: Although the display RAM data is of 2 bytes, the dummy data is read once (1 byte) only.

Note 2: In the case of the read modify write operation, it is necessary to read dummy data for every read operation.

Note 3: The trace impedance (specially, the V_{DD} , V_{SS} , VCI impedance and the data bus trace capacitance etc.) between this chip and circuit board should be designed as low as possible. Factors such as not sufficiently low trace impedance, LCD panel of large size, and high trace impedance of the microcomputer interface, would become a cause of the ML9055A malfunction. In such a situation, use the microcomputer interface not for reading, but for writing only to reduce the power supply noise.

PAD CONFIGURATION

Pad Layout

Chip Size: 9.28mm × 3.95 mm

Chip Thickness: 625±15 μm

Bump Size (1): 70 × 70 μm
(PAD No. 1-100)

Bump Size (2): 70 × 37 μm
(PAD No. 101-369)

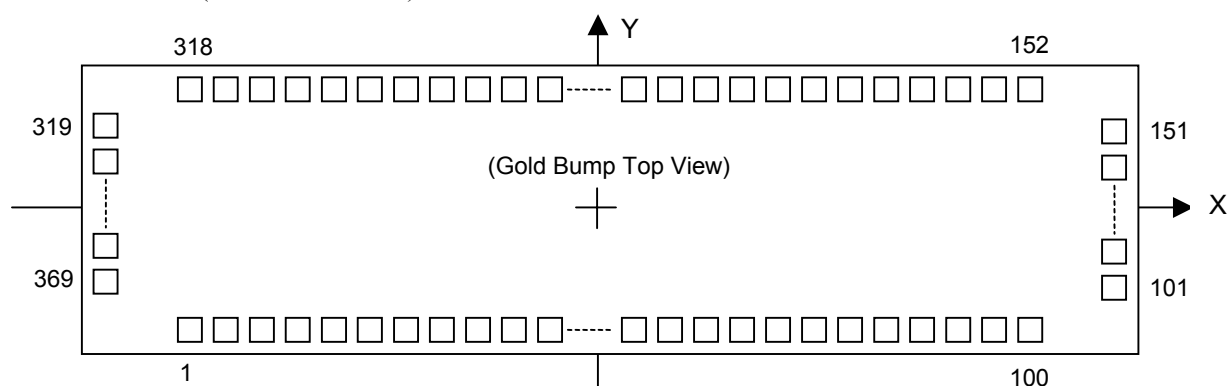

Pad Coordinates

Pad No.	Pad Name	X (μm)	Y (μm)	Pad No.	Pad Name	X (μm)	Y (μm)
1	DUMMY	-4270	-1843	34	V _{DD}	-1465	-1843
2	DUMMY	-4185	-1843	35	V _{DD}	-1380	-1843
3	DUMMY	-4100	-1843	36	V _{DD}	-1295	-1843
4	DUMMY	-4015	-1843	37	V _{DD}	-1210	-1843
5	DUMMY	-3930	-1843	38	V _{DD}	-1125	-1843
6	DUMMY	-3845	-1843	39	V _{CI}	-1040	-1843
7	DUMMY	-3760	-1843	40	V _{CI}	-955	-1843
8	DUMMY-B	-3675	-1843	41	V _{SS}	-870	-1843
9	DUMMY-B	-3590	-1843	42	V _{SS}	-785	-1843
10	V _{DD}	-3505	-1843	43	V _{SS}	-700	-1843
11	TEST2	-3420	-1843	44	V _{SS}	-615	-1843
12	V _{SS}	-3335	-1843	45	V _{SS}	-530	-1843
13	PS0	-3250	-1843	46	V _{SS}	-445	-1843
14	V _{DD}	-3165	-1843	47	V _{SS}	-360	-1843
15	PS1	-3080	-1843	48	V _{OUT}	-275	-1843
16	V _{SS}	-2995	-1843	49	V _{OUT}	-190	-1843
17	CS	-2910	-1843	50	C5+	-105	-1843
18	RESET	-2825	-1843	51	C5+	-20	-1843
19	V _{DD}	-2740	-1843	52	C3+	65	-1843
20	RS	-2655	-1843	53	C3+	150	-1843
21	R/W (WR)	-2570	-1843	54	C1-	235	-1843
22	V _{SS}	-2485	-1843	55	C1-	320	-1843
23	E (RD)	-2400	-1843	56	C1+	405	-1843
24	V _{DD}	-2315	-1843	57	C1+	490	-1843
25	DB0	-2230	-1843	58	C2+	575	-1843
26	DB1	-2145	-1843	59	C2+	660	-1843
27	DB2	-2060	-1843	60	C2-	745	-1843
28	DB3	-1975	-1843	61	C2-	830	-1843
29	DB4	-1890	-1843	62	C4+	915	-1843
30	DB5	-1805	-1843	63	C4+	1000	-1843
31	DB6	-1720	-1843	64	V _{DD}	1085	-1843
32	DB7	-1635	-1843	65	V _{DD}	1170	-1843
33	V _{DD}	-1550	-1843	66	REF	1255	-1843

Pad No.	Pad Name	X (μm)	Y (μm)	Pad No.	Pad Name	X (μm)	Y (μm)
67	V _{SS}	1340	-1843	128	COM38	4509	-223
68	VEXT	1425	-1843	129	COM37	4509	-171
69	V _{DD}	1510	-1843	130	COM36	4509	-119
70	INTRS	1595	-1843	131	COM35	4509	-67
71	V _{SS}	1680	-1843	132	COM34	4509	-15
72	V _{SS}	1765	-1843	133	COM33	4509	37
73	V4	1850	-1843	134	COM32	4509	89
74	V4	1935	-1843	135	COM31	4509	141
75	V3	2020	-1843	136	COM30	4509	193
76	V3	2105	-1843	137	COM29	4509	245
77	V2	2190	-1843	138	COM28	4509	297
78	V2	2275	-1843	139	COM27	4509	349
79	V1	2360	-1843	140	COM26	4509	401
80	V1	2445	-1843	141	COM25	4509	453
81	V0	2530	-1843	142	COM24	4509	505
82	V0	2615	-1843	143	COM23	4509	557
83	VR	2700	-1843	144	COM22	4509	609
84	VR	2785	-1843	145	COM21	4509	661
85	V _{SS}	2870	-1843	146	COM20	4509	713
86	V _{SS}	2955	-1843	147	COM19	4509	765
87	V _{DD}	3040	-1843	148	COM18	4509	817
88	TEST1	3125	-1843	149	COM17	4509	869
89	DUMMY-B	3210	-1843	150	COM16	4509	921
90	DUMMY-B	3295	-1843	151	DUMMY	4509	1619
91	DUMMY-B	3380	-1843	152	DUMMY	4342	1843
92	DUMMY-B	3465	-1843	153	DUMMY	4290	1843
93	DUMMY-B	3550	-1843	154	COM15	4238	1843
94	DUMMY-B	3635	-1843	155	COM14	4186	1843
95	DUMMY-B	3720	-1843	156	COM13	4134	1843
96	DUMMY-B	3805	-1843	157	COM12	4082	1843
97	DUMMY-B	3890	-1843	158	COM11	4030	1843
98	DUMMY-B	3975	-1843	159	COM10	3978	1843
99	DUMMY	4060	-1843	160	COM9	3926	1843
100	DUMMY	4145	-1843	161	COM8	3874	1843
101	DUMMY	4509	-1627	162	COM7	3822	1843
102	DUMMY	4509	-1575	163	COM6	3770	1843
103	COM63	4509	-1523	164	COM5	3718	1843
104	COM62	4509	-1471	165	COM4	3666	1843
105	COM61	4509	-1419	166	COM3	3614	1843
106	COM60	4509	-1367	167	COM2	3562	1843
107	COM59	4509	-1315	168	COM1	3510	1843
108	COM58	4509	-1263	169	COM0	3458	1843
109	COM57	4509	-1211	170	DUMMY	3354	1843
110	COM56	4509	-1159	171	DUMMY	3302	1843
111	COM55	4509	-1107	172	SEG0	3250	1843
112	COM54	4509	-1055	173	SEG1	3198	1843
113	COM53	4509	-1003	174	SEG2	3146	1843
114	COM52	4509	-951	175	SEG3	3094	1843
115	COM51	4509	-899	176	SEG4	3042	1843
116	COM50	4509	-847	177	SEG5	2990	1843
117	COM49	4509	-795	178	SEG6	2938	1843
118	COM48	4509	-743	179	SEG7	2886	1843
119	COM47	4509	-691	180	SEG8	2834	1843
120	COM46	4509	-639	181	SEG9	2782	1843
121	COM45	4509	-587	182	SEG10	2730	1843
122	COM44	4509	-535	183	SEG11	2678	1843
123	COM43	4509	-483	184	SEG12	2626	1843
124	COM42	4509	-431	185	SEG13	2574	1843
125	COM41	4509	-379	186	SEG14	2522	1843
126	COM40	4509	-327	187	SEG15	2470	1843
127	COM39	4509	-275	188	SEG16	2418	1843

Pad No.	Pad Name	X (μm)	Y (μm)	Pad No.	Pad Name	X (μm)	Y (μm)
189	SEG17	2366	1843	250	SEG78	-806	1843
190	SEG18	2314	1843	251	SEG79	-858	1843
191	SEG19	2262	1843	252	SEG80	-910	1843
192	SEG20	2210	1843	253	SEG81	-962	1843
193	SEG21	2158	1843	254	SEG82	-1014	1843
194	SEG22	2106	1843	255	SEG83	-1066	1843
195	SEG23	2054	1843	256	SEG84	-1118	1843
196	SEG24	2002	1843	257	SEG85	-1170	1843
197	SEG25	1950	1843	258	SEG86	-1222	1843
198	SEG26	1898	1843	259	SEG87	-1274	1843
199	SEG27	1846	1843	260	SEG88	-1326	1843
200	SEG28	1794	1843	261	SEG89	-1378	1843
201	SEG29	1742	1843	262	SEG90	-1430	1843
202	SEG30	1690	1843	263	SEG91	-1482	1843
203	SEG31	1638	1843	264	SEG92	-1534	1843
204	SEG32	1586	1843	265	SEG93	-1586	1843
205	SEG33	1534	1843	266	SEG94	-1638	1843
206	SEG34	1482	1843	267	SEG95	-1690	1843
207	SEG35	1430	1843	268	SEG96	-1742	1843
208	SEG36	1378	1843	269	SEG97	-1794	1843
209	SEG37	1326	1843	270	SEG98	-1846	1843
210	SEG38	1274	1843	271	SEG99	-1898	1843
211	SEG39	1222	1843	272	SEG100	-1950	1843
212	SEG40	1170	1843	273	SEG101	-2002	1843
213	SEG41	1118	1843	274	SEG102	-2054	1843
214	SEG42	1066	1843	275	SEG103	-2106	1843
215	SEG43	1014	1843	276	SEG104	-2158	1843
216	SEG44	962	1843	277	SEG105	-2210	1843
217	SEG45	910	1843	278	SEG106	-2262	1843
218	SEG46	858	1843	279	SEG107	-2314	1843
219	SEG47	806	1843	280	SEG108	-2366	1843
220	SEG48	754	1843	281	SEG109	-2418	1843
221	SEG49	702	1843	282	SEG110	-2470	1843
222	SEG50	650	1843	283	SEG111	-2522	1843
223	SEG51	598	1843	284	SEG112	-2574	1843
224	SEG52	546	1843	285	SEG113	-2626	1843
225	SEG53	494	1843	286	SEG114	-2678	1843
226	SEG54	442	1843	287	SEG115	-2730	1843
227	SEG55	390	1843	288	SEG116	-2782	1843
228	SEG56	338	1843	289	SEG117	-2834	1843
229	SEG57	286	1843	290	SEG118	-2886	1843
230	SEG58	234	1843	291	SEG119	-2938	1843
231	SEG59	182	1843	292	SEG120	-2990	1843
232	SEG60	130	1843	293	SEG121	-3042	1843
233	SEG61	78	1843	294	SEG122	-3094	1843
234	SEG62	26	1843	295	SEG123	-3146	1843
235	SEG63	-26	1843	296	SEG124	-3198	1843
236	SEG64	-78	1843	297	SEG125	-3250	1843
237	SEG65	-130	1843	298	SEG126	-3302	1843
238	SEG66	-182	1843	299	SEG127	-3354	1843
239	SEG67	-234	1843	300	DUMMY	-3406	1843
240	SEG68	-286	1843	301	COM64	-3458	1843
241	SEG69	-338	1843	302	COM65	-3510	1843
242	SEG70	-390	1843	303	COM66	-3562	1843
243	SEG71	-442	1843	304	COM67	-3614	1843
244	SEG72	-494	1843	305	COM68	-3666	1843
245	SEG73	-546	1843	306	COM69	-3718	1843
246	SEG74	-598	1843	307	COM70	-3770	1843
247	SEG75	-650	1843	308	COM71	-3822	1843
248	SEG76	-702	1843	309	COM72	-3874	1843
249	SEG77	-754	1843	310	COM73	-3926	1843

Pad No.	Pad Name	X (μm)	Y (μm)	Pad No.	Pad Name	X (μm)	Y (μm)
311	COM74	-3978	1843	341	COM101	-4509	-171
312	COM75	-4030	1843	342	COM102	-4509	-223
313	COM76	-4082	1843	343	COM103	-4509	-275
314	COM77	-4134	1843	344	COM104	-4509	-327
315	COM78	-4186	1843	345	COM105	-4509	-379
316	COM79	-4238	1843	346	COM106	-4509	-431
317	DUMMY	-4290	1843	347	COM107	-4509	-483
318	DUMMY	-4342	1843	348	COM108	-4509	-535
319	DUMMY	-4509	1619	349	COM109	-4509	-587
320	COM80	-4509	921	350	COM110	-4509	-639
321	COM81	-4509	869	351	COM111	-4509	-691
322	COM82	-4509	817	352	COM112	-4509	-743
323	COM83	-4509	765	353	COM113	-4509	-795
324	COM84	-4509	713	354	COM114	-4509	-847
325	COM85	-4509	661	355	COM115	-4509	-899
326	COM86	-4509	609	356	COM116	-4509	-951
327	COM87	-4509	557	357	COM117	-4509	-1003
328	COM88	-4509	505	358	COM118	-4509	-1055
329	COM89	-4509	453	359	COM119	-4509	-1107
330	COM90	-4509	401	360	COM120	-4509	-1159
331	COM91	-4509	349	361	COM121	-4509	-1211
332	COM92	-4509	297	362	COM122	-4509	-1263
333	COM93	-4509	245	363	COM123	-4509	-1315
334	COM94	-4509	193	364	COM124	-4509	-1367
335	COM95	-4509	141	365	COM125	-4509	-1419
336	COM96	-4509	89	366	COM126	-4509	-1471
337	COM97	-4509	37	367	COM127	-4509	-1523
338	COM98	-4509	-15	368	DUMMY	-4509	-1575
339	COM99	-4509	-67	369	DUMMY	-4509	-1627
340	COM100	-4509	-119				

(Note): Leave DUMMY-B pads open.

Do not run trace or do not share them with other DUMMY pads and DUMMY-B pads.

ML9055A ALIGNMENT MARK SPECIFICATION

Alignment Mark Coordinates

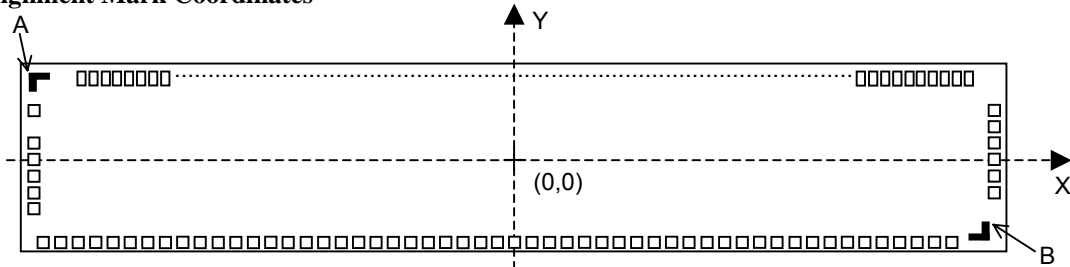

Alignment Mark	X Coordinate (μm)	Y Coordinate (μm)
A	-4509	1843
B	4509	-1843

Alignment Mark Layer

Bump layers

Alignment Mark Specification

Symbol	Parameter	Mark	Size (μm)
a	Alignment Mark Width	—	43
b	Alignment Mark Size	—	98
c	Minimum distance between Mark and Adjacent Pad Bump	Mark A	85.8
		Mark B	134.7

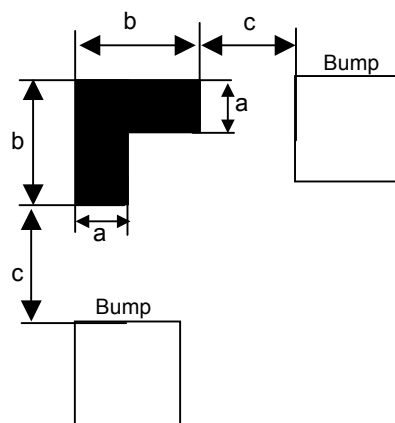

ML9055ADVX GOLD BUMP SPECIFICATION

(Low hardness product)

Gold Bump Specification

(Unit: μm)

Symbol	Parameter	MIN.	TYP.	MAX.
A	Bump Pitch (Min. Section: Output Section)	52	---	---
B	Bump Size (Output Section: Pitch Direction)	32	37	42
C	Bump Size (Output Section: Depth Direction)	65	70	75
D	Bump-to-Bump Distance (Output Section: Pitch Direction)	10	15	20
E	Bump Size (Input Section: Pitch Direction)	65	70	75
F	Bump Size (Input Section: Depth Direction)	65	70	75
G	Bump-to-Bump Distance (Input Section: Pitch Direction)	10	15	20
H	Bump Size ("L" Alignment Mark: Length)	93	98	103
I	Bump Size ("L" Alignment Mark: Width)	38	43	48
J	Tolerance between Pad and Bump Centers	---	---	2
K	Bump Height	10	15	20
	Bump Height Dispersion Inside Chip (Range)	---	---	3
L	Bump Edge Height	---	---	5
M	Shear Strength (g)	18	---	---
N	Bump Hardness (Hv: 25 g load)	30	---	80

Chip Thickness: $625 \pm 15 \mu\text{m}$
 Chip Size: $9.28 \text{ mm} \times 3.95 \text{ mm}$

Top View and Cross Section View

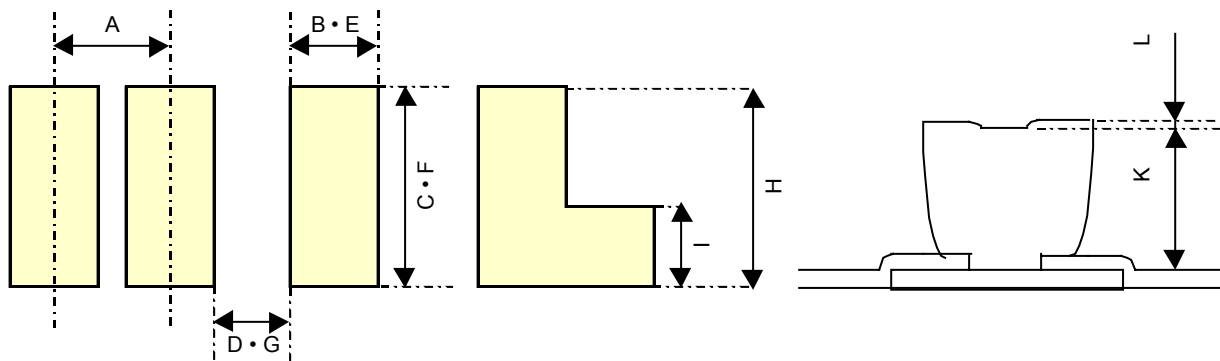

Input and Output Sections

"L" Alignment Mark

Cross Section View

REVISION HISTORY

Document No.	Date	Page		Description
		Previous Edition	Current Edition	
PEDL9055A-02-01	Jul. 26, 2002	–	–	Preliminary first edition

NOTICE

1. The information contained herein can change without notice owing to product and/or technical improvements. Before using the product, please make sure that the information being referred to is up-to-date.
2. The outline of action and examples for application circuits described herein have been chosen as an explanation for the standard action and performance of the product. When planning to use the product, please ensure that the external conditions are reflected in the actual circuit, assembly, and program designs.
3. When designing your product, please use our product below the specified maximum ratings and within the specified operating ranges including, but not limited to, operating voltage, power dissipation, and operating temperature.
4. Oki assumes no responsibility or liability whatsoever for any failure or unusual or unexpected operation resulting from misuse, neglect, improper installation, repair, alteration or accident, improper handling, or unusual physical or electrical stress including, but not limited to, exposure to parameters beyond the specified maximum ratings or operation outside the specified operating range.
5. Neither indemnity against nor license of a third party's industrial and intellectual property right, etc. is granted by us in connection with the use of the product and/or the information and drawings contained herein. No responsibility is assumed by us for any infringement of a third party's right which may result from the use thereof.
6. The products listed in this document are intended for use in general electronics equipment for commercial applications (e.g., office automation, communication equipment, measurement equipment, consumer electronics, etc.). These products are not authorized for use in any system or application that requires special or enhanced quality and reliability characteristics nor in any system or application where the failure of such system or application may result in the loss or damage of property, or death or injury to humans. Such applications include, but are not limited to, traffic and automotive equipment, safety devices, aerospace equipment, nuclear power control, medical equipment, and life-support systems.
7. Certain products in this document may need government approval before they can be exported to particular countries. The purchaser assumes the responsibility of determining the legality of export of these products and will take appropriate and necessary steps at their own expense for these.
8. No part of the contents contained herein may be reprinted or reproduced without our prior permission.

Copyright 2002 Oki Electric Industry Co., Ltd.