

Heterojunction Bipolar Transistor Technology (InGaP HBT)

Broadband High Linearity Amplifier

The MMG3012NT1 is a General Purpose Amplifier that is internally input matched and internally output matched. It is designed for a broad range of Class A, small-signal, high linearity, general purpose applications. It is suitable for applications with frequencies from 0 to 6000 MHz such as Cellular, PCS, BWA, WLL, PHS, CATV, VHF, UHF, UMTS and general small-signal RF.

Features

- Frequency: 0 - 6000 MHz
- P1dB: 18.5 dBm @ 900 MHz
- Small-Signal Gain: 19 dB @ 900 MHz
- Third Order Output Intercept Point: 34 dBm @ 900 MHz
- Single 5 Volt Supply
- Internally Matched to 50 Ohms
- Low Cost SOT-89 Surface Mount Package
- Pb-Free and RoHS Compliant
- In Tape and Reel. T1 Suffix = 1000 Units per 12 mm, 7 inch Reel.

MMG3012NT1

**0 - 6000 MHz, 19 dB
18.5 dBm
InGaP HBT**

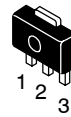

**CASE 1514-01, STYLE 1
SOT-89
PLASTIC**

Table 1. Typical Performance (1)

Characteristic	Symbol	900 MHz	2140 MHz	3500 MHz	Unit
Small-Signal Gain (S21)	G_p	19	15.8	13.4	dB
Input Return Loss (S11)	IRL	-18	-20	-17	dB
Output Return Loss (S22)	ORL	-18	-12	-16	dB
Power Output @1dB Compression	P1db	18.5	19	18	dBm
Third Order Output Intercept Point	IP3	34	32	31	dBm

1. $V_{CC} = 5$ Vdc, $T_C = 25^\circ\text{C}$, 50 ohm system

Table 2. Maximum Ratings

Rating	Symbol	Value	Unit
Supply Voltage (2)	V_{CC}	7	V
Supply Current (2)	I_{CC}	300	mA
RF Input Power	P_{in}	10	dBm
Storage Temperature Range	T_{stg}	-65 to +150	$^\circ\text{C}$
Junction Temperature (3)	T_J	150	$^\circ\text{C}$

2. Continuous voltage and current applied to device.

3. For reliable operation, the junction temperature should not exceed 150°C .

Table 3. Thermal Characteristics ($V_{CC} = 5$ Vdc, $I_{CC} = 70$ mA, $T_C = 25^\circ\text{C}$)

Characteristic	Symbol	Value (4)	Unit
Thermal Resistance, Junction to Case	$R_{\theta JC}$	85	$^\circ\text{C}/\text{W}$

4. Refer to AN1955, *Thermal Measurement Methodology of RF Power Amplifiers*. Go to <http://www.freescale.com/rf>. Select Documentation/Application Notes - AN1955.

Table 4. Electrical Characteristics ($V_{CC} = 5 \text{ Vdc}$, 900 MHz, $T_C = 25^\circ\text{C}$, 50 ohm system, in Freescale Application Circuit)

Characteristic	Symbol	Min	Typ	Max	Unit
Small-Signal Gain (S21)	G_p	17.5	19	—	dB
Input Return Loss (S11)	IRL	—	-18	—	dB
Output Return Loss (S22)	ORL	—	-18	—	dB
Power Output @ 1dB Compression	P1dB	—	18.5	—	dBm
Third Order Output Intercept Point	IP3	—	34	—	dBm
Noise Figure	NF	—	3.8	—	dB
Supply Current (1)	I_{CC}	58	70	82	mA
Supply Voltage (1)	V_{CC}	—	5	—	V

1. For reliable operation, the junction temperature should not exceed 150°C .

Table 5. Functional Pin Description

Pin Number	Pin Function
1	RF _{in}
2	Ground
3	RF _{out} /DC Supply

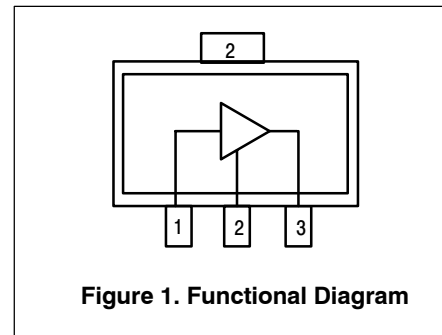
**Table 6. ESD Protection Characteristics**

Test Methodology	Class
Human Body Model (per JESD 22-A114)	1A (Minimum)
Machine Model (per EIA/JESD 22-A115)	A (Minimum)
Charge Device Model (per JESD 22-C101)	IV (Minimum)

Table 7. Moisture Sensitivity Level

Test Methodology	Rating	Package Peak Temperature	Unit
Per JESD 22-A113, IPC/JEDEC J-STD-020	1	260	°C

50 OHM TYPICAL CHARACTERISTICS

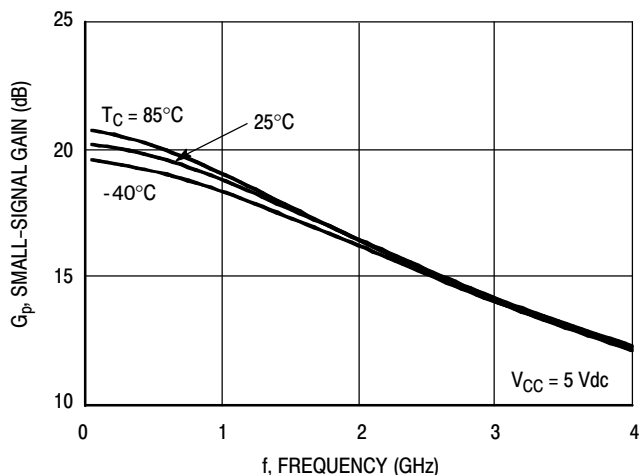

Figure 2. Small-Signal Gain (S21) versus Frequency

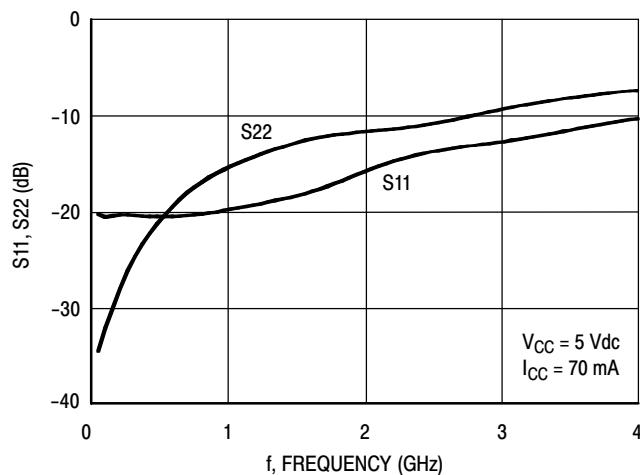

Figure 3. Input/Output Return Loss versus Frequency

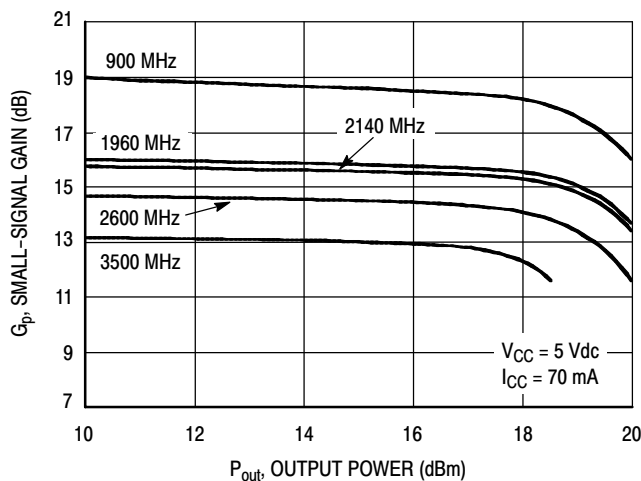

Figure 4. Small-Signal Gain versus Output Power

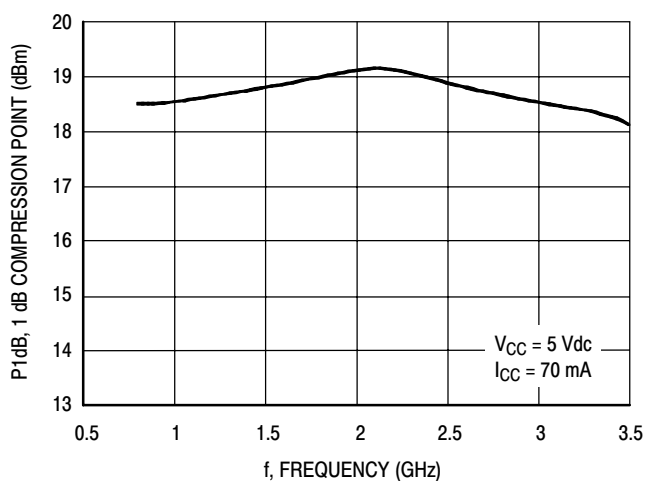

Figure 5. P1dB versus Frequency

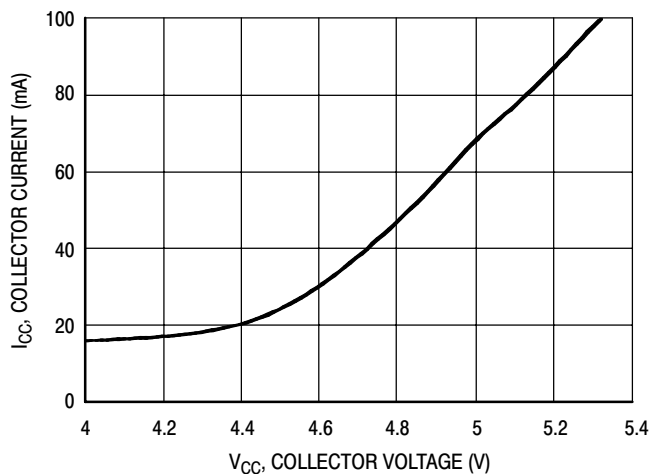

Figure 6. Collector Current versus Collector Voltage

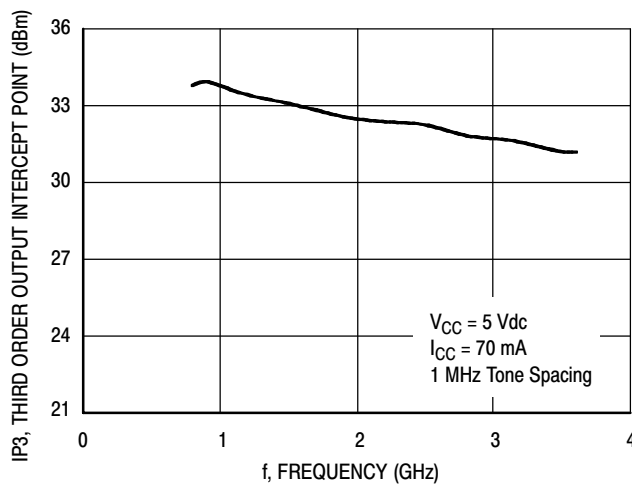

Figure 7. Third Order Output Intercept Point versus Frequency

50 OHM TYPICAL CHARACTERISTICS

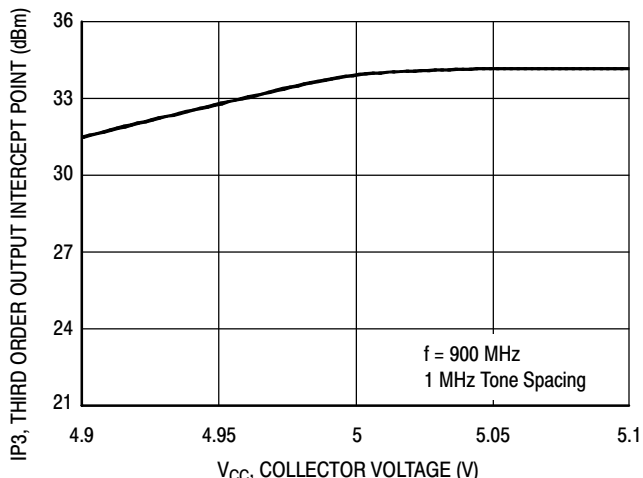

Figure 8. Third Order Output Intercept Point versus Collector Voltage

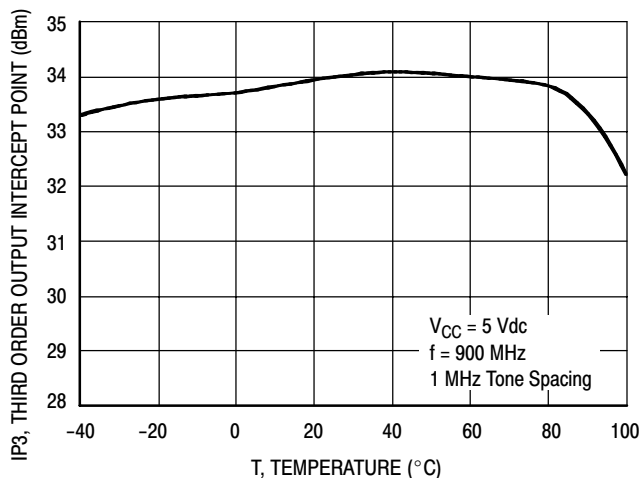

Figure 9. Third Order Output Intercept Point versus Case Temperature

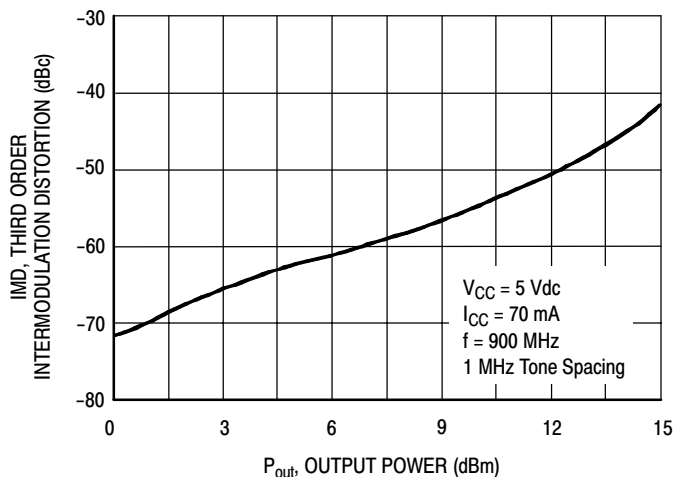
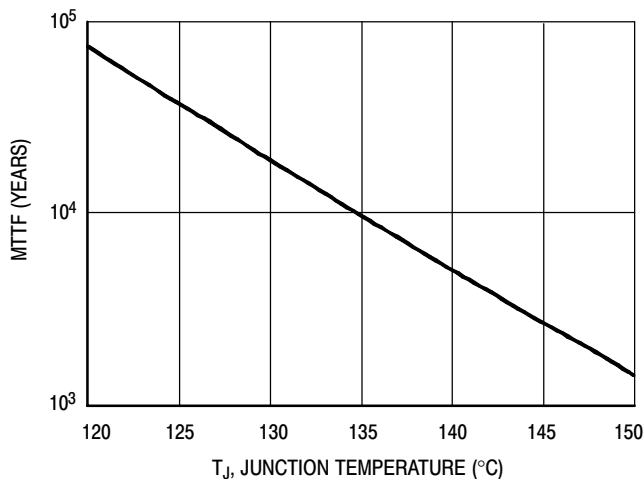

Figure 10. Third Order Intermodulation versus Output Power



NOTE: The MTTF is calculated with $V_{CC} = 5 \text{ Vdc}$, $I_{CC} = 70 \text{ mA}$

Figure 11. MTTF versus Junction Temperature

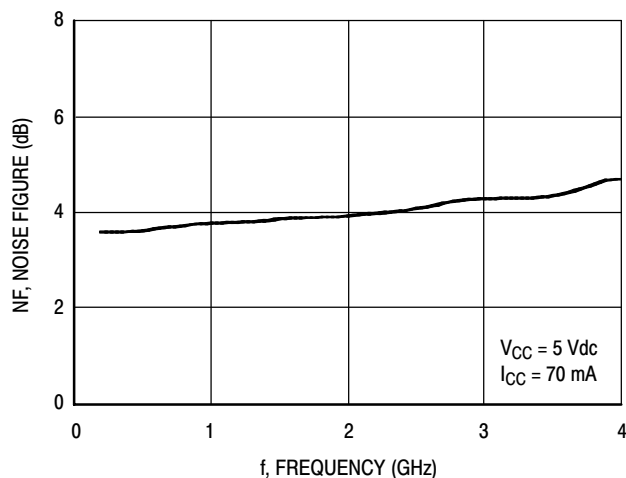

Figure 12. Noise Figure versus Frequency

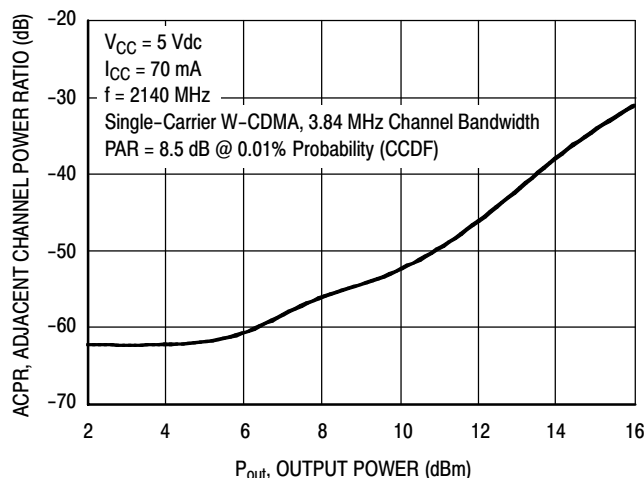

Figure 13. Single-Carrier W-CDMA Adjacent Channel Power Ratio versus Output Power

50 OHM APPLICATION CIRCUIT: 40-300 MHz

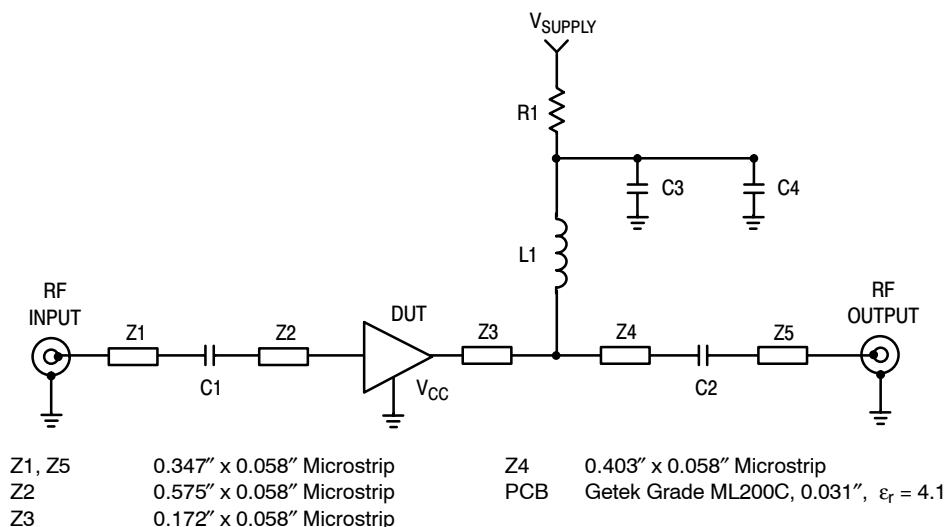

Figure 14. 50 Ohm Test Circuit Schematic

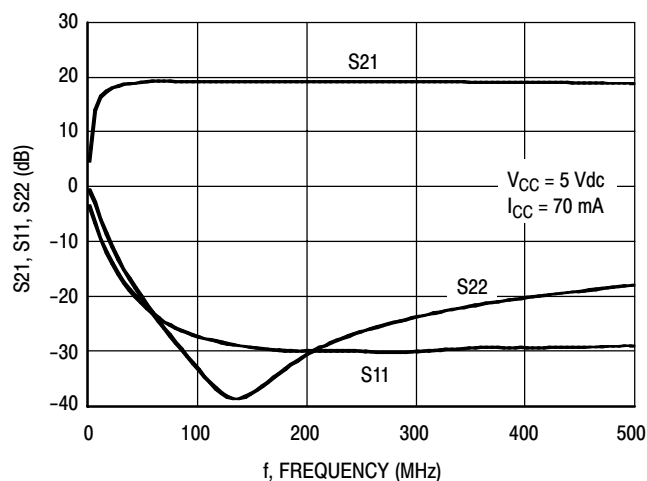

Figure 15. S21, S11 and S22 versus Frequency

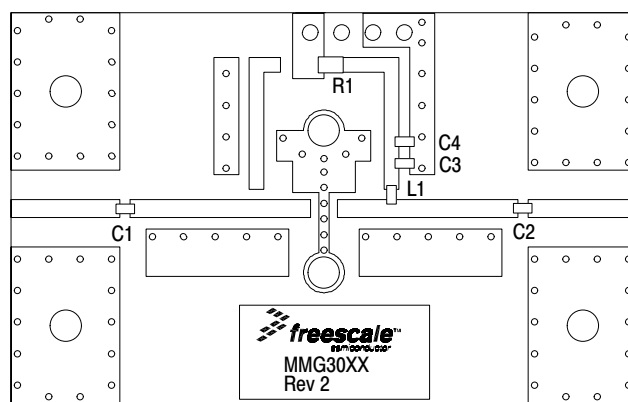

Figure 16. 50 Ohm Test Circuit Component Layout

Table 8. 50 Ohm Test Circuit Component Designations and Values

Part	Description	Part Number	Manufacturer
C1, C2, C3	0.01 μ F Chip Capacitors	0603A103JAT2A	AVX
C4	1000 pF Chip Capacitor	0603A102JAT2A	AVX
L1	470 nH Chip Inductor	BK2125HM471	Taiyo Yuden
R1	0 Ω Chip Resistor	ERJ3GEY0R00V	Panasonic

50 OHM APPLICATION CIRCUIT: 300-3600 MHz

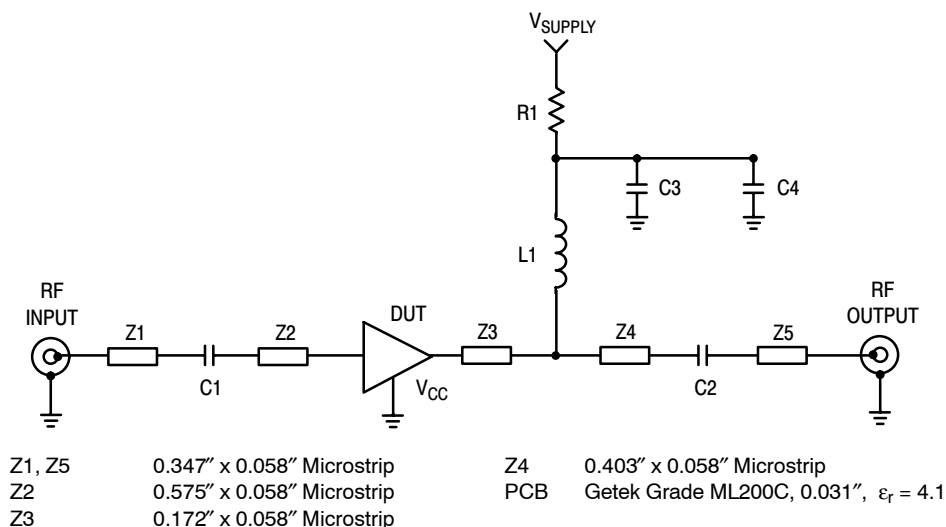

Figure 17. 50 Ohm Test Circuit Schematic

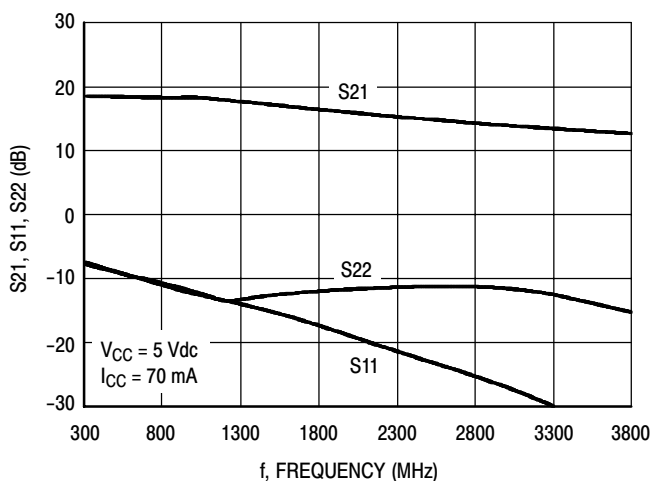

Figure 18. S21, S11 and S22 versus Frequency

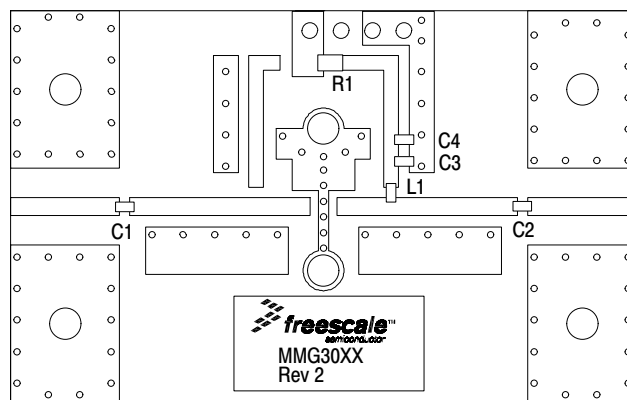

Figure 19. 50 Ohm Test Circuit Component Layout

Table 9. 50 Ohm Test Circuit Component Designations and Values

Part	Description	Part Number	Manufacturer
C1, C2	150 pF Chip Capacitors	06035A151JAT2A	AVX
C3	0.01 μ F Chip Capacitor	0603A103JAT2A	AVX
C4	1000 pF Chip Capacitor	0603A102JAT2A	AVX
L1	56 nH Chip Inductor	HK160856NJ-T	Taiyo Yuden
R1	0 Ω Chip Resistor	ERJ3GEY0R00V	Panasonic

50 OHM TYPICAL CHARACTERISTICS

Table 10. Class A Common Emitter S-Parameters at $V_{CC} = 5 \text{ Vdc}$, $I_{CC} = 70 \text{ mA}$, $T_C = 25^\circ\text{C}$

f GHz	S ₁₁		S ₂₁		S ₁₂		S ₂₂	
	S ₁₁	∠φ	S ₂₁	∠φ	S ₁₂	∠φ	S ₂₂	∠φ
0.1	0.09174	174.872	10.24140	174.57	0.07096	0.256	0.02426	-90.895
0.15	0.09324	173.141	10.19244	171.29	0.07214	-0.171	0.03097	-92.768
0.2	0.09550	172.602	10.14549	168.278	0.07255	-0.477	0.03654	-94.818
0.25	0.09721	171.41	10.09679	165.627	0.07316	-0.245	0.04935	-96.31
0.3	0.09703	170.357	10.03727	162.828	0.07333	-0.227	0.06092	-98.961
0.35	0.09452	169.626	9.99063	159.887	0.07362	-0.511	0.06932	-101.516
0.4	0.09430	168.366	9.92113	157.15	0.07387	-0.509	0.08063	-104.01
0.45	0.09343	167.117	9.84672	154.424	0.07402	-0.582	0.09043	-106.263
0.5	0.09237	166.034	9.77362	151.64	0.07435	-0.77	0.09911	-108.791
0.55	0.09271	164.864	9.68901	148.973	0.07457	-0.953	0.10788	-111.052
0.6	0.09245	163.824	9.60244	146.3	0.07487	-0.984	0.11655	-113.69
0.65	0.09228	162.689	9.51098	143.642	0.07531	-1.158	0.12425	-116.435
0.7	0.09283	161.228	9.41347	141.059	0.07577	-1.362	0.13246	-119.102
0.75	0.09352	159.955	9.31713	138.481	0.07608	-1.566	0.13942	-121.839
0.8	0.09460	158.511	9.21226	135.934	0.07652	-1.748	0.14612	-124.764
0.85	0.09591	157.224	9.10650	133.403	0.07698	-1.988	0.15280	-127.579
0.9	0.09731	155.828	9.00381	130.913	0.07747	-2.17	0.15946	-130.497
0.95	0.09918	154.356	8.89589	128.468	0.07786	-2.552	0.16560	-133.648
1	0.10165	153.21	8.79066	126.065	0.07831	-2.748	0.17180	-136.717
1.05	0.10456	151.519	8.67809	123.674	0.07892	-3.106	0.17724	-139.644
1.1	0.10530	150.349	8.55853	121.296	0.07939	-3.413	0.18362	-142.827
1.15	0.10595	149.493	8.43942	118.934	0.07997	-3.734	0.18945	-146.154
1.2	0.10816	148.216	8.32401	116.631	0.08032	-4.033	0.19501	-149.409
1.25	0.11046	147.031	8.21004	114.349	0.08086	-4.47	0.20058	-152.438
1.3	0.11249	145.868	8.10074	112.14	0.08142	-4.792	0.20635	-155.584
1.35	0.11403	144.558	7.98739	109.93	0.08202	-5.279	0.21190	-158.664
1.4	0.11488	143.211	7.87293	107.781	0.08247	-5.657	0.21733	-161.631
1.45	0.11602	142.244	7.75891	105.625	0.08302	-6.021	0.22271	-164.745
1.5	0.11686	136.948	7.66911	103.599	0.08384	-6.437	0.23416	-166.394
1.55	0.11834	134.929	7.55873	101.565	0.08447	-6.947	0.23853	-169.432
1.6	0.12187	132.851	7.45808	99.538	0.08501	-7.329	0.24236	-172.577
1.65	0.12645	130.925	7.35252	97.533	0.08565	-7.818	0.24526	-175.475
1.7	0.13047	129.243	7.26057	95.548	0.08616	-8.268	0.24807	-178.453
1.75	0.13472	127.648	7.16564	93.586	0.08673	-8.83	0.25113	178.712
1.8	0.13990	126.06	7.06852	91.625	0.08733	-9.205	0.25379	175.901
1.85	0.14563	124.504	6.96617	89.685	0.08792	-9.856	0.25623	173.194
1.9	0.15160	122.941	6.86978	87.806	0.08860	-10.316	0.25716	170.619
1.95	0.15702	121.556	6.77908	85.927	0.08917	-10.882	0.25848	168.384
2	0.16308	120.247	6.68747	84.024	0.08980	-11.465	0.25937	166.234
2.05	0.16757	118.779	6.60108	82.171	0.09037	-12.048	0.26021	164.169
2.1	0.17315	117.547	6.51391	80.255	0.09093	-12.637	0.26130	162.354
2.15	0.17857	116.463	6.42737	78.424	0.09154	-13.316	0.26314	160.699
2.2	0.18449	115.174	6.33611	76.56	0.09210	-13.944	0.26471	159.323
2.25	0.18892	113.697	6.24887	74.732	0.09280	-14.673	0.26627	157.768
2.3	0.19385	112.219	6.16340	72.929	0.09326	-15.366	0.26829	156.541
2.35	0.19754	110.678	6.07930	71.134	0.09383	-16.084	0.27135	155.373

Table 10. Class A Common Emitter S-Parameters at $V_{CC} = 5$ Vdc, $I_{CC} = 70$ mA, $T_C = 25^\circ\text{C}$ (continued)

f GHz	S ₁₁		S ₂₁		S ₁₂		S ₂₂	
	S ₁₁	∠φ	S ₂₁	∠φ	S ₁₂	∠φ	S ₂₂	∠φ
2.4	0.20084	109.125	5.99646	69.327	0.09424	-16.717	0.27492	154.124
2.45	0.20423	107.523	5.91022	67.546	0.09462	-17.459	0.27881	153.075
2.5	0.20717	105.937	5.82783	65.858	0.09514	-18.149	0.28300	151.824
2.55	0.20983	104.482	5.75180	64.078	0.09561	-18.867	0.28750	150.28
2.6	0.21214	102.92	5.67379	62.378	0.09610	-19.566	0.29276	148.947
2.65	0.21446	101.252	5.59418	60.667	0.09647	-20.335	0.29839	147.403
2.7	0.21638	99.767	5.51853	58.949	0.09688	-21.012	0.30389	145.776
2.75	0.21837	98.143	5.44472	57.276	0.09737	-21.79	0.30941	143.933
2.8	0.22001	96.523	5.37675	55.629	0.09779	-22.573	0.31537	142.001
2.85	0.22117	95.017	5.30584	53.932	0.09840	-23.199	0.32118	140.215
2.9	0.22351	93.331	5.24121	52.348	0.09877	-24.027	0.32764	138.273
2.95	0.22552	91.634	5.17536	50.712	0.09912	-24.843	0.33369	136.168
3	0.22752	90.219	5.11494	49.089	0.09981	-25.546	0.34034	134.188
3.05	0.23097	88.535	5.05825	47.462	0.10036	-26.365	0.34528	132.091
3.1	0.23369	87.054	4.99713	45.82	0.10085	-27.171	0.35126	129.624
3.15	0.23656	85.789	4.94222	44.188	0.10141	-27.968	0.35690	127.421
3.2	0.23989	84.265	4.88930	42.551	0.10188	-28.842	0.36188	125.127
3.25	0.24360	82.93	4.83457	40.954	0.10239	-29.629	0.36735	122.986
3.3	0.24688	81.534	4.78423	39.327	0.10292	-30.452	0.37180	120.634
3.35	0.25052	80.161	4.73023	37.654	0.10350	-31.434	0.37649	118.449
3.4	0.25455	78.818	4.68010	36.023	0.10402	-32.349	0.38152	116.317
3.45	0.25901	77.562	4.63102	34.476	0.10446	-33.239	0.38553	114.07
3.5	0.26341	76.264	4.58330	32.823	0.10504	-34.166	0.39006	112.169
3.55	0.26813	74.959	4.53327	31.168	0.10524	-35.066	0.39457	110.035
3.6	0.27237	73.713	4.48601	29.586	0.10576	-36.008	0.39878	107.887

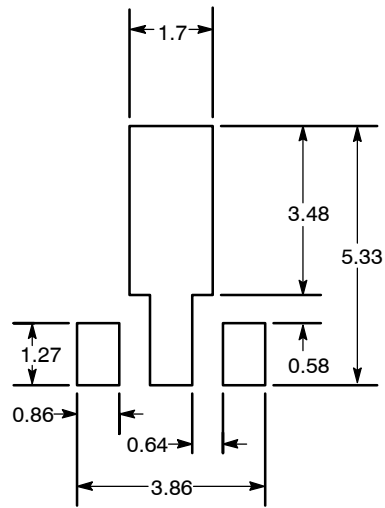

Recommended Solder Stencil

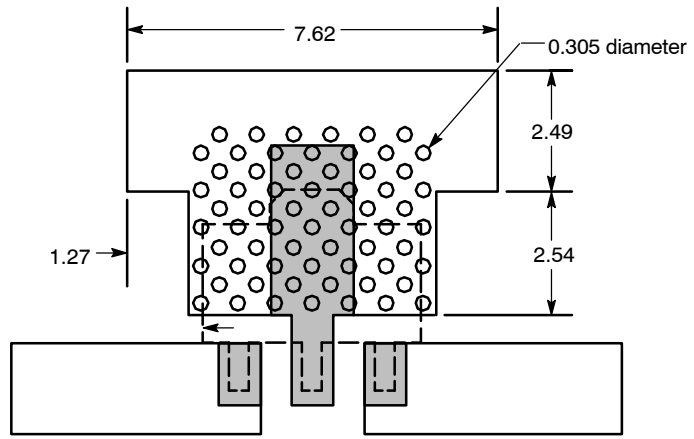

NOTES:

1. THERMAL AND RF GROUNDING CONSIDERATIONS SHOULD BE USED IN PCB LAYOUT DESIGN.
2. DEPENDING ON PCB DESIGN RULES, AS MANY VIAS AS POSSIBLE SHOULD BE PLACED ON THE LANDING PATTERN.
3. IF VIAS CANNOT BE PLACED ON THE LANDING PATTERN, THEN AS MANY VIAS AS POSSIBLE SHOULD BE PLACED AS CLOSE TO THE LANDING PATTERN AS POSSIBLE FOR OPTIMAL THERMAL AND RF PERFORMANCE.
4. RECOMMENDED VIA PATTERN SHOWN HAS 0.381 x 0.762 MM PITCH.

Figure 20. Recommended Mounting Configuration

PACKAGE DIMENSIONS

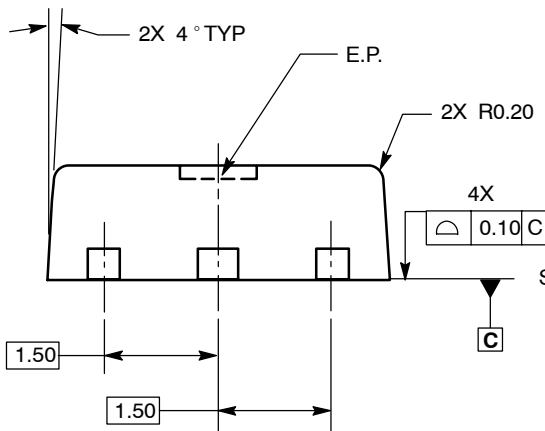
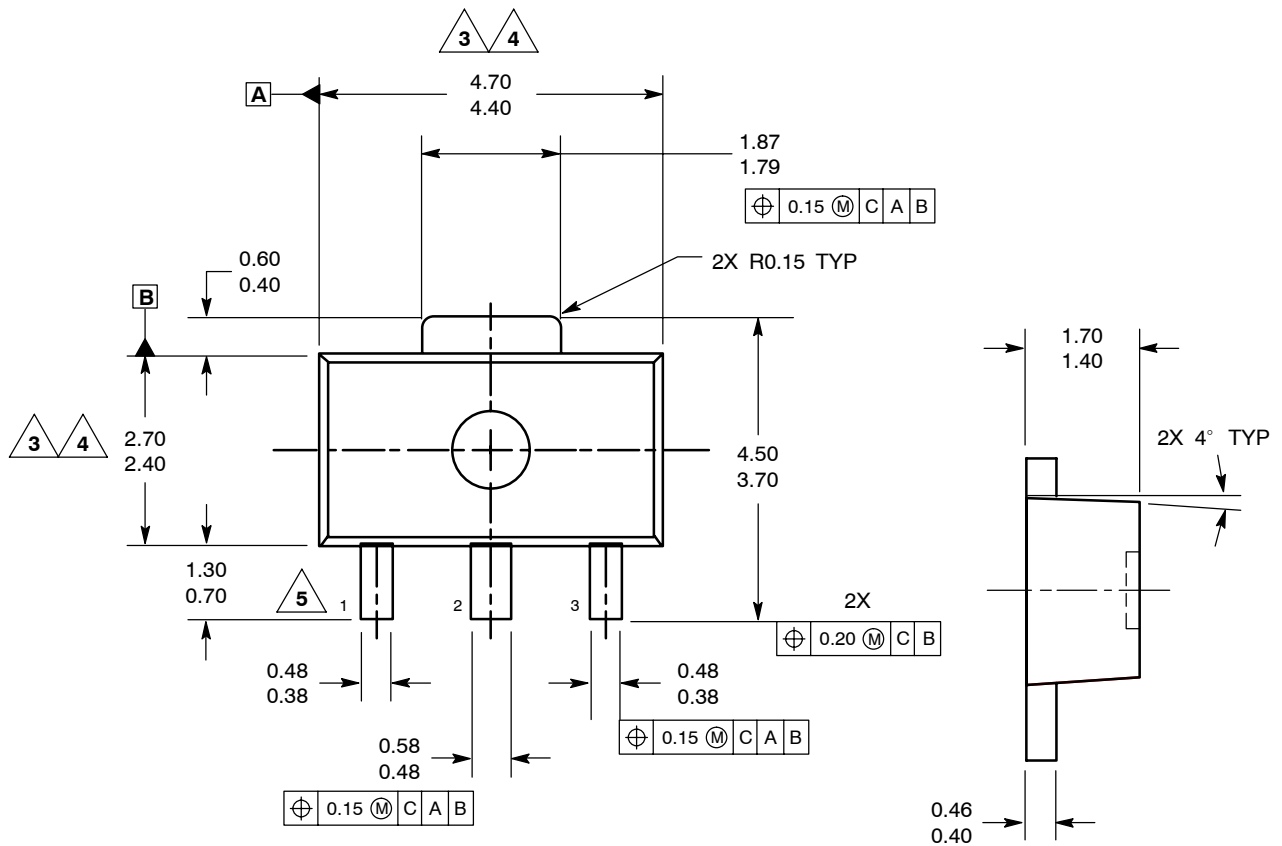

- NOTES:
1. DIMENSIONING AND TOLERANCING PER ASME Y14.5M, 1994.
 2. ALL DIMENSIONS ARE IN MILLIMETERS.
 3. DIMENSION DOES NOT INCLUDE MOLD FLASH, PROTRUSIONS OR GATE BURRS. MOLD FLASH, PROTRUSIONS OR GATE BURRS SHALL NOT EXCEED 0.5MM PER END. DIMENSION DOES NOT INCLUDE INTERLEAD FLASH OR PROTRUSION. INTERLEAD FLASH OR PROTRUSION SHALL NOT EXCEED 0.5MM PER SIDE.
 4. DIMENSIONS ARE DETERMINED AT THE OUTMOST EXTREMES OF THE PLASTIC BODY EXCLUSIVE OF MOLD FLASH, TIE BAR BURRS, GATE BURRS AND INTERLEAD FLASH, BUT INCLUDING ANY MISMATCH BETWEEN THE TOP AND BOTTOM OF THE PLASTIC BODY.
 5. TERMINAL NUMBERS ARE SHOWN FOR REFERENCE ONLY.

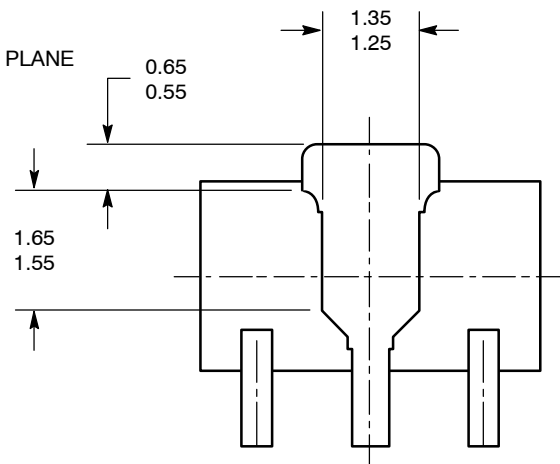

STYLE 1:
 PIN 1. RF INPUT
 2. GROUND
 3. RF OUTPUT

**CASE 1514-01
 ISSUE C
 SOT-89
 PLASTIC**

BOTTOM VIEW

MMG3012NT1

How to Reach Us:

Home Page:
www.freescale.com

E-mail:
support@freescale.com

USA/Europe or Locations Not Listed:
Freescale Semiconductor
Technical Information Center, CH370
1300 N. Alma School Road
Chandler, Arizona 85224
+1-800-521-6274 or +1-480-768-2130
support@freescale.com

Europe, Middle East, and Africa:
Freescale Halbleiter Deutschland GmbH
Technical Information Center
Schatzbogen 7
81829 Muenchen, Germany
+44 1296 380 456 (English)
+46 8 52200080 (English)
+49 89 92103 559 (German)
+33 1 69 35 48 48 (French)
support@freescale.com

Japan:
Freescale Semiconductor Japan Ltd.
Headquarters
ARCO Tower 15F
1-8-1, Shimo-Meguro, Meguro-ku,
Tokyo 153-0064
Japan
0120 191014 or +81 3 5437 9125
support.japan@freescale.com

Asia/Pacific:
Freescale Semiconductor Hong Kong Ltd.
Technical Information Center
2 Dai King Street
Tai Po Industrial Estate
Tai Po, N.T., Hong Kong
+800 2666 8080
support.asia@freescale.com

For Literature Requests Only:
Freescale Semiconductor Literature Distribution Center
P.O. Box 5405
Denver, Colorado 80217
1-800-441-2447 or 303-675-2140
Fax: 303-675-2150
LDCForFreescaleSemiconductor@hibbertgroup.com

RoHS-compliant and/or Pb-free versions of Freescale products have the functionality and electrical characteristics of their non-RoHS-compliant and/or non-Pb-free counterparts. For further information, see <http://www.freescale.com> or contact your Freescale sales representative.

For information on Freescale's Environmental Products program, go to <http://www.freescale.com/epp>.

Information in this document is provided solely to enable system and software implementers to use Freescale Semiconductor products. There are no express or implied copyright licenses granted hereunder to design or fabricate any integrated circuits or integrated circuits based on the information in this document.

Freescale Semiconductor reserves the right to make changes without further notice to any products herein. Freescale Semiconductor makes no warranty, representation or guarantee regarding the suitability of its products for any particular purpose, nor does Freescale Semiconductor assume any liability arising out of the application or use of any product or circuit, and specifically disclaims any and all liability, including without limitation consequential or incidental damages. "Typical" parameters that may be provided in Freescale Semiconductor data sheets and/or specifications can and do vary in different applications and actual performance may vary over time. All operating parameters, including "Typicals", must be validated for each customer application by customer's technical experts. Freescale Semiconductor does not convey any license under its patent rights nor the rights of others. Freescale Semiconductor products are not designed, intended, or authorized for use as components in systems intended for surgical implant into the body, or other applications intended to support or sustain life, or for any other application in which the failure of the Freescale Semiconductor product could create a situation where personal injury or death may occur. Should Buyer purchase or use Freescale Semiconductor products for any such unintended or unauthorized application, Buyer shall indemnify and hold Freescale Semiconductor and its officers, employees, subsidiaries, affiliates, and distributors harmless against all claims, costs, damages, and expenses, and reasonable attorney fees arising out of, directly or indirectly, any claim of personal injury or death associated with such unintended or unauthorized use, even if such claim alleges that Freescale Semiconductor was negligent regarding the design or manufacture of the part.

Freescale™ and the Freescale logo are trademarks of Freescale Semiconductor, Inc. All other product or service names are the property of their respective owners.
© Freescale Semiconductor, Inc. 2005. All rights reserved.

