

Integrated Silicon Pressure Sensor for Manifold Absolute Pressure Applications On-Chip Signal Conditioned, Temperature Compensated and Calibrated

The Freescale MPX4200A series Manifold Absolute Pressure (MAP) sensor for turbo boost engine control is designed to sense absolute air pressure within the intake manifold. This measurement can be used to compute the amount of fuel required for each cylinder.

The MPX4200A series sensor integrates on-chip, bipolar op amp circuitry and thin film resistor networks to provide a high level analog output signal and temperature compensation. The small form factor and reliability of on-chip integration make the Freescale MAP sensor a logical and economical choice for automotive system designers.

Features

- Specifically Designed for Intake Manifold Absolute Pressure Sensing in Engine Control Systems
- Patented Silicon Shear Stress Strain Gauge
- Temperature Compensated Over -40° to $+125^{\circ}\text{C}$
- Offers Reduction in Weight and Volume Compared to Existing Hybrid Modules
- Durable Epoxy Unibody Element

Typical Applications

- Manifold Sensing for Automotive Systems
- Ideally suited for Microprocessor or Microcontroller-Based Systems
- Also ideal for Non-Automotive Applications

| ORDERING INFORMATION | | | | |
|-----------------------------------|-------------------|----------|----------------------|----------------|
| Device Type | Options | Case No. | MPX Series Order No. | Device Marking |
| UNIBODY PACKAGE (MPX4200A SERIES) | | | | |
| Basic Element | Absolute, Element | 867 | MPX4200A | MPX4200A |

MPX4200A SERIES

INTEGRATED
 PRESSURE SENSOR
 20 to 200 kPa (2.9 to 29 psi)
 0.3 to 4.9 V OUTPUT

UNIBODY PACKAGE

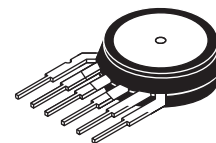

MPX4200A
 CASE 867-08

PIN NUMBERS⁽¹⁾

| | | | |
|---|-----------|---|-----|
| 1 | V_{out} | 4 | N/C |
| 2 | GND | 5 | N/C |
| 3 | V_S | 6 | N/C |

1. Pins 4, 5, and 6 are internal device connections. Do not connect to external circuitry or ground. Pin 1 is noted by the notch in the lead.

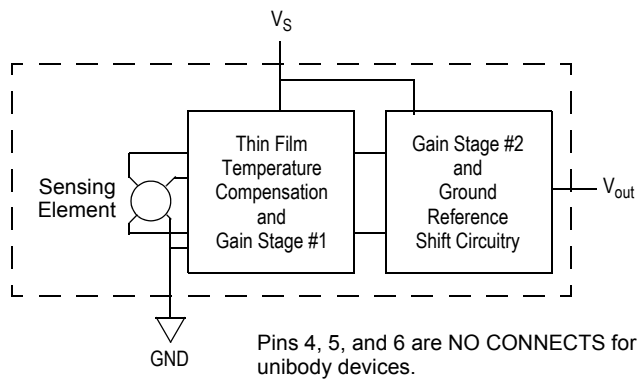

Figure 1. Fully Integrated Pressure Sensor Schematic

Table 1. Maximum Ratings⁽¹⁾

| Rating | Symbol | Value | Unit |
|----------------------------|-----------|-------------|------|
| Maximum Pressure (P1 > P2) | P_{MAX} | 800 | kPa |
| Storage Temperature | T_{STG} | -40 to +125 | °C |
| Operating Temperature | T_A | -40 to +125 | °C |

1. Exposure beyond the specified limits may cause permanent damage or degradation to the device.

Table 2. Operating Characteristics ($V_S = 5.1$ Vdc, $T_A = 25^\circ\text{C}$ unless otherwise noted, $P_1 > P_2$.
Decoupling circuit shown in [Figure 3](#) required to meet electrical specifications.)

| Characteristic | Symbol | Min | Typ | Max | Unit |
|--|-----------|-------|-------|-------|-------------|
| Pressure Range ⁽¹⁾ | P_{OP} | 20 | — | 200 | kPa |
| Supply Voltage ⁽²⁾ | V_S | 4.85 | 5.1 | 5.35 | Vdc |
| Supply Current | I_o | — | 7.0 | 10 | mAdc |
| Minimum Pressure Offset @ $V_S = 5.1$ Volts ⁽³⁾ (0 to 85°C) | V_{off} | 0.199 | 0.306 | 0.413 | Vdc |
| Full Scale Output @ $V_S = 5.1$ Volts ⁽⁴⁾ (0 to 85°C) | V_{FSO} | 4.725 | 4.896 | 4.978 | Vdc |
| Full Scale Span @ $V_S = 5.1$ Volts ⁽⁵⁾ (0 to 85°C) | V_{FSS} | — | 4.590 | — | Vdc |
| Accuracy ⁽⁶⁾ (0 to 85°C) | — | — | — | ±1.5 | % V_{FSS} |
| Sensitivity | V/P | — | 25.5 | — | mV/kPa |
| Response Time ⁽⁷⁾ | t_R | — | 1.0 | — | ms |
| Output Source Current at Full Scale Output | I_{o+} | — | 0.1 | — | mAdc |
| Warm-Up Time ⁽⁸⁾ | — | — | 20 | — | ms |
| Offset Stability ⁽⁹⁾ | — | — | ±0.5 | — | % V_{FSS} |

- 1.0 kPa (kiloPascal) equals 0.145 psi.
- Device is ratiometric within this specified excitation range.
- Offset (V_{off}) is defined as the output voltage at the minimum rated pressure.
- Full Scale Output (V_{FSO}) is defined as the output voltage at the maximum or full rated pressure.
- Full Scale Span (V_{FSS}) is defined as the algebraic difference between the output voltage at full rated pressure and the output voltage at the minimum rated pressure.
- Accuracy (error budget) consists of the following:
 - Linearity: Output deviation from a straight line relationship with pressure over the specified pressure range.
 - Temperature Hysteresis: Output deviation at any temperature within the operating temperature range, after the temperature is cycled to and from the minimum or maximum operating temperature points, with zero differential pressure applied.
 - Pressure Hysteresis: Output deviation at any pressure within the specified range, when this pressure is cycled to and from the minimum or maximum rated pressure, at 25°C.
 - TcSpan: Output deviation over the temperature range of 0 to 85°C, relative to 25°C.
 - TcOffset: Output deviation with minimum rated pressure applied, over the temperature range of 0 to 85°C, relative to 25°C.
 - Variation from Nominal: The variation from nominal values, for Offset or Full Scale Span, as a percent of V_{FSS} , at 25°C.
- Response Time is defined as the time for the incremental change in the output to go from 10% to 90% of its final value when subjected to a specified step change in pressure.
- Warm-up Time is defined as the time required for the product to meet the specified output voltage after the Pressure has been stabilized.
- Offset Stability is the product's output deviation when subjected to 1000 hours of Pulsed Pressure, Temperature Cycling with Bias Test.

Table 3. Mechanical Characteristics

| Characteristics | Typ | Unit |
|----------------------------------|-----|-------|
| Weight, Basic Element (Case 867) | 4.0 | grams |

ON-CHIP TEMPERATURE COMPENSATION AND CALIBRATION

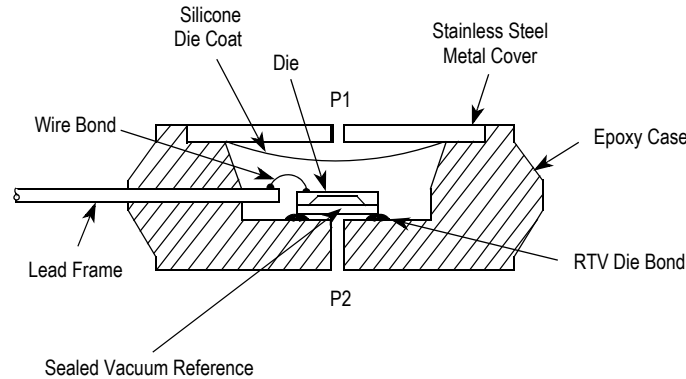

Figure 2. Cross Sectional Diagram (not to scale)

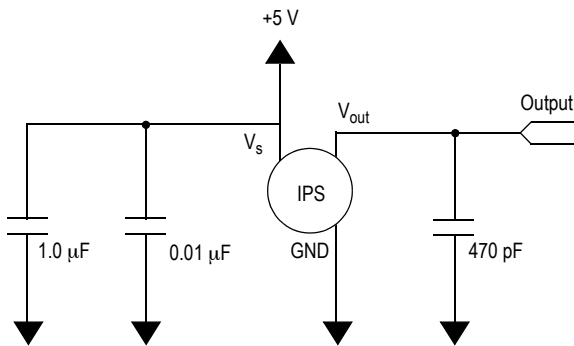

Figure 3. Recommended Power Supply Decoupling and Output Filtering

(For additional output filtering, please refer to Application Note AN1646)

Figure 2 illustrates the absolute sensing chip in the basic chip carrier (Case 867). A fluorosilicone gel isolates the die surface and wire bonds from the environment, while allowing the pressure signal to be transmitted to the sensor diaphragm. The MPX4200A series pressure sensor operating characteristics, and internal reliability and qualification tests are based on use of dry air as the pressure media. Media, other than dry air, may have adverse effects on sensor performance and long-term reliability. Contact the factory for information regarding media compatibility in your application.

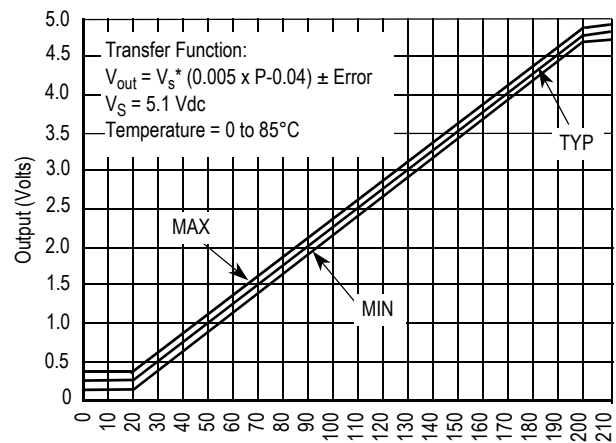
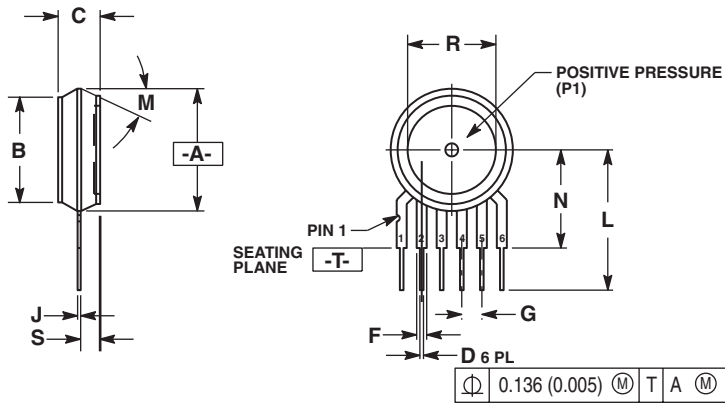

Figure 4. Output versus Absolute Pressure

Figure 3 shows the recommended decoupling circuit for interfacing the output of the integrated sensor to the A/D input of a microprocessor or microcontroller. Proper decoupling of the power supply is recommended.

Figure 4 shows the sensor output signal relative to pressure input. Typical minimum and maximum output curves are shown for operation over temperature range of 0° to 85°C. The output will saturate outside of the specified pressure range.

PACKAGE DIMENSIONS



- NOTES:
1. DIMENSIONING AND TOLERANCING PER ANSI Y14.5M, 1982.
 2. CONTROLLING DIMENSION: INCH.
 3. DIMENSION -A- IS INCLUSIVE OF THE MOLD STOP RING. MOLD STOP RING NOT TO EXCEED 16.00 (0.630).

| DIM | INCHES | | MILLIMETERS | |
|-----|-----------|-------|-------------|-------|
| | MIN | MAX | MIN | MAX |
| A | 0.595 | 0.630 | 15.11 | 16.00 |
| B | 0.514 | 0.534 | 13.06 | 13.56 |
| C | 0.200 | 0.220 | 5.08 | 5.59 |
| D | 0.027 | 0.033 | 0.68 | 0.84 |
| F | 0.048 | 0.064 | 1.22 | 1.63 |
| G | 0.100 BSC | | 2.54 BSC | |
| J | 0.014 | 0.016 | 0.36 | 0.40 |
| L | 0.695 | 0.725 | 17.65 | 18.42 |
| M | 30° NOM | | 30° NOM | |
| N | 0.475 | 0.495 | 12.07 | 12.57 |
| R | 0.430 | 0.450 | 10.92 | 11.43 |
| S | 0.090 | 0.105 | 2.29 | 2.66 |

- STYLE 1:
 PIN 1. VOUT
 2. GROUND
 3. VCC
 4. V1
 5. V2
 6. VEX

- STYLE 2:
 PIN 1. OPEN
 2. GROUND
 3. -VOUT
 4. VSUPPLY
 5. +VOUT
 6. OPEN

- STYLE 3:
 PIN 1. OPEN
 2. GROUND
 3. +VOUT
 4. +VSUPPLY
 5. -VOUT
 6. OPEN

CASE 867-08 ISSUE N UNIBODY PACKAGE

How to Reach Us:

Home Page:

www.freescale.com

Web Support:

<http://www.freescale.com/support>

USA/Europe or Locations Not Listed:

Freescale Semiconductor, Inc.
Technical Information Center, EL516
2100 East Elliot Road
Tempe, Arizona 85284
+1-800-521-6274 or +1-480-768-2130
www.freescale.com/support

Europe, Middle East, and Africa:

Freescale Halbleiter Deutschland GmbH
Technical Information Center
Schatzbogen 7
81829 Muenchen, Germany
+44 1296 380 456 (English)
+46 8 52200080 (English)
+49 89 92103 559 (German)
+33 1 69 35 48 48 (French)
www.freescale.com/support

Japan:

Freescale Semiconductor Japan Ltd.
Headquarters
ARCO Tower 15F
1-8-1, Shimo-Meguro, Meguro-ku,
Tokyo 153-0064
Japan
0120 191014 or +81 3 5437 9125
support.japan@freescale.com

Asia/Pacific:

Freescale Semiconductor Hong Kong Ltd.
Technical Information Center
2 Dai King Street
Tai Po Industrial Estate
Tai Po, N.T., Hong Kong
+800 2666 8080
support.asia@freescale.com

For Literature Requests Only:

Freescale Semiconductor Literature Distribution Center
P.O. Box 5405
Denver, Colorado 80217
1-800-441-2447 or 303-675-2140
Fax: 303-675-2150
LDCForFreescaleSemiconductor@hibbertgroup.com

Information in this document is provided solely to enable system and software implementers to use Freescale Semiconductor products. There are no express or implied copyright licenses granted hereunder to design or fabricate any integrated circuits or integrated circuits based on the information in this document.

Freescale Semiconductor reserves the right to make changes without further notice to any products herein. Freescale Semiconductor makes no warranty, representation or guarantee regarding the suitability of its products for any particular purpose, nor does Freescale Semiconductor assume any liability arising out of the application or use of any product or circuit, and specifically disclaims any and all liability, including without limitation consequential or incidental damages. "Typical" parameters that may be provided in Freescale Semiconductor data sheets and/or specifications can and do vary in different applications and actual performance may vary over time. All operating parameters, including "Typicals", must be validated for each customer application by customer's technical experts. Freescale Semiconductor does not convey any license under its patent rights nor the rights of others. Freescale Semiconductor products are not designed, intended, or authorized for use as components in systems intended for surgical implant into the body, or other applications intended to support or sustain life, or for any other application in which the failure of the Freescale Semiconductor product could create a situation where personal injury or death may occur. Should Buyer purchase or use Freescale Semiconductor products for any such unintended or unauthorized application, Buyer shall indemnify and hold Freescale Semiconductor and its officers, employees, subsidiaries, affiliates, and distributors harmless against all claims, costs, damages, and expenses, and reasonable attorney fees arising out of, directly or indirectly, any claim of personal injury or death associated with such unintended or unauthorized use, even if such claim alleges that Freescale Semiconductor was negligent regarding the design or manufacture of the part.

Freescale™ and the Freescale logo are trademarks of Freescale Semiconductor, Inc. All other product or service names are the property of their respective owners.

© Freescale Semiconductor, Inc. 2006. All rights reserved.

