

Fiber Optic GaAlAs High Speed LED

Types OPF395A, OPF395B, OPF395C, OPF395D

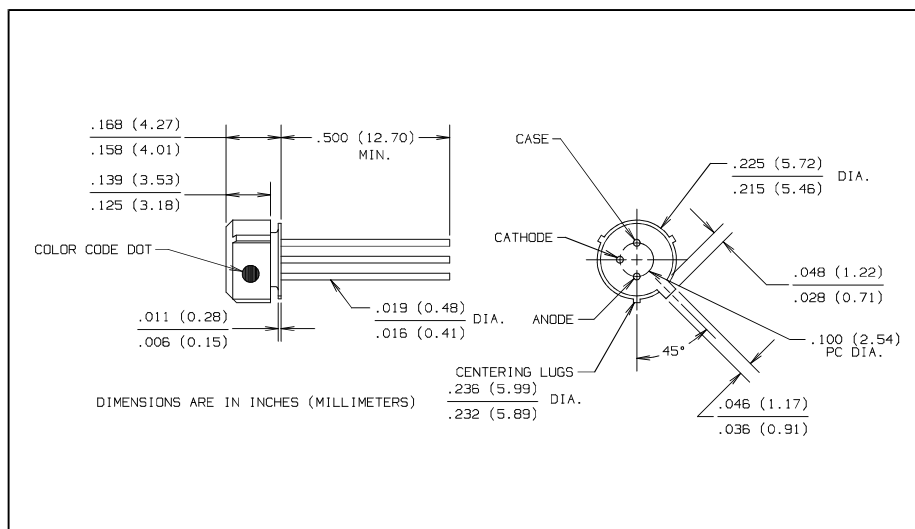
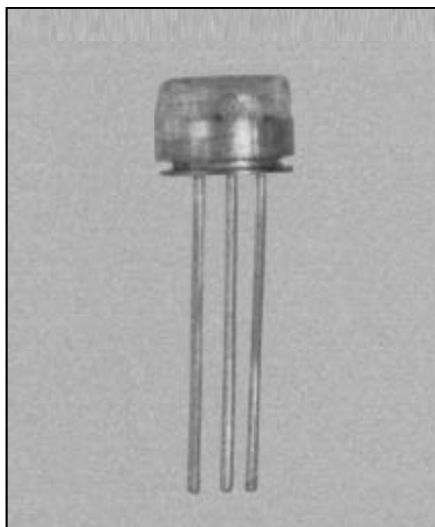

Features

- Electrically isolated plastic cap package
- High radiant output for fiber optic applications
- High speed
- Designed to self align in the 0.228 inch diameter bore of standard fiber optic receptacles. Press fit simplifies component installation.

Description

The OPF395 series LED provides fiber optic users with high coupled power and wide bandwidth in a low cost package.

The LED's are designed to interface with multimode optical fibers from 50/125 to 200/300 microns.

Absolute Maximum Ratings ($T_A = 25^\circ\text{C}$ unless otherwise noted)

Reverse Voltage	1.0 V
Continuous Forward Current	100 mA ⁽⁴⁾
Storage Temperature Range	-55° C to +115° C
Operating Temperature Range	-40° C to +100° C
Lead Soldering Temperature [1/16 inch (1.6 mm) from case for 5 sec. with soldering iron]	240° C ⁽¹⁾

Notes:

- (1) RMA flux is recommended. Duration can be extended to 10 sec. max when flow soldering.
- (2) Graded index fiber, 50 μm core, N.A. = 0.20.
- (3) To convert radiant power output to dBm, use the following expression: $\text{dBm} = 10 \log (\mu\text{W}/1000)$.
- (4) Derate linearly @ 1.0 mA/° C above 25° C.
- (5) Prebias @ 5 mA current.

LED Burn-in

All LED's are subject to 100% burn-in testing. Test conditions are 96 hours at 100 mA continuous current in 25° C ambient.

TYPICAL COUPLED POWER into OPTICAL FIBER

Typical Coupled Power $I_F = 100 \text{ mA} @ 25^\circ\text{C}$						
Fiber	Refractive Index	N.A.	OPF395D	OPF395C	OPF395B	OPF395A
50/125 μm	Graded	0.20	7.5 μW	12.5 μW	18 μW	25 μW
62.5/125 μm	Graded	0.28	27 μW	35 μW	45 μW	75 μW
100/140 μm	Graded	0.29	58 μW	85 μW	115 μW	170 μW
200/300 μm^*	Step	0.41	290 μW	450 μW	545 μW	650 μW

*PCS - Plastic Clad Silica

Types OPF395A, OPF395B, OPF395C, OPF395D

Electrical Characteristics ($T_A = 25^\circ\text{C}$ unless otherwise noted)

SYMBOL	PARAMETER	DOT	MIN	TYP	MAX	UNITS	TEST CONDITIONS
P_O	Radiant Power Output	OPF395D (Silver)	5.0	7.5		μW	$I_F = 100\text{ mA}^{(2)}$
		OPF395C (Black)	10.0	12.5			
		OPF395B (Green)	15.0	18.0			
		OPF395A (Orange)	20.0	25.0			
V_F	Forward Voltage			1.8	2.0	V	$I_F = 100\text{ mA}$
λ_p	Peak Output Wavelength		830	850	870	nm	$I_F = 50\text{ mA}$
B	Spectral Bandwidth Between Half Power Points			35		nm	$I_F = 50\text{ mA}$
t_r	Output Rise Time			3.5	4.5	ns	$I_F = 100\text{ mA}, 10\%-90\%^{(5)}$
t_f	Output Fall Time			3.5	4.5	ns	$I_F = 100\text{ mA}, 90\%-10\%^{(5)}$

Typical Performance Curves

Relative Coupled Power vs. Forward Current

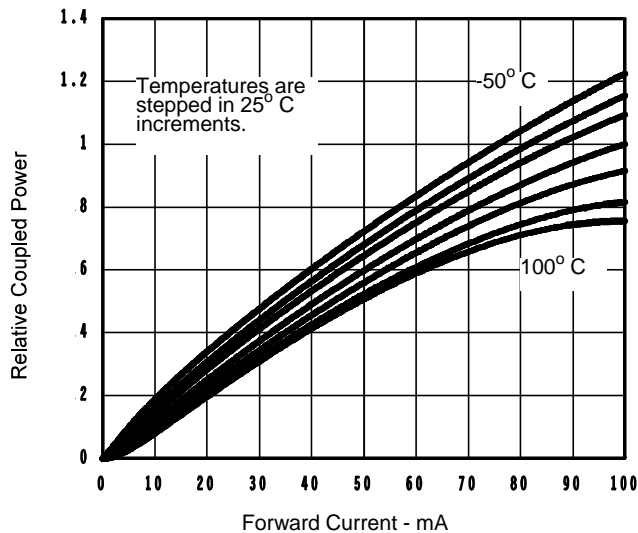

Forward Voltage vs. Forward Current

