



DATA SHEET

SD320T~SD3100T

SURFACE MOUNT SCHOTTKY BARRIER RECTIFIERS

VOLTAGE 20 to 100 Volts CURRENT - 3 Ampere

TO-251AB

Unit: inch (mm)

FEATURES

- Plastic package has Underwriters Laboratory Flammability Classification 94V-O
- For surface mounted applications
- Low profile package
- Built-in strain relief
- Low power loss, High efficiency
- High surge capacity
- For use in low voltage high frequency inverters, free wheeling, and polarity protection applications
- High temperature soldering guaranteed: 260°C/10 seconds at terminals

MECHANICAL DATA

Case: O-251AB molded plastic

Terminals: Solder plated, solderable per MIL-STD-750, Method 2026

Polarity: As marking

Weight: 0.015 ounces, 0.4grams.

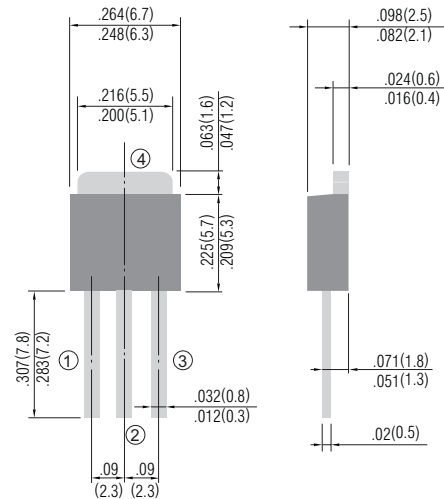

MAXIMUM RATINGS AND ELECTRICAL CHARACTERISTICS

Ratings at 25°C ambient temperature unless otherwise specified.

Single phase, half wave, 60 Hz, resistive or inductive load.

For capacitive load, derate current by 20%

	SD320T	SD330T	SD340T	SD350T	SD360T	SD380T	SD3100T	UNITS
Maximum Recurrent Peak Reverse Voltage	20	30	40	50	60	80	100	V
Maximum RMS Voltage	14	21	28	35	42	56	70	V
Maximum DC Blocking Voltage	20	30	40	50	60	80	100	V
Maximum Average Forward Rectified Current at Tc=75°C	3							A
Peak Forward Surge Current, 8.3 ms single half sine-wave superimposed on rated load (JEDEC method)	75							A
Maximum Instantaneous Forward Voltage at 3.0A (Note 1)	0.50		0.64			0.85		V
Maximum DC Reverse Current at Tc=25°C	0.2							mA
DC Blocking Voltage per element Tc=100°C	20							
Maximum Thermal Resistance (Note 2)	80							°C/W
Operating and Storage Temperature Range	-55 to +125							°C
Storage Temperature Range	-65 to +150							°C

NOTES:

1. Thermal Resistance Junction to Ambient .



RATING AND CHARACTERISTIC CURVES

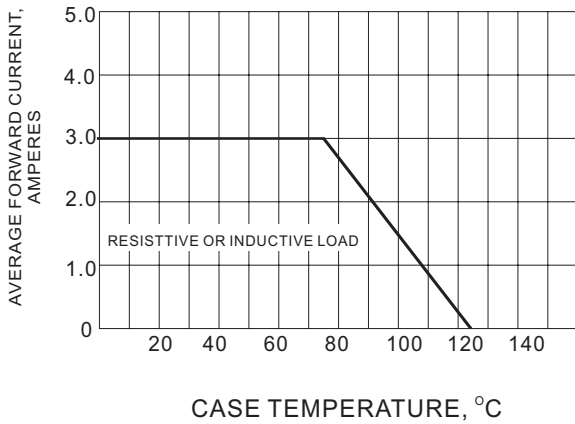

Fig.1- FORWARD CURRENT DERATING CURVE

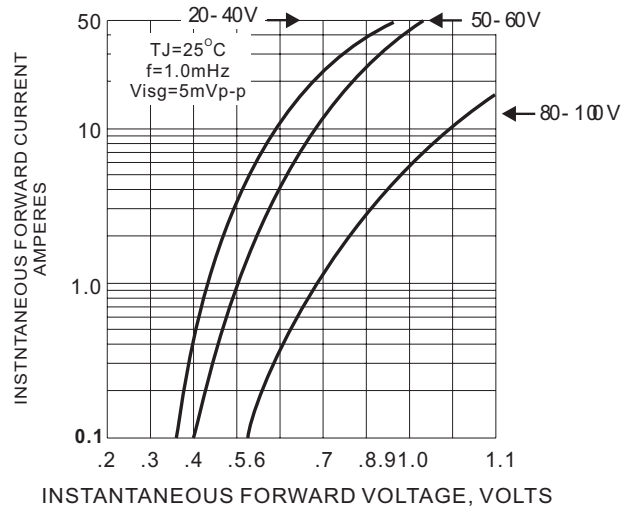

Fig.2- TYPICAL INSTANTANEOUS FORWARD CHARACTERISTIC

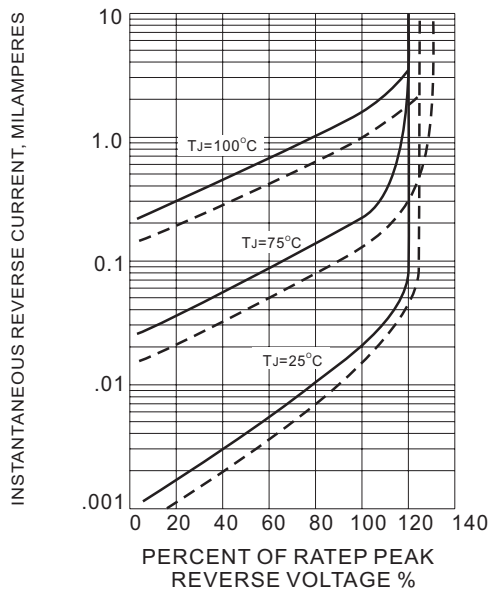

Fig.3- TYPICAL REVERSE CHARACTERISTICS

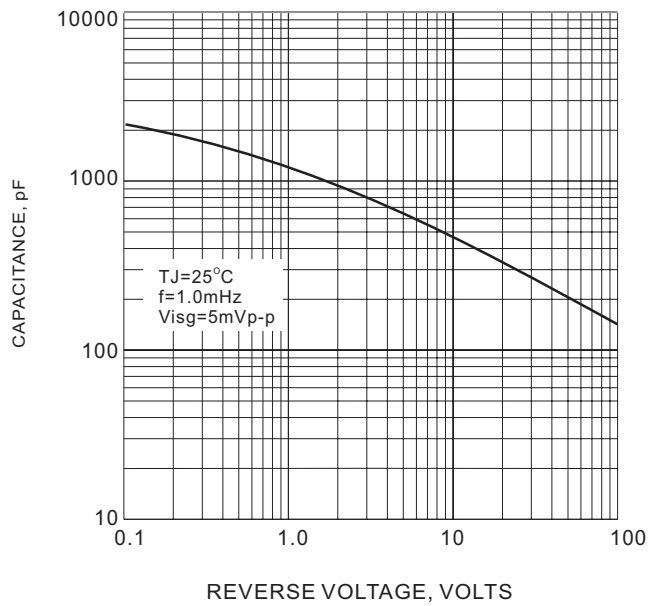

Fig.4- TYPICAL JUNCTION CAPACITANCE

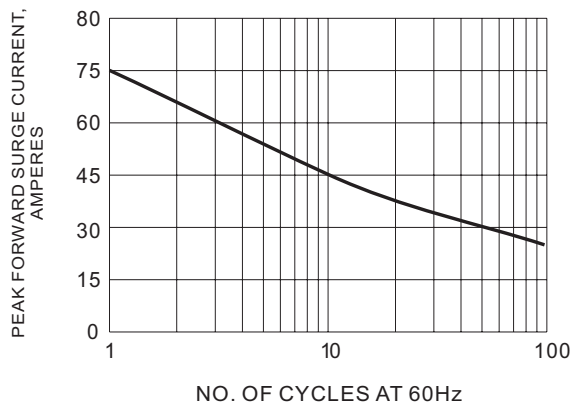

Fig.5- MAXIMUM NON-REPETITIVE SURGE CURRENT