

TECHNICAL DATA
 DATA SHEET 548, REV. -

Three-Phase MOSFET/IGBT Bridge Driver

Absolute Maximum Ratings

Absolute Maximum Rating indicate sustained limits beyond which damage to the device may occur. All voltage parameters are absolute voltages referenced to COM. The thermal resistance is specified under board mounted and still air conditions.

PARAMETER	SYMBOL	MIN	TYP	MAX	UNIT
High Side Floating Supply Voltage	$V_{B1,2,3}$	-0.3	-	325	V
High Side Floating Supply Voltage	$V_{S1,2,3}$	$V_{B1,2,3} - 25$	-	$V_{B1,2,3} + 0.3$	V
Supply Voltage	V_{CC}	-0.3	-	25	V
Logic Ground	V_{SS}	- 0.3	-	$V_{CC} + 0.3$	V
Logic Input Voltage (\overline{HIN} , \overline{LIN} , ITRIP $\overline{FLT-CLR}$, SD)	V_{IN}	$V_{SS} - 0.3$	-	$V_{CC} + 0.3$	V
Op-Amp Input Voltage	V_{IN-Amp}	$V_{SS} - 0.3$	-	$V_{CC} + 0.3$	V
FAULT Output Voltage	V_{FLT}	$V_{SS} - 0.3$	-	$V_{CC} + 0.3$	V
Thermal Resistance	R_{thJA}		-	80	$^{\circ}C/W$
Junction Temperature	T_j	-55	-	150	$^{\circ}C$
Lead Soldering Temperature, 10 sec	T_L	-	-	250	$^{\circ}C$

Recommended Operating Conditions

PARAMETER	SYMBOL	MIN	TYP	MAX	UNIT
High Side Floating Supply Voltage	$V_{B1,2,3}$	$V_{S1,2,3} + 10$	-	$V_{S1,2,3} + 20$	V
High Side Floating Supply Voltage	$V_{S1,2,3}$	-5	-	300	V
Supply Voltage	V_{CC}	10	-	20	V
Logic Ground	V_{SS}	- 5	-	5	V
Logic Input Voltage (\overline{HIN} , \overline{LIN} , ITRIP $\overline{FLT-CLR}$, SD)	V_{IN}	V_{SS}	-	$V_{SS} + 5$	V
Op-Amp Input Voltage	V_{IN-Amp}	V_{SS}	-	$V_{SS} + 5$	V
FAULT Output Voltage	V_{FLT}	V_{SS}	-	V_{CC}	V

Dynamic Characteristics $V_{CC}=V_{BS1,2,3} = 15V, V_{S1,2,3} = V_{SS}, C_L = 1 \text{ nF}$

PARAMETER	TEST CONDITIONS	SYMBOL	MIN	TYP	MAX	UNIT
Turn-On Propagation Delay	$V_{IN} = 0 \text{ \& 5V}$ $V_{S1,2,3} = 0 \text{ to } 300V$	t_{on}	-	700	-	nsec
Turn-Off Propagation Delay		t_{off}	-	700	-	nsec
Turn-On Rise Time		t_r	-	75	-	nsec
Turn-Off Fall Time		t_f	-	35	-	nsec
SD to Output Shutdown Propagation Delay	$V_{IN}, V_{ITRIP} = 0V,$ $V_{SD} = 0 \text{ \& } 5V$	t_{sd}	-	700	-	nsec
ITRIP to Output Shutdown Propagation Delay	$V_{IN} = 0V,$ $V_{ITRIP} = 0 \text{ \& } 5V$	t_{itrip}	-	700	-	nsec
ITRIP Blanking Time	$V_{ITRIP} = 1V$	t_{bl}	-	400	-	nsec
ITRIP to FAULT Shutdown Propagation Delay	$V_{IN} = 0V,$ $V_{ITRIP} = 0 \text{ \& } 5V$	t_{flt}	-	500	-	nsec
Input Filter Time (\overline{HIN} , \overline{LIN} , & SD)	$V_{IN} = 0 \text{ \& } 5V$	t_{fil}		310		nsec
Deadtime, LS Turn-Off to HS Turn-on & HS Turn-Off to LS Turn-On	$V_{IN} = 0 \text{ \& } 5V$	DT	-	200	-	nsec

Static Characteristics $V_{CC}=V_{BS1,2,3} = 15V, V_{S1,2,3} = V_{SS}$

PARAMETER	TEST CONDITIONS	SYMBOL	MIN	TYP	MAX	UNIT
Logic "0" Input Voltage (Output = LO)		V_{IH}	2.2	-	-	V
Logic "1" Input Voltage (Output = HI)		V_{IL}	-	-	0.8	V
Logic "0" Fault Clear Input Voltage		$V_{FCLR,IH}$	2.2	-	-	V
Logic "1" Fault Clear Input Voltage		$V_{FCLR,IL}$	-	-	0.8	V
SD Input Positive Going Threshold		$V_{SD,TH+}$	-	1.8	-	V
SD Input Negative Going Threshold		$V_{SD,TH-}$	-	1.5	-	V
ITRIP Input Positive Going Threshold		$V_{IT,TH+}$	-	0.485	-	V
ITRIP Input Negative Going Threshold		$V_{IT,TH-}$	-	0.400	-	V
Quiescent V_{CC} Supply Current	$V_{IN} = 0V, \text{ or } 5V$	I_{QCC}	-	4	-	mA
Supply Under Voltage Positive Going Threshold		V_{CCIU+} V_{BSIU+}	-	10.4	-	V
Supply Under Voltage Negative Going Threshold		V_{CCIU-} V_{BSIU-}	-	9.4	-	V
Output High Short Circuit Pulsed Current	$V_{OUT} = 0V,$ $V_{IN} = 0V,$ $t_p < 10\mu\text{sec}$	I_{O+}	200	250	-	mA
Output Low Short Circuit Pulsed Current	$V_{OUT} = 0V,$ $V_{IN} = 0V,$ $t_p < 10\mu\text{sec}$	I_{O-}	420	500	-	mA

Schematic Diagram

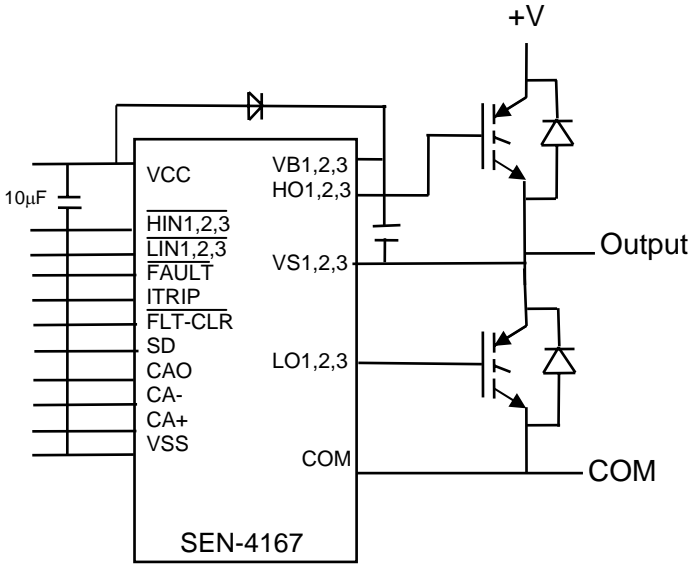

Package Layout:

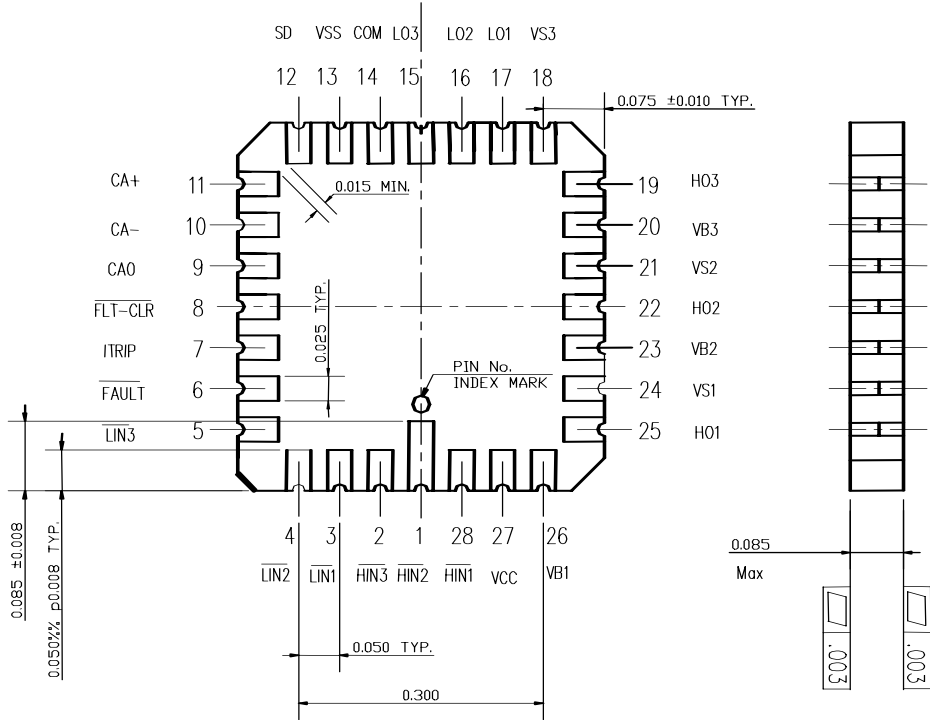

TECHNICAL DATA

DISCLAIMER:

1- The information given herein, including the specifications and dimensions, is subject to change without prior notice to improve product characteristics. Before ordering, purchasers are advised to contact the Sensitron Semiconductor sales department for the latest version of the datasheet(s).

2- In cases where extremely high reliability is required (such as use in nuclear power control, aerospace and aviation, traffic equipment, medical equipment, and safety equipment), safety should be ensured by using semiconductor devices that feature assured safety or by means of users' fail-safe precautions or other arrangement.

3- In no event shall Sensitron Semiconductor be liable for any damages that may result from an accident or any other cause during operation of the user's units according to the datasheet(s). Sensitron Semiconductor assumes no responsibility for any intellectual property claims or any other problems that may result from applications of information, products or circuits described in the datasheets.

4- In no event shall Sensitron Semiconductor be liable for any failure in a semiconductor device or any secondary damage resulting from use at a value exceeding the absolute maximum rating.

5- No license is granted by the datasheet(s) under any patents or other rights of any third party or Sensitron Semiconductor.

6- The datasheet(s) may not be reproduced or duplicated, in any form, in whole or part, without the expressed written permission of Sensitron Semiconductor.

7- The products (technologies) described in the datasheet(s) are not to be provided to any party whose purpose in their application will hinder maintenance of international peace and safety nor are they to be applied to that purpose by their direct purchasers or any third party. When exporting these products (technologies), the necessary procedures are to be taken in accordance with related laws and regulations.