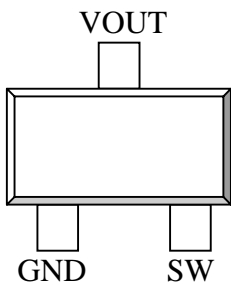
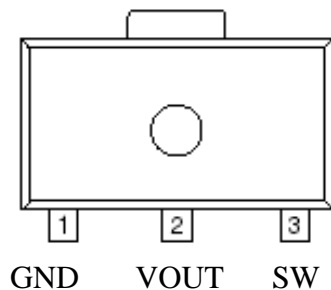

High Efficiency PFM**DESCRIPTION**

The ST1638 is a high efficiency PFM step-up DC/DC converter for application using battery powered devices. Only three external components are required to construct a low ripple, high efficiency converter. ST1638 can start up from 0.9V input voltage with 1mA load.

The space saving SOT-89 and SOT-23 packages make ST1638 an ideal choice for space conscious applications.

PIN CONFIGURATION**SOT-23-3L****SOT-89****APPLICATIONS**

- Battery Powered Devices
- Camera
- PDA
- Hand Held Communication Equipment
- Camcorder
- Power Source for Applications which Require Higher Voltage than Batteries can Provide

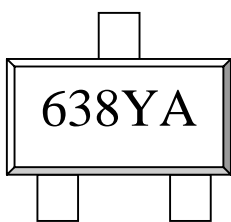
PART MARKING**SOT-23-3L**

Y : Year
A : Day Code

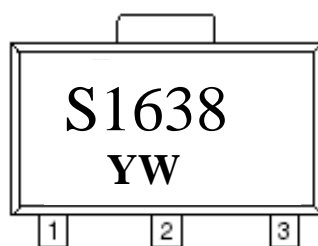
SOP-89

Y : Year
A : Day Code

FEATURES

- Larger than 85% Efficiency
- Low Startup Voltage, 0.9V at 1mA
- Low Ripple and Low Noise
- Low Quiescent Current
- Minimum Number of External Components
- SOT-89 and SOT-23 Small Package

**STANSON TECHNOLOGY**

120 Bentley Square, Mountain View, Ca 94040 USA
TEL: (650) 9389294 FAX: (650) 9389295

TYPICAL APPLCTUON CIRCUIT

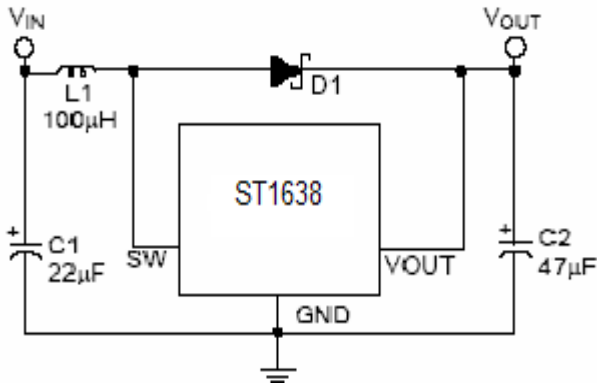

TEST CIRCUITS

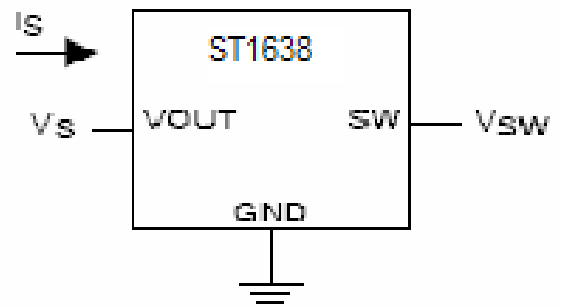
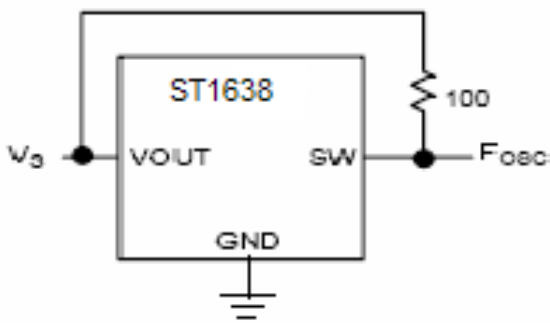

PIN DESCRIPTION

Pin	Symbol	Descripton
1	GND	Ground
2	VOUT	Output Voltage
3	SW	Switch Voltage



STANSON TECHNOLOGY

120 Bentley Square, Mountain View, Ca 94040 USA

TEL: (650) 9389294 FAX: (650) 9389295

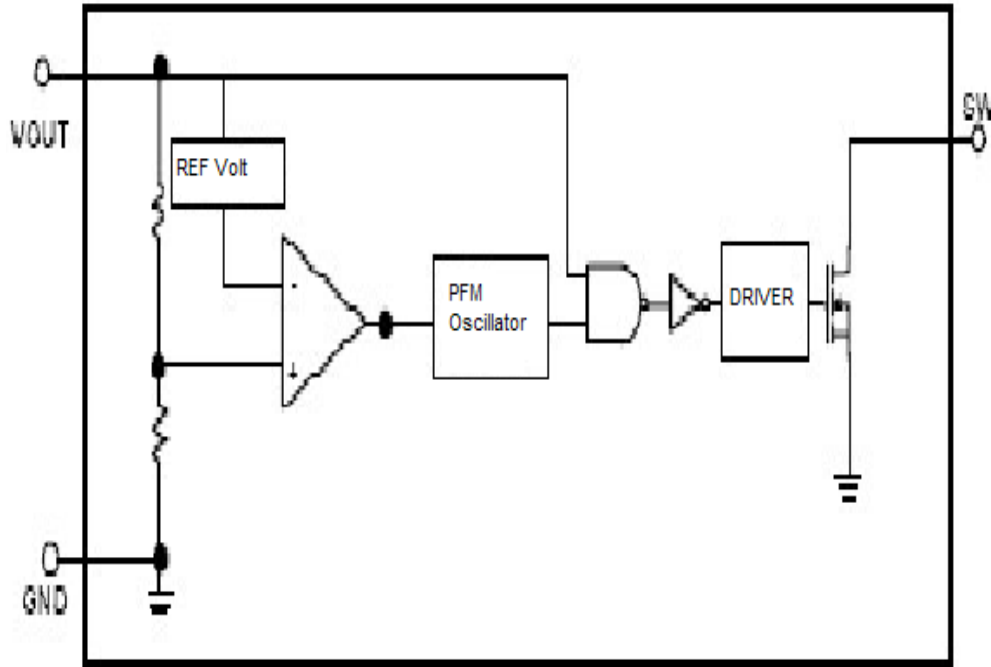
BLOCK DIAGRAM**ORDERING INFORMATION**

Part Number	Package	Part Marking
ST1638-XXS89	SOT-89	ST1638
ST1638-XXS23	SOT-23	1638

XX: Output Voltage Tape Reel; Pb – Fr

**STANSON TECHNOLOGY**

120 Bentley Square, Mountain View, Ca 94040 USA

TEL: (650) 9389294 FAX: (650) 9389295

High Efficiency PFM

ABSOLUTE MAXIMUM RATINGS ($T_a=25$, unless otherwise specified.)

The following ratings designate persistent limits beyond which damage to the device may occur.

Symbol	Parameter	Value	Unit
V_{OUT}	DC Supply Voltage	6	V
V_{SW}	SW Pin Voltage	6	V
I_{SW}	Switching Current	0.6	A
P_d	Power Dissipation @ $T_a=25$ * SOT-89 SOT-23	0.5 0.25	W
P_j	Operating Junction Temperature Range	-40 to 85	
T_{stg}	Storage Temperature Range	-65 to 150	
T_{lead}	Lead Soldering Temperature for 10 sec	SOT-89 SOT-23	260 220
R_{jc}	Thermal Resistance Junction-Case(*)	SOT-89 SOT-23	100 95

(*)The power dissipation and thermal resistance are evaluated under copper board mounted with free air conditions.

**STANSON TECHNOLOGY**

120 Bentley Square, Mountain View, Ca 94040 USA

TEL: (650) 9389294 FAX: (650) 9389295

High Efficiency PFM

ELECTRICAL CHARACTERISTICS ($T_a=25^\circ\text{C}$, $V_{CC}=15\text{V}$, unless otherwise specified.)

Symbol	Parameter	Conditions	Min.	Typ.	Max.	Unit
V_{OUT}	Output Voltage Accuracy		-2.5		2.5	%
I_{IN}	Input Voltage				6	V
V_{START}	Start Up Voltage	$I_{OUT} = 1\text{ mA}$, $V_{IN}: 0\text{--}2\text{V}$		0.8	0.9	V
V_{HOLD}	Hold On Voltage	$I_{OUT} = 1\text{ mA}$, $V_{IN}: 2\text{--}0\text{V}$	0.7			V
I_{IN}	Input Current at No Load	$I_{OUT} = 0\text{ mA}$		15		μA
I_{S1}	Supply Current	$V_S = V_{OUT} \times 0.95$	20		70	μA
I_{S2}	Supply Current	$V_S = V_{OUT} + 0.5\text{V}$		9		μA
R_{ON}	SW Switch-On Resistance	$V_S = V_{OUT} \times 0.95$, $V_{SW} = 0.4\text{V}$	1		1.3	
$I_{LEAKAGE}$	SW Leakage Current	$V_{SW} = 6\text{V}$			0.5	μA
F_{OSC}	Max Oscillator Freq.	$V_S = V_{OUT} \times 0.95$	80	120	160	KHz
D_{OSC}	Oscillator Duty Cycle	$V_S = V_{OUT} \times 0.95$	65	75	85	%
	Efficiency			85		%

**STANSON TECHNOLOGY**

120 Bentley Square, Mountain View, Ca 94040 USA

TEL: (650) 9389294 FAX: (650) 9389295

SOT- 89 PACKAGE OUTLINE

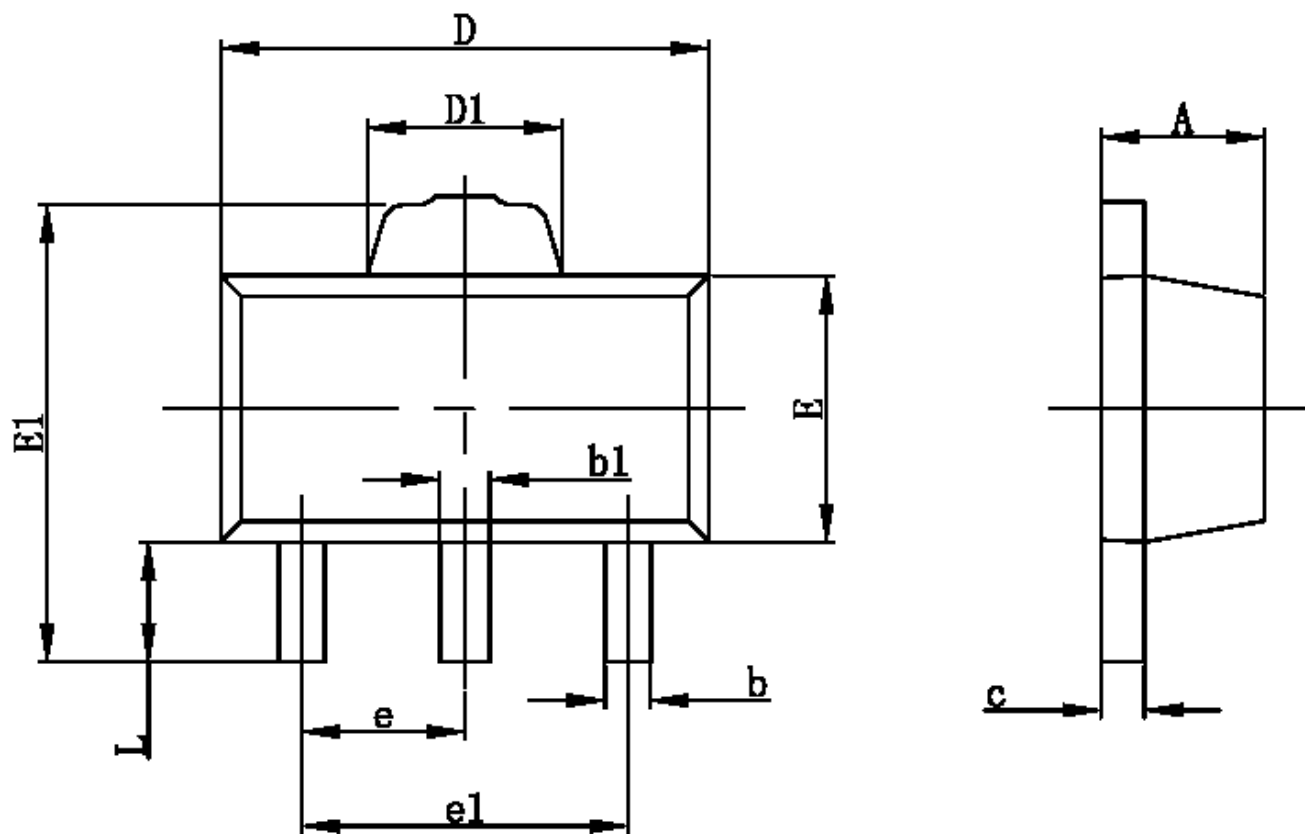

Symbol	Dimensions In Millimeters		Dimensions In Inches	
	Min	Max	Min	Max
A	1.400	1.600	0.055	0.063
b	0.320	0.520	0.013	0.020
b1	0.360	0.560	0.014	0.022
c	0.350	0.440	0.014	0.017
D	4.400	4.600	0.173	0.181
D1	1.400	1.800	0.055	0.071
E	2.300	2.600	0.091	0.102
E1	3.940	4.250	0.155	0.167
e	1.500TYP		0.060TYP	
e1	2.900	3.100	0.114	0.122
L	0.900	1.100	0.035	0.043

**STANSON TECHNOLOGY**

120 Bentley Square, Mountain View, Ca 94040 USA

TEL: (650) 9389294 FAX: (650) 9389295

300mA Driving Capability

SOT-23-3L PACKAGE OUTLINE

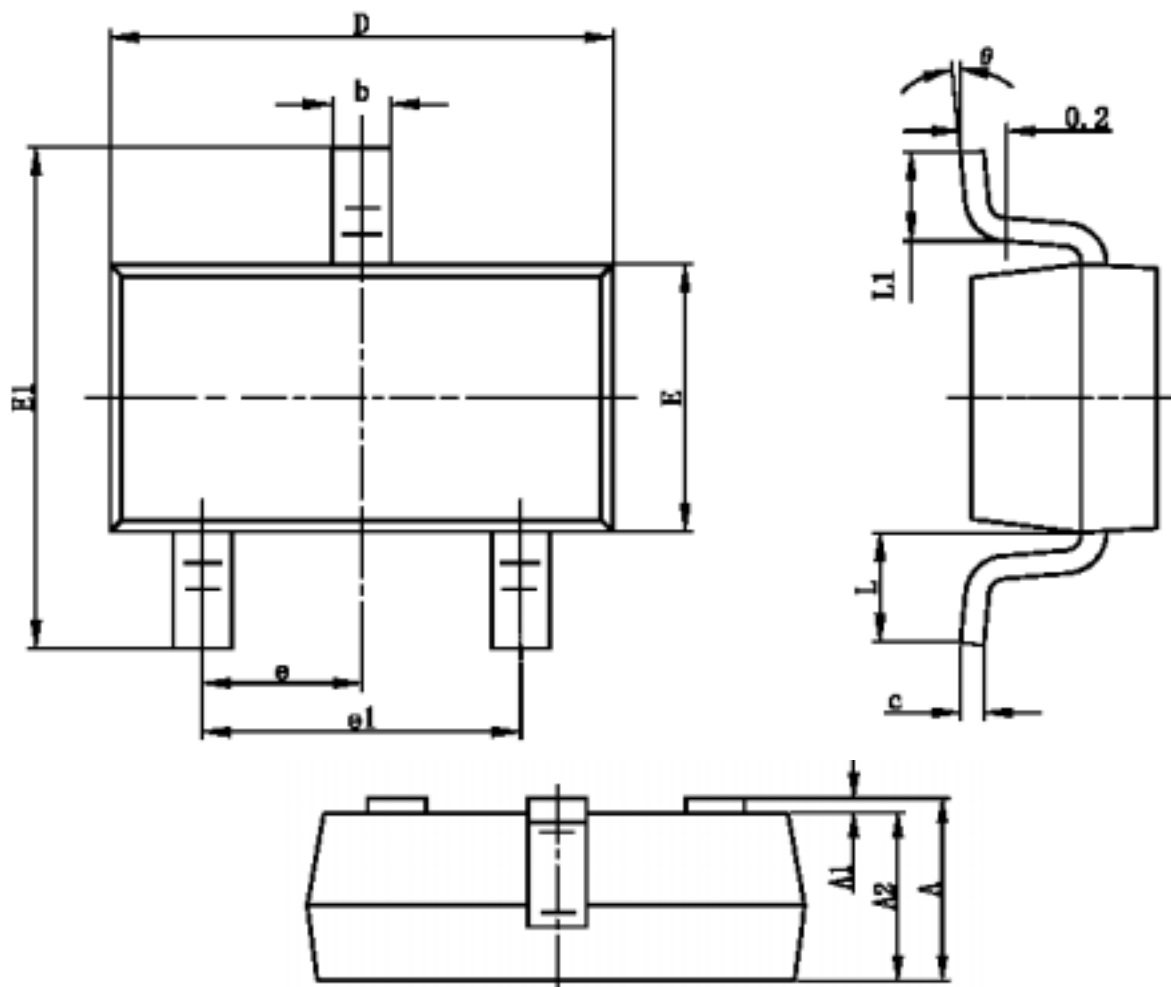

Symbol	Dimensions In Millimeters		Dimensions In Inches	
	Min	Max	Min	Max
A	1.050	1.250	0.041	0.049
A1	0.000	0.100	0.000	0.004
A2	1.050	1.150	0.041	0.045
b	0.300	0.400	0.012	0.016
c	0.100	0.200	0.004	0.008
D	2.820	3.020	0.111	0.119
E	1.500	1.700	0.059	0.067
E1	2.650	2.950	0.104	0.116
e	0.950TYP		0.037TYP	
e1	1.800	2.000	0.071	0.079
L	0.700REF		0.028REF	
L1	0.300	0.600	0.012	0.024
θ	0°	8°	0°	8°

**STANSON TECHNOLOGY**

120 Bentley Square, Mountain View, Ca 94040 USA

TEL: (650) 9389294 FAX: (650) 9389295