



TS4266G

Preliminary

150mA Ultra Low Drop Out Voltage Regulator with Inhibit

SOT-223-4L



Pin assignment:

1. Input
2. Inhibit
3. Output
4. Ground

High Input Voltage up to 45V
Low Dropout Voltage 0.5V (max)
Low Power Consumption 40uA (typ)

General Description

TS4266G is a 5V low-drop fixed-voltage regulator in an SOT-223-4L package. It can be switched ON and OFF by the Inhibit pin. It is functional and pin compatible to the TS4266, but with a reduced quiescent current of <math><1\mu\text{A}</math> in OFF mode and 40uA in ON mode. The TS4266G is especially designed for all applications that require very low quiescent current in ON and OFF mode. It is designed to supply microprocessor systems under the sever condition of automotive applications and therefore it is equipped with additional protection against over load, short circuit and over temperature. TS4266G also can be used in other applications, where a stabilized voltage and the inhibit feature is required. The IC regulates an input voltage in the range of $5.5\text{V} < V_{in} < 45\text{V}$ to $V_{out}(\text{rated}) = 5.0\text{V}$. The maximum output current is more than 150mA. This IC is regulated at the inhibit pin pull high level voltage.

Features

- ◇ Fixed output voltage 5V
- ◇ Output voltage tolerance +/-3 %
- ◇ 150mA current capability
- ◇ Ultra low drop out voltage
- ◇ Very low current consumption 40uA (typ)
- ◇ Over temperature protection
- ◇ Short-circuit proof
- ◇ Reverse polarity proof
- ◇ Wide temperature range
- ◇ Suitable for use in automotive electronics
- ◇ Inhibit control

Ordering Information

Part No.	Operating Temp.	Package
TS4266GCW450	-40 ~ 150 °C	SOT-223-4L

Pin Definition and Function

Pin	Symbol	Function
1	Input	Block to ground directly on IC with ceramic capacitor
2	Inhibit	Inhibit input, high level turn IC on
3	Output	Block to ground with 10uF capacitor, ESR <math><4\Omega</math>
4	Ground	Ground

Block Diagram

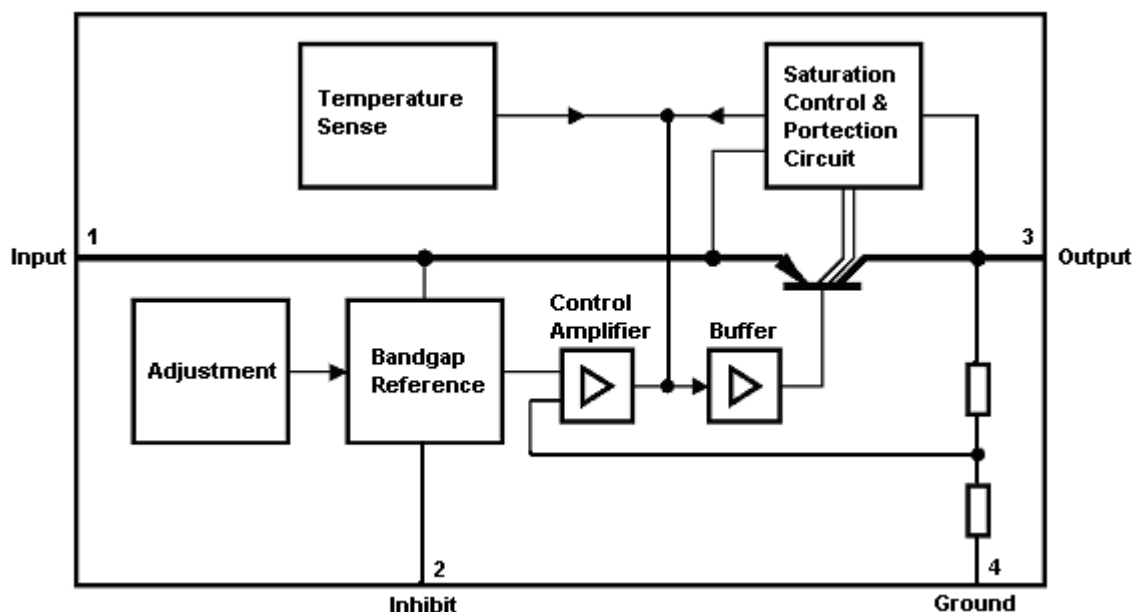



Absolute Maximum Rating					
Parameter	Symbol	Values	Unit		
Input Supply Voltage	V _{in}	-42 ~ 45	V		
Inhibit Supply Voltage	V _{inhibit}	-42 ~ 45	V		
Operating Input Voltage	V _{in(opr)}	5.5 ~ 45	V		
Output Voltage	V _{out}	-1 ~ 32	V		
Power Dissipation	P _D	Internally Limited	W		
Ground Current	I _{GND}	50	mA		
Operating Junction Temperature Range	T _J	-40 ~ +150	°C		
Storage Temperature Range	T _{STG}	-50 ~ +150	°C		
Thermal Performance					
Parameter	Symbol	Values	Unit		
Junction to Ambient	R _{θja}	81	°C/W		
Junction to Case	R _{θjc}	18			
Electrical Characteristics					
V _{in} = 13.5V, V _{inhibit} = 5V, -40 ≤ T _j ≤ +150, unless otherwise specified.					
Parameter	Conditions	Min	Typ	Max	Unit
Output Voltage	6V ≤ V _{in} ≤ 21V, 5mA ≤ I _o ≤ 100mA	4.85	5.0	5.15	V
Output Voltage	6V ≤ V _{in} ≤ 16V, 5mA ≤ I _o ≤ 50mA	4.90	5.0	5.10	V
Output Current Limited		150	--	--	mA
Line Regulation	6V ≤ V _{in} ≤ 28V, I _o = 1mA	--	15	30	mV
Load Regulation	1mA ≤ I _o ≤ 100mA, V _{in} = 6V	--	50	90	mV
Dropout Voltage (note 1)	I _o = 100mA	--	0.25	0.5	V
Current Consumption (I _q = I _{in} – I _{out})	V _{inhibit} = 0V, T _j ≤ 100°C	--	0	1	
	I _o = 100uA	--	40	70	uA
	I _o = 50mA	--	1.7	4	mA
Power Supply Ripple Rejection	f = 100Hz, V _r = 0.5Vp-p	--	68	--	dB
Inhibit					
Inhibit ON Voltage		3.5	--	--	V
Inhibit OFF Voltage		--	--	0.8	V
Inhibit Current	V _{inhibit} = 5V	--	4	8	uA
Pull Down Resistor	See Inhibit Current	--	1.0	--	MΩ

Note 1: Drop voltage = V_{in} – V_{out}
(measured where V_{out} has dropped 100mV from the nominal value obtained at V_{in} = 13.5V)

Typical Application Circuit

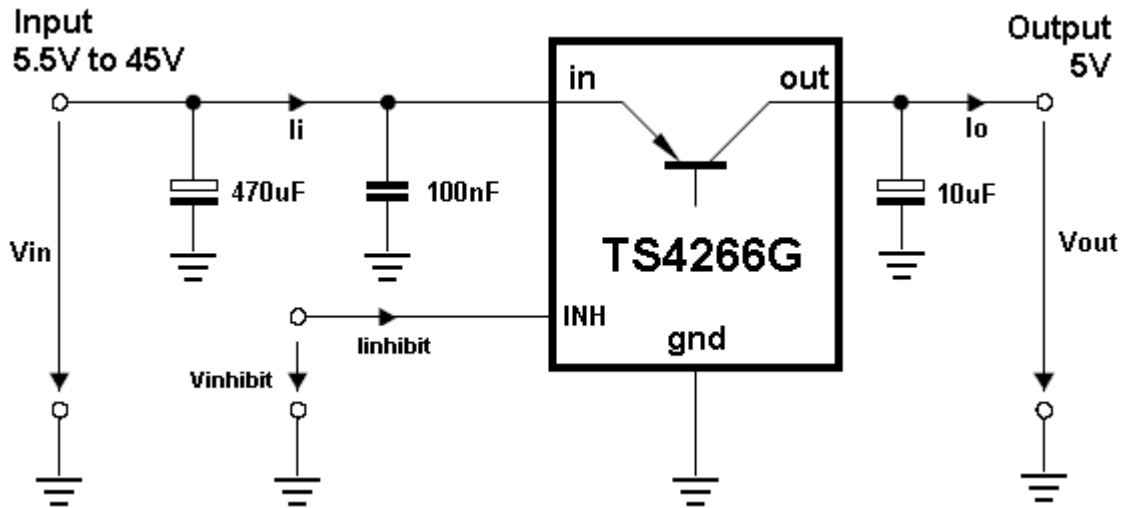

Application Information

Dimensioning Information on External Components

The input capacitor C_{in} is necessary for compensating line influences (100nF ceramic capacitor recommended). Using a resistor of approx. 1Ω in series with C_{in} , the oscillating of input inductivity and input capacitance can be clamped. In the application circuit shown, an additional electrolytic input capacitor of 470uF is added in order to buffer supply line influences. This capacitor is recommended, if the device is sourced via long supply lines of several meters.

The output capacitor C_{out} is necessary for the stability of the regulating circuit. Stability is guaranteed at values $C_{out} \geq 10\mu F$ and an $ESR \leq 4\Omega$ within the operating temperature range.

Circuit Description

The control amplifier compares a reference voltage of 2.5V typical, the regulation loop controls the output to achieve an output voltage of 5V with an accuracy of $\pm 2\%$ at an input voltage up to 45V. The minimum required input voltage is $V_{out} + V_{drop}$.

The TS4266G can supply up to 150mA. However for protection reasons at high input voltage above 25V, the maximum output current is reduced (SOA protection). The IC is additionally protected against overload, over temperature and reverse polarity

SOT-223-4L Mechanical Drawing

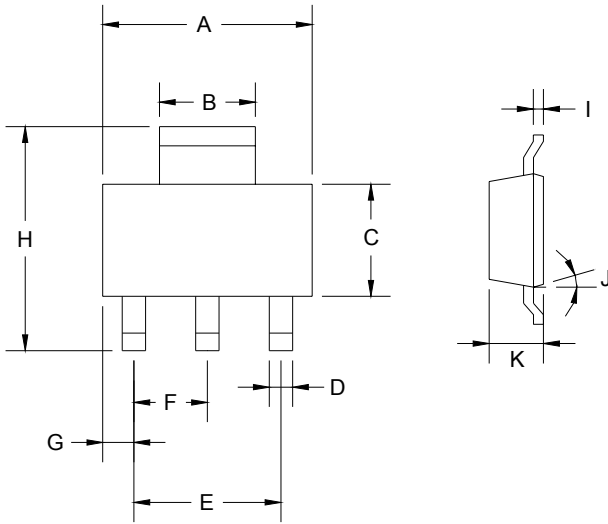

DIM	SOT-223-4L DIMENSION			
	MILLIMETERS		INCHES	
	MIN	MAX	MIN	MAX
A	6.350	6.850	0.250	0.270
B	2.900	3.100	0.114	0.122
C	3.450	3.750	0.136	0.148
D	0.595	0.635	0.023	0.025
E	4.550	4.650	0.179	0.183
F	2.250	2.350	0.088	0.093
G	0.835	1.035	0.032	0.041
H	6.700	7.300	0.263	0.287
I	0.250	0.355	0.010	0.014
J	10°	16°	10°	16°
K	1.550	1.800	0.061	0.071