

UTC TA2003 LINEAR INTEGRATED CIRCUIT

AM/FM RADIO IC

DESCRIPTION

The UTC TA2003 is AM/FM Radio IC (FM F/E + AM/FM IF) which is designed for AM/FM Radios.

FEATURES

- * FM IFT, AM IFT and FM Detector Coil aren't needed.
- * Operating Supply Voltage Range
- * VCC(opr) = 1.8 ~ 7V (Ta=25°C).

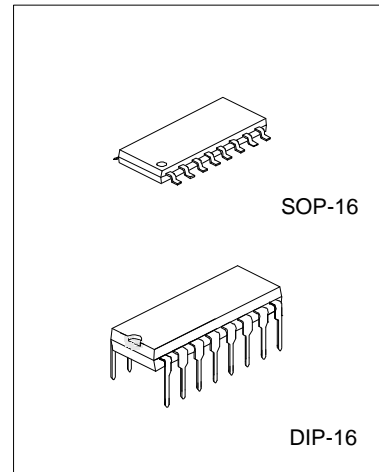

BLOCK DIAGRAM

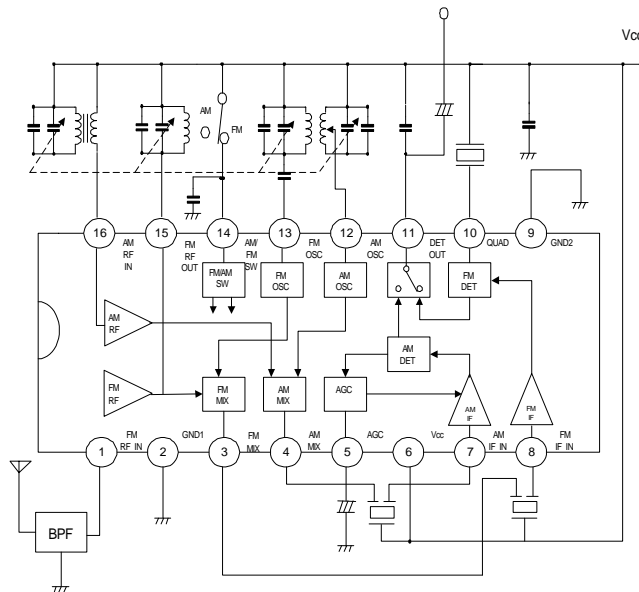

UTC TA2003 LINEAR INTEGRATED CIRCUIT

EXPLANATION OF TERMINAL

TERMINAL VOLTAGE : Typical DC voltage at Ta=25°C, Vcc=3V and no signal with Test Circuit

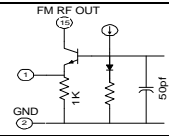
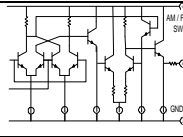
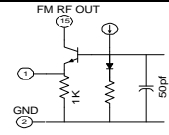
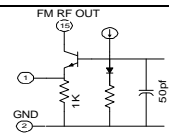
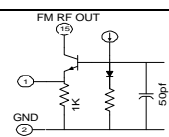
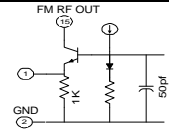
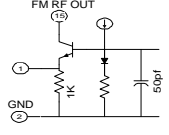
NO	SYMBOL	CONTENTS	INTERNAL CIRCUIT	TERMINAL VOLTAGE	
				AM	FM
1	FM AF IN	Input of FM RF Amplifier		0	0.7
2	GND1	GND for RF, DSC and MIX Stage	-	0	0
3	FM MIX	Output of FM MIX		0.4	1.7
4	AM MIX	Output of AM MIX		0.6	0
5	AGC	By pass of AM AGC		0	0
6	Vcc	-	-	3.0	3.0
7	AM IF IN	Input of AM IF Amplifier		3.0	3.0
8	FM IF IN	Input of FM IF Amplifier		3.0	3.0
9	GND2	GND for IF stage	-	0	0
10	QUAD	FM QUAD Detector Ceramic Discriminator is connected. Recommendation CDA 10.7MG31 (MURATA MFG. CO., LTD)		2.5	2.2

UTC TA2003 LINEAR INTEGRATED CIRCUIT

NO	SYMBOL	CONTENTS	INTERNAL CIRCUIT	TERMINAL VOLTAGE	
				AM	FM
11	DET OUT	Output of FM/AM Detector		1.4	1.1
12	AM OSC	AM local Oscillator Terminal Oscillator Coil is connected.		3.0	3.0
13	FM OSC	FM local Oscillator Terminal Oscillator Coil is connected		0.9	3.0
14	AM/FM SW	AM/FM switch connected to Pin14 Vcc->FM mode Pin14 OPEN->AM mode		0.9	3.0
15	FM RF OUT	FM RF Coil is conected	cf. PIN 1	3.0	3.0
16	AM RF IN	input of AM RF Amplifier		3.0	3.0

UTC TA2003 LINEAR INTEGRATED CIRCUIT

ABSOLUTE MAXIMUM RATINGS (Ta=25°C)

PARAMETER		SYMBOL	VALUE	UNITS
Supply Voltage		Vcc	8	V
Power Dissipation	DIP-16	PD(Note)	750	mW
	SOP-16		350	
Operating Temperature		Topr	-25~75	°C
Storage Temperature		Tstg	-55~150	°C

ELECTRICAL CHARACTERISTICS

Unless otherwise specified, Ta=25°C, VCC=3V, FE : f = 98MHz, fm = 1KHz
 FM IF : f = 10.7MHz, fm = 1KHz
 AM : f = 1MHz, MOD = 30%, fm = 1 KHz

PARAMETER		SYMBOL	TEST CIRC-UIT	TEST CONDITIONS	MIN	TYP	MAX	UNIT
Supply Current		Icc (FM)	1	FM Mode, Vin=0	-	10.5	16.5	mA
		Icc (AM)	1	AM Mode, Vin=0	-	5.0	8.0	
F/E	Input Limiting Voltage	Vin(lim)	1	-3dB limiting point	-	12	-	dB V EMF
	Quiescent Sensitivity	Qs	1	S/N=30dB	-	12	-	dB V EMF
	Local OSC Voltage	Vosc	2	fosc=108MHz	160	240	320	mVrms
	Local OSC Stop Voltage	Vstop(FM)	2	Vin=0	-	1.2	-	V
FM IF	Input Limiting Voltage	Vin(lim) IF	1	-3dB limiting point	42	47	52	dB V EMF
	Recovered Output Voltage	VOD	1	Vin=80dB V EMF	50	70	90	mVrms
	Signal To Noise Ratio	S/N	1	Vin=80dB V EMF	-	62	-	dB
	Total Harmonic Distortion	THD	1	Vin=80dB V EMF	-	0.4	-	%
AM	AM Rejection Ratio	AMR	1	Vin=80dB V EMF	-	33	-	dB
	Voltage Gain	Gv	1	Vin=27dB V EMF	15	32	50	mVrms
	Recovered Output Voltage	VOD	1	Vin=60dB V EMF	35	60	85	mVrms
	Signal To Noise Ratio	S/N	1	Vin=60dB V EMF	-	43	-	dB
	Total Harmonic Distortion	THD	1	Vin=60dB V EMF	-	1.0	-	%
	Local DSC Stop Voltage	Vstop (AM)	1	Vin=0	-	1.6	-	V

COIL DATA (Test circuit)

COIL NO.	TEST FREQ (Hz)	L (mH)	Co (pF)	Qo	TURNS					WIRE
					1-2	2-3	1-3	1-4	4-6	
L1 FM RF	100M	-	-	100	-	-	-	2.25	-	0.5 UEW
L2 FM OSC	100M	-	-	100	-	-	1.75	-	-	0.5 UEW
L3 AM OSC	796K	26B	-	125	14	86	-	-	-	0.06 UEW

UTC TA2003 LINEAR INTEGRATED CIRCUIT

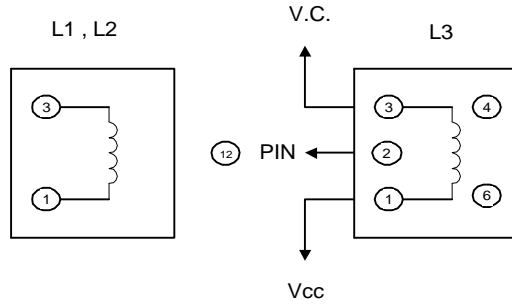

TEST CIRCUIT 1

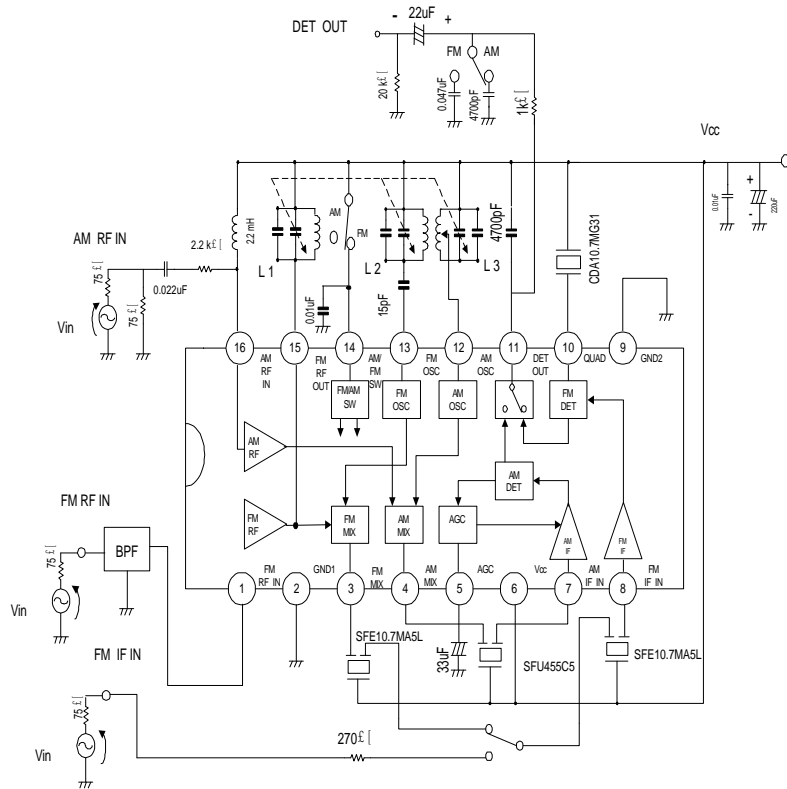

UTC TA2003 LINEAR INTEGRATED CIRCUIT

TEST CIRCUIT 2

