

POWER MANAGEMENT

Description

The SC604A is a very high efficiency charge pump white LED driver from the mAhXLife™ family of products, optimized for Li-Ion battery applications.

The four (4) LED outputs are current matched for consistent LED brightness. Extremely low battery current is achieved by automatically reconfiguring the charge pump to match circuit conditions. Using four LEDs, each at 20mA for a total $I_{OUT} = 80mA$, the SC604A can use less than 83mA from the supply for most of the battery life.

Patented low noise mode switching circuitry and constant output current allow the use of extremely small input and output capacitors.

Features

- ◆ Very high efficiency over 90% of battery life
- ◆ Peak efficiency over 92%
- ◆ Current regulation for up to 4 LEDs
- ◆ Digital 3 bit output control logic
- ◆ Current matching tolerance of $\pm 3\%$ typical
- ◆ Wide current range per LED [0.5mA - 30mA]
- ◆ High available total LED current = $4 \cdot I_{LED} = 120mA$
- ◆ Low Shutdown Current: 1 μA typical
- ◆ Soft start / In-rush current limiting
- ◆ Short circuit protection
- ◆ MLP-16 [4x4] Package
- ◆ Fixed frequency 250kHz
- ◆ 1x, 1.5x and 2x charge pump modes of operation

Applications

- ◆ Cellular phones
- ◆ LED backlighting
- ◆ PDA power supplies
- ◆ Portable devices
- ◆ Electronic books
- ◆ Wireless web appliances
- ◆ LCD Modules

Typical Application Circuit

Patent Pending

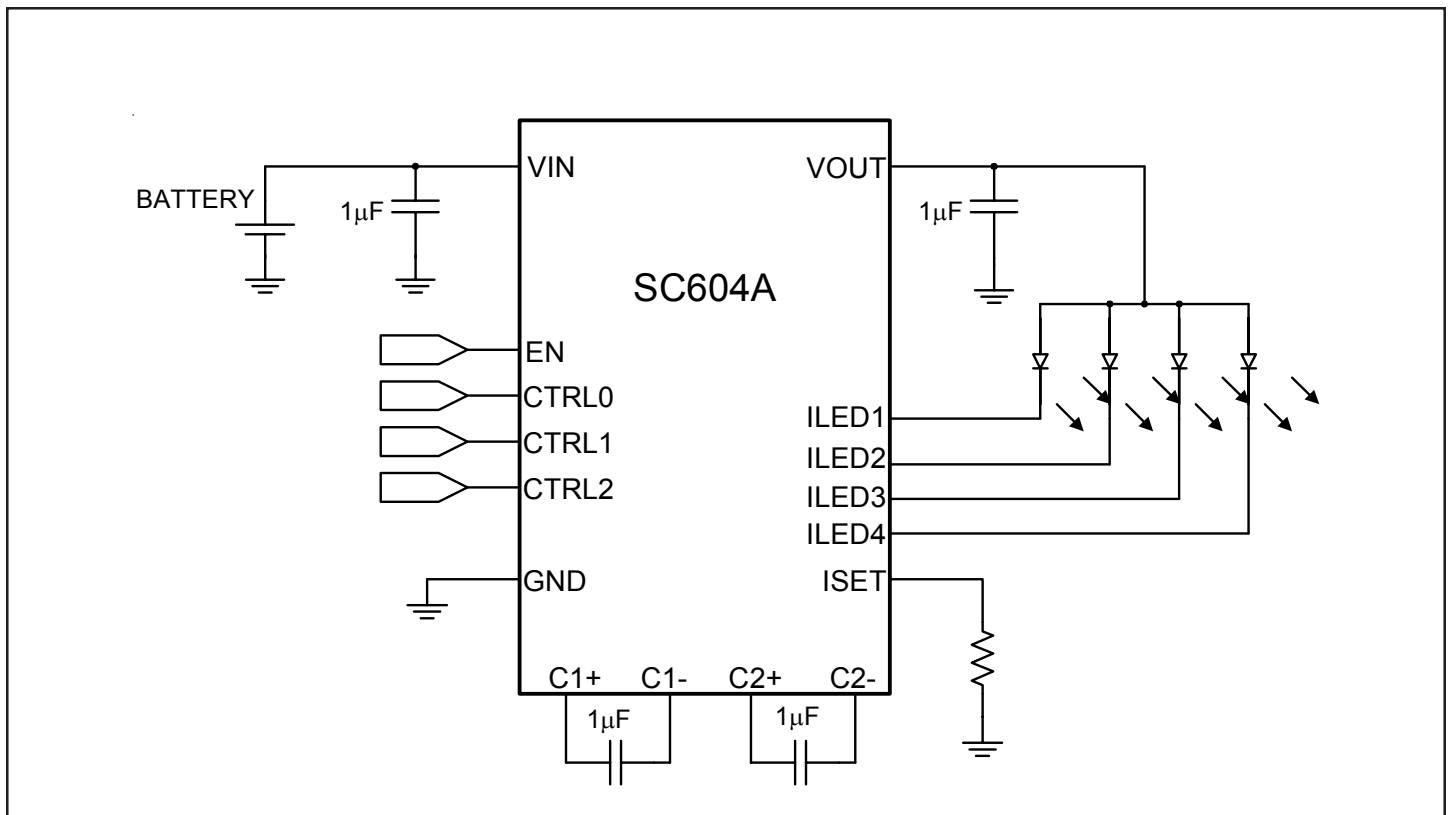

POWER MANAGEMENT
Absolute Maximum Ratings

Exceeding the specifications below may result in permanent damage to the device, or device malfunction. Operation outside of the parameters specified in the Electrical Characteristics section is not implied.

Parameter	Symbol	Maximum	Units
Supply Voltage	V _{IN}	-0.3 to +7.0	V
Output Voltage	V _{OUT}	-0.3 to +7.0	V
V _{OUT} Short Circuit Duration	SC	Indefinite	s
Thermal Resistance, Junction to Ambient ⁽¹⁾	θ _{JA}	40	°C/W
Operating Ambient	T _A	-40 to +85	°C
Junction Temperature Range	T _J	-40 to +150	°C
Storage Temperature Range	T _{STG}	-65 to +150	°C
IR Reflow Temperature SC604AIMLTR	T _{LEAD}	240	°C
IR Reflow Temperature SC604AIMLTRT	T _{LEAD}	260	°C

Note: (1) By JE51 standards

Electrical Characteristics

Unless specified: T_A = -40°C to 85°C, V_{IN} = 2.85V to 5.5V, C1 = C2 = 1.0μF (ESR = 0.03Ω). Typical values @ T_A = 25°C, LED V_F = 3.4V.

This device is ESD sensitive. Use of standard ESD handling precautions is required.

Parameter	Symbol	Conditions	Min	Typ	Max	Units
Input Supply Voltage	V _{IN}		2.5		6.5	V
Current into LEDs 1, 2, 3 and 4	I _{LED}	R _{SET} = 24.0kΩ		20		mA
		R _{SET} = 94.0kΩ		5.0		mA
		2.7V < V _{IN} < 5.5V	0.5		20	mA
		3.1V < V _{IN} < 5.5V	0.5		30	mA
Quiescent Current	I _Q	I _{OUT} = 5mA		1500	2000	μA
		Enable = 0V		1	7	μA
I _{LED} Accuracy	I _{LED-ERR}	0.5mA ≤ I _{LED} ≤ 30mA		± 5		%
Current Matching	I _{LED-LED-ERR}	0.5mA ≤ I _{LED} ≤ 30mA		± 3		%
1x mode to 1.5x mode transition voltage (V _{IN} falling)	V _{TRANS1X}	V _{LED} = 3.6V, I _{OUT} = 80mA, I _{LED} = 20mA		3.796		V
1.5x mode to 2x mode transition voltage (V _{IN} falling)	V _{TRANS1.5X}	V _{LED} = 3.6V, I _{OUT} = 80mA, I _{LED} = 20mA		3.320		V
Oscillator Frequency	f _{OSC}		212.5	250	287.5	kHz
Output Over Voltage Protection ⁽¹⁾	V _{OVF}	Open circuit at any LED that is programmed to be in the On state	5.0			V

POWER MANAGEMENT
Electrical Characteristics (Cont.)

Unless specified: $T_A = -40^\circ\text{C}$ to 85°C , $V_{IN} = 2.85\text{V}$ to 5.5V , $C1 = C2 = 1.0\mu\text{F}$ (ESR = 0.03Ω). Typical values @ $T_A = 25^\circ\text{C}$, LED $V_F = 3.4\text{V}$.

Parameter	Symbol	Conditions	Min	Typ	Max	Units
Input Current Limit	ILIMIT	Short circuit applied from VOUT to GND		220	850	mA
Input High Threshold	V_{IH}	Input high logic threshold	1.3			V
Input Low Threshold	V_{IL}	Input low logic threshold			0.4	V
Input High Current	I_{IH}	$V_{IH} = V_{IN}$			10	μA
Input Low current	I_{IL}	$V_{IL} = \text{GND}$			10	μA

Notes:

(1) Guaranteed by design

POWER MANAGEMENT
Definitions
I_{LED} Accuracy

The LED current is determined by the R_{SET} resistor (I_{LED} vs. R_{SET} data is found on pages 9 and 10). This term does not include the tolerance of the resistor R_{SET}. If maximum accuracy is required, a precision resistor is needed. To calculate the error I_{LED-ERR} [%], use the formula

$$I_{LED-ERR} [\%] = \pm \left(\frac{(I_{LED})_{MEASURED} - I_{LED}}{I_{LED}} \right) \cdot 100\%$$

Current Matching

Current Matching refers to the difference in current from one LED to the next. The ΔI between any two LEDs will meet this requirement. To calculate the error I_{LED-LED-ERR}, first identify the highest and lowest value of the 4 LED currents, and use the formula:

$$I_{LED-LED-ERR} [\%] = \left(\frac{\frac{I_{MAX}}{I_{MAX} + I_{MIN}} - 1}{2} \right) \cdot 100\%$$

or

$$\left(\frac{\frac{I_{MIN}}{I_{MAX} + I_{MIN}} - 1}{2} \right) \cdot 100\%$$

which reduces to ±

$$\left(\frac{I_{MAX} - I_{MIN}}{I_{MAX} + I_{MIN}} \right) \cdot 100\%$$

1x Mode, 1.5x Mode and 2x Mode

1x Mode, 1.5x Mode and 2x Mode all refer to the charge pump configuration. These modes boost the battery input voltage and ensure there is enough voltage at V_{OUT} so that the regulated current will flow through the LEDs and return via the I_{LED} pins.

Input Current

The total input current of the SC604A is a function of the sum of the LED currents, the charge pump mode and the quiescent current. The quiescent current trend is charted on page 12 and used to calculate I_{IN} in the following examples.

$$I_{IN} = I_{OUT} \cdot Mode + I_Q =$$

$$(I_{LED1} + I_{LED2} + I_{LED3} + I_{LED4}) \cdot Mode + I_Q$$

Example 1:

$$Mode = 1x, I_Q = 2.4mA,$$

$$I_{LED1} + I_{LED2} + I_{LED3} + I_{LED4} = 4 \cdot 15mA = 60mA$$

Answer 1:

$$I_{IN} = I_{OUT} \cdot Mode + I_Q = 60mA \cdot 1 + 2.4mA = 62.4mA$$

Example 2:

$$Mode = 1.5x, I_Q = 2.4mA,$$

$$I_{LED1} + I_{LED2} + I_{LED3} + I_{LED4} = 4 \cdot 15mA = 60mA$$

Answer 2:

$$I_{IN} = I_{OUT} \cdot Mode + I_Q = 60mA \cdot 1.5 + 2.4mA = 92.4mA$$

Mode Transition Voltage

Mode transition voltage refers to the input voltage at the point just before the charge pump changes from a weaker mode to a stronger mode. V_{TRANS1X} is the transition from 1x to 1.5x mode, and V_{TRANS1.5X} is the transition from 1.5x to 2x mode. Equations for V_{TRANS1X} and V_{TRANS1.5X} are given on page 7.

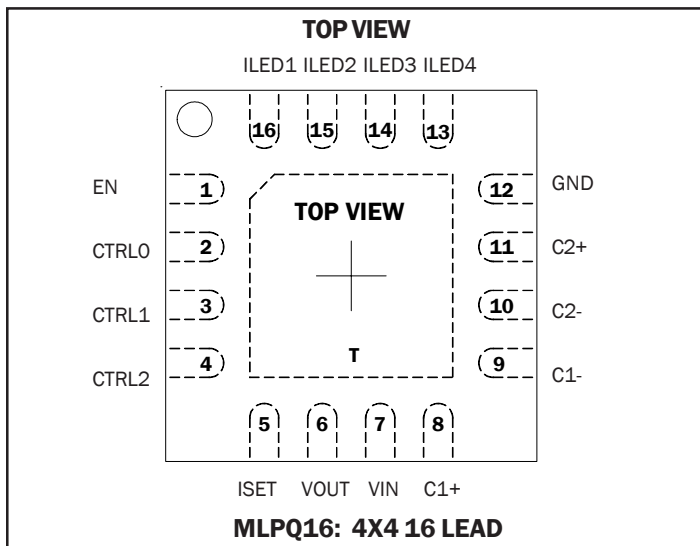
POWER MANAGEMENT
Pin Configuration

Ordering Information

DEVICE	PACKAGE ⁽¹⁾
SC604AIMLTR	MLP-16
SC604AIMLTRT ⁽²⁾	MLP-16
SC604EVB	Evaluation Board

Notes:

(1) Available in tape and reel only. A reel contains 3000 devices.

(2) Available in lead-free package only. This product is fully WEEE and RoHS compliant.

Pin Descriptions

Pin	Pin Name	Pin Function
1	EN	Active high enable
2	CTRL0	Output control bit 0 (see Table 1 on page 6)
3	CTRL1	Output control bit 1 (see Table 1 on page 6)
4	CTRL2	Output control bit 2 (see Table 1 on page 6)
5	ISET	LED current is set by the value of the resistor R_{SET} connected from the ISET pin to ground. Do not short the ISET pin. V_{ISET} is typically 1.22V
6	VOUT	Voltage output source for connection to the LED anodes
7	VIN	Voltage input
8	C1+	Positive terminal of bucket capacitor 1
9	C1-	Negative terminal of bucket capacitor 1
10	C2-	Negative terminal of bucket capacitor 2
11	C2+	Positive terminal of bucket capacitor 2
12	GND	Ground
13	ILED4	Current sink for LED 4 [If not in use, pin must be left open] ⁽¹⁾
14	ILED3	Current sink for LED 3 [If not in use, pin may be left open, grounded, or connected to V_{IN}] ⁽¹⁾
15	ILED2	Current sink for LED 2 [If not in use, pin may be left open, grounded, or connected to V_{IN}] ⁽¹⁾
16	ILED1	Current sink for LED 1 [If not in use, pin may be left open, grounded, or connected to V_{IN}] ⁽¹⁾
T	Thermal Pad	Pad for heatsinking purposes. Connect to ground plane using multiple vias. Not connected Internally

Note: (1) The CTRL word must match the outputs in use.

POWER MANAGEMENT

Block Diagram

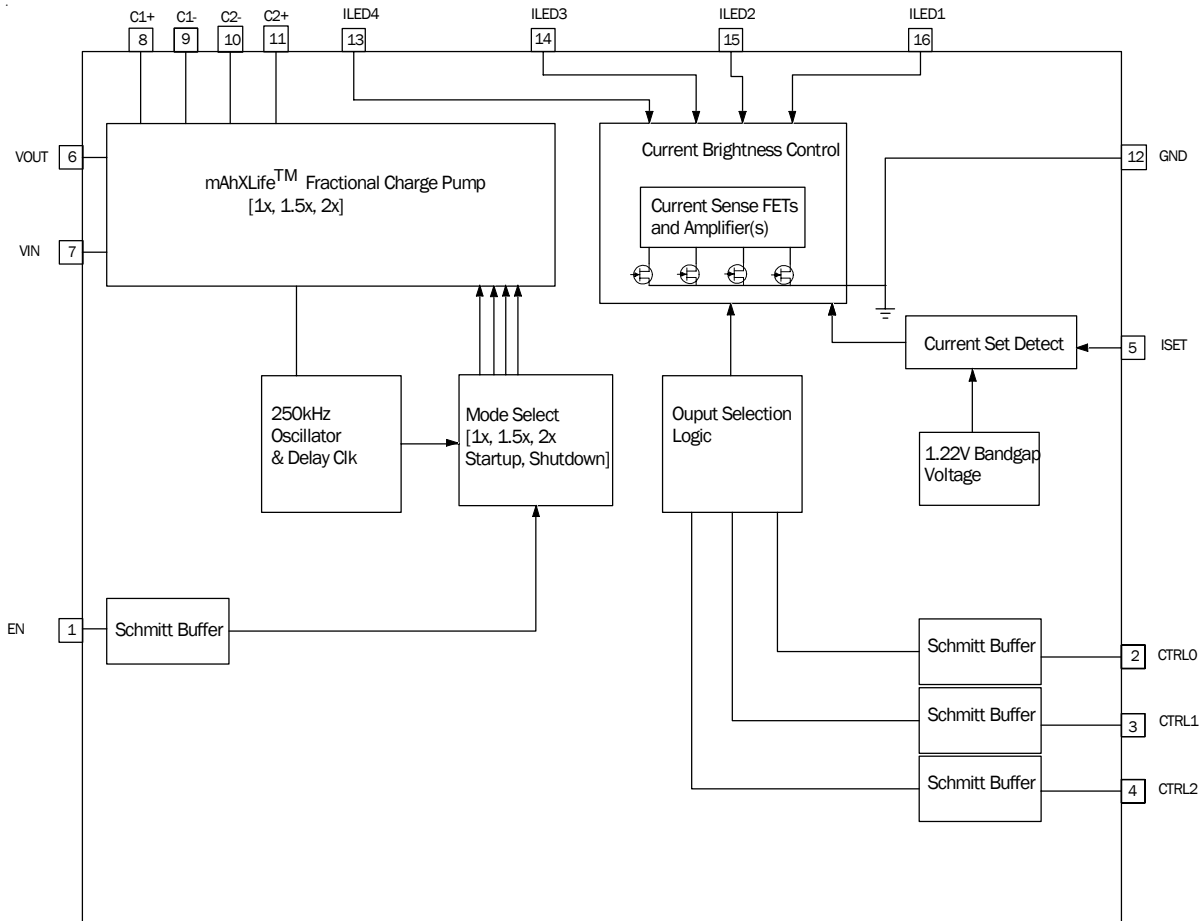

Table 1 - LED Enable Logic

Control Inputs ⁽¹⁾			Output Status			
CTRL2	CTRL1	CTRL0	LED4	LED3	LED2	LED1
0	0	0	OFF	OFF	OFF	ON
0	0	1	OFF	OFF	ON	OFF
0	1	0	OFF	ON	OFF	OFF
0	1	1	ON	OFF	OFF	OFF
1	0	0	OFF	OFF	ON	ON
1	0	1	OFF	ON	ON	ON
1	1	0	ON	ON	ON	ON
1	1	1	OFF	OFF	OFF	OFF

Notes:
 (1) The sequencing of Enable and logic state CTRL{2,1,0} = [1, 1, 1] will affect quiescent state current. $I_q = 100\mu A$ if Enable transitions high before CTRL{2,1,0} transitions to [1, 1, 1]. $I_q = 400\mu A$ if Enable transitions high after CTRL{2,1,0} transitions to [1, 1, 1]. If Enable = high and CTRL{2,1,0} = [1, 1, 1] is to be used for an extended period of time, it is recommended that Enable = High when change to the [1, 1, 1] state to achieve the lower I_q level.

POWER MANAGEMENT
Applications Information
Detailed Description

The SC604A contains a fractional charge pump, mode selection circuit, output selection logic, current setting detection circuit, and four current sense circuits. All are depicted in the block diagram on page 6.

The fractional charge pump multiplies the input voltage a multiple of 1, 1.5 or 2 times the input voltage. The charge pump switches at a fixed 250kHz whenever the mode is 1.5x or 2x. The charge pump does not switch during 1x mode, saving power and improving efficiency.

The mode selection circuit automatically selects the mode as 1x, 1.5x or 2x based on circuit conditions such as LED voltage, input voltage and load current. 1x is the most efficient mode, followed by 1.5x and 2x modes. At lower voltages a stronger mode may be needed to maintain regulation, if so, the mode will change first to 1.5x and then to 2x. 2x mode usually operates for a much shorter run time compared to 1x mode, and 2x mode maintains the output until the battery is discharged to 2.85V or less. The LED requiring the highest voltage drop will determine the output voltage needed to drive all outputs with adequate bias. Comparing all cathodes and regulating VOUT for the LED with the lowest cathode voltage ensures sufficient bias for all LEDs.

Output selection logic enables control over the LED outputs for on and off functions with eight (8) different output states. The states are defined in Table 1 on page 6.

The current set and detection circuit uses an external resistor and a 1.22V reference to program the LED current.

Four (4) current regulating circuits sink matched currents from the LEDs. LEDs with matched forward voltage will produce the best possible matched currents. For best matching performance it is recommended that the ΔVf between LEDs be under 250mV. (For more information on ΔVf considerations refer to Semtech application notes).

Designing for Lowest Possible Battery Current

The SC604A efficiency and battery current are shown in the plots that follow on page 8. For this example, 4 LEDs are matched at 15mA each. The battery current remains low at 63mA well into the Li-Ion battery range as indicated in the plot by a boundary box. The SC604A uses 1x mode ($I_{IN}=I_{OUT}+I_Q$) for part of the input voltage range, conserving significant energy from the battery. A similar four (4) output device uses only 1.5x mode ($I_{IN}=I_{OUT} \cdot 1.5+I_Q$) over the input voltage range. This means that the SC604A will have about 25% higher efficiency than a 1.5x only charge pump. Where the competition drops off at 3V, the SC604A uses 2x mode to extend the operating range down to a battery voltage of only 2.85V.

The input voltages at which the mode transitions occur are dependent on the forward voltage V_F of the LED used and the LED current I_{LED} . To keep the battery current low and in the 1x mode for as long as possible, it is best to choose an LED with a lower V_F .

The mode transition voltages $V_{TRANS1X}$ and $V_{TRANS1.5X}$ can be estimated by the following equations:

$$V_{TRANS1X} = V_F + V_{ILED} + [(\# \text{ of LEDs used}) \cdot I_{LED} \cdot 1.2]$$

$$V_{TRANS1.5X} = \frac{V_F + V_{ILED} + [(\# \text{ of LEDs used}) \cdot I_{LED} \cdot 16]}{1.5}$$

where, V_F is the forward LED voltage measured from anode to cathode, V_{ILED} is the voltage at the ILED pin, typically $V_{ILED} = 100mV$, I_{LED} is the LED current.

Power efficiency can now be estimated for comparison with the intended battery voltage range.

$$\text{Efficiency [\%]} = \frac{V_{OUT} \cdot I_{OUT}}{V_{IN} \cdot (I_{OUT} \cdot \text{Mode} + I_Q)} \cdot 100\%$$

Battery Current Comparison for 4 LEDs at 15mA Each with LED = 3.5V

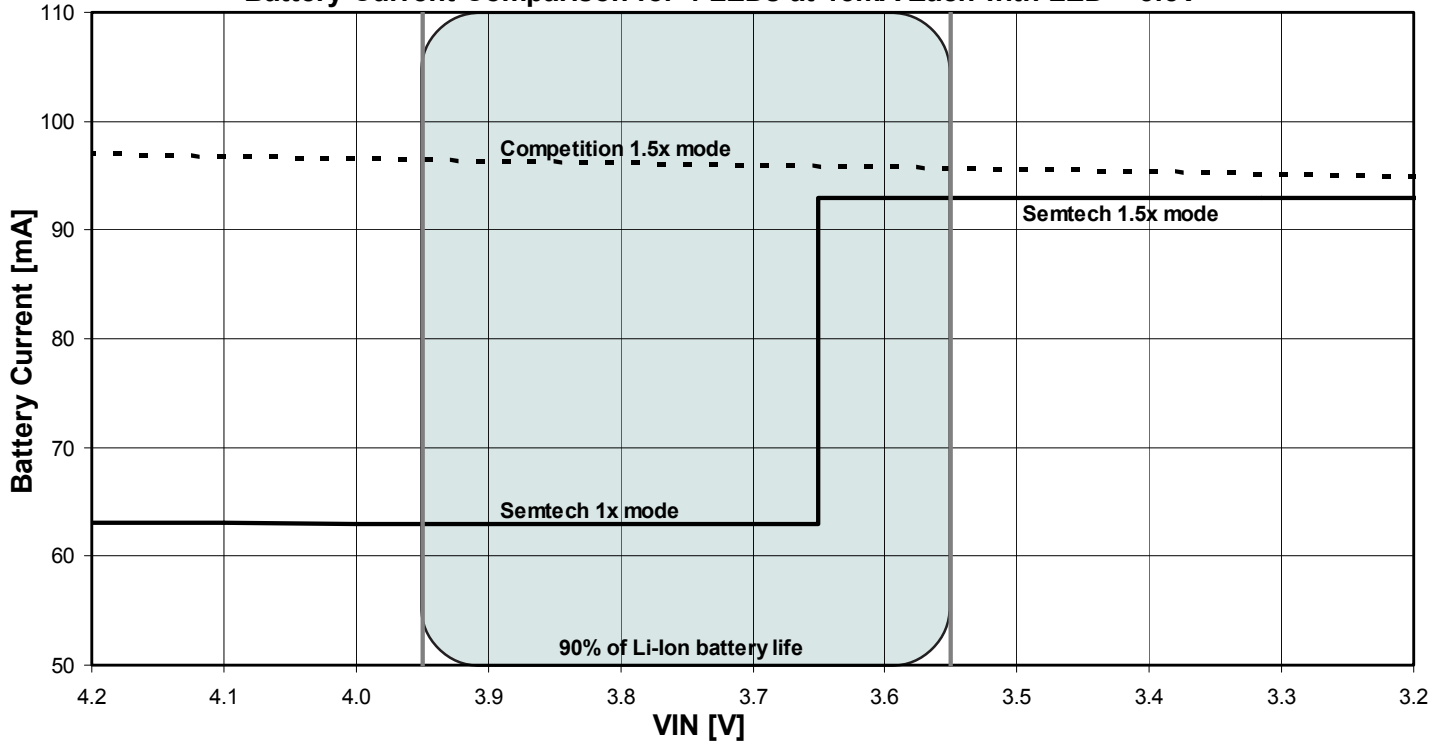

Efficiency Comparison for 4 LEDs with 15mA Each and LED = 3.5V

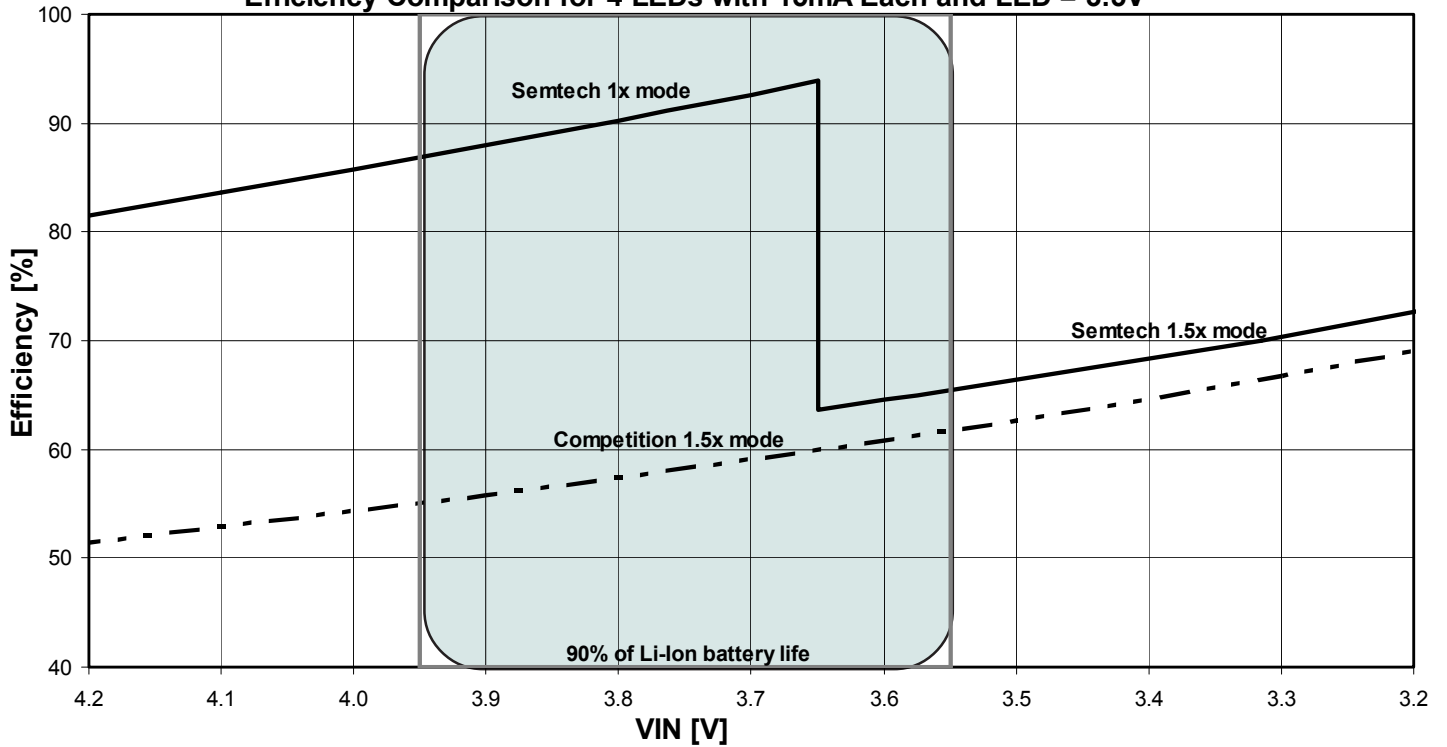

POWER MANAGEMENT

Methods for Setting LED Current

There are four methods for setting and adjusting the LED current outlined here. The methods are:

- 1) R_{SET} only
- 2) Analog Reference V_{ADJ}
- 3) NMOS switched parallel resistors
- 4) PWM Input

Method 1. The most basic means of setting the LED current is with a resistor connected from ISET to GND, as shown in the application circuit on Page 1. The resistor R_{SET} establishes the reference current needed for a constant LED current. Values of R_{SET} for a fixed LED current are given in Table 2 and also in the below graph, "Typical R_{SET} Resistance vs. LED Current". Methods 2 and 3 on page 10 are for setting the LED current allow for brightness control.

Table 2 - Resistor Value Selection

R_{SET} Value			
I _{LED} [mA]	R_{SET} [kΩ]	Nearest kΩ Standard Value	Standard Value % Difference
0.5	931	931	0.0%
1	471	470	-0.2%
2	237	237	0.0%
3	155	154	-0.6%
5	94.0	93.1	-1.0%
10	47.5	47.5	0.0%
15	31.83	31.6	-0.7%
20	24.0	24.0	0.0%
30	16.5	16.5	0.0%

Typical R_{SET} Resistance vs. LED Current

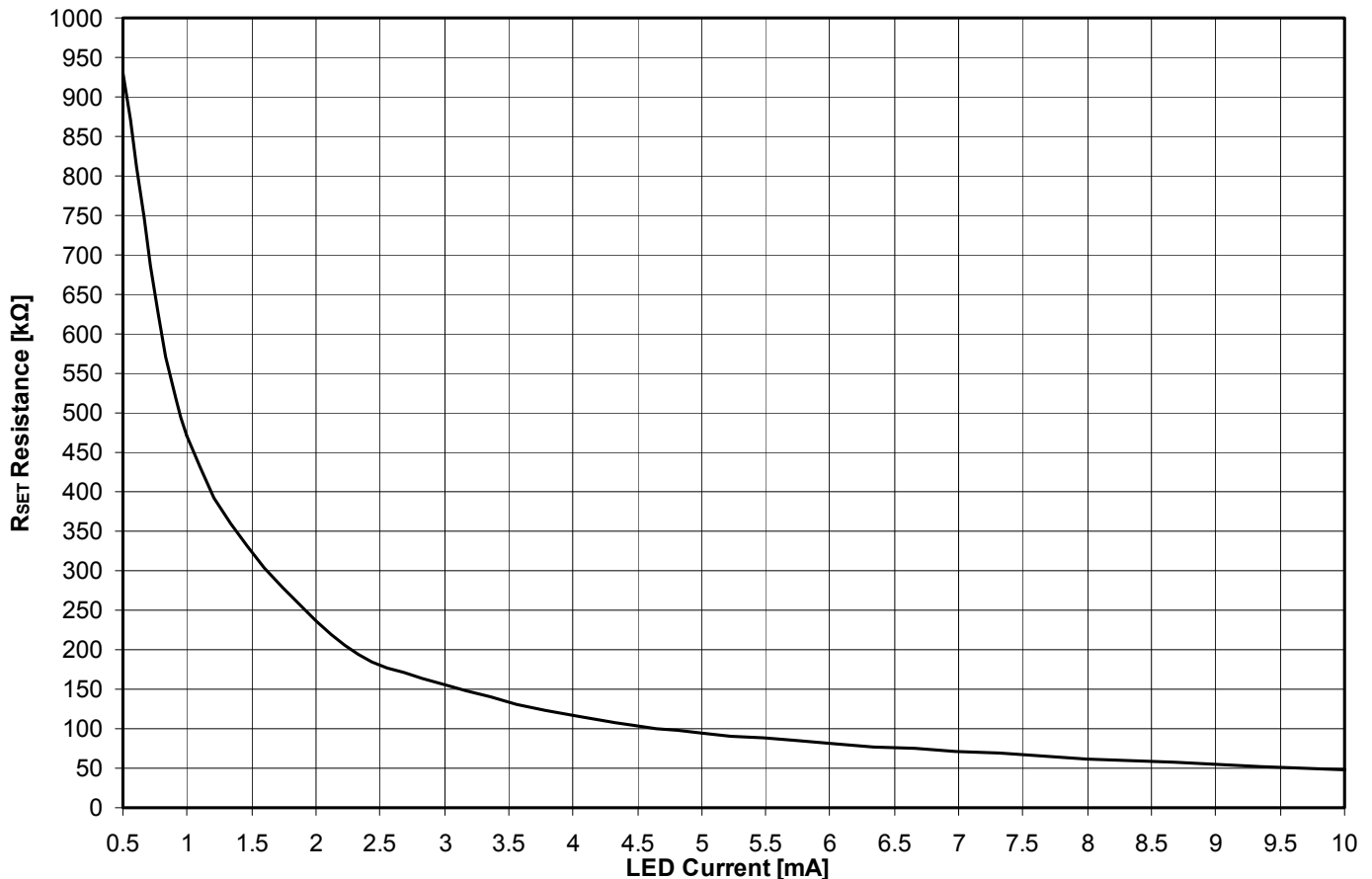

POWER MANAGEMENT

Methods for Setting LED Current (Cont.)

Method 2. The example circuit in Figure 1 uses a 16.5kΩ resistor and an analog input DC voltage, V_{ADJ} , which varies from 1.2V to 0V to control LED current from 1mA to 30mA. Table 3 shows the resulting output. If necessary, the analog V_{ADJ} voltage can be sourced from a voltage higher than 1.2V, but the source must be divided down so that the V_{ADJ} mode will not exceed 1.2V. For lower current applications and for higher resolution, a larger resistor may be substituted in this circuit. PWM applications are also possible with this circuit by application of RC filtering. (Consult with Semtech for detailed application support).

Method 3. The circuit in Figure 2 uses open drain NMOS transistors to set an equivalent resistance for R_{SET} . Parallel combinations are switched on and off for R1, R2 and R3. R4 is always connected, so that a minimum value of LED current can be maintained at 1.5mA.

Figure 1 - Analog Voltage for LED Current Control

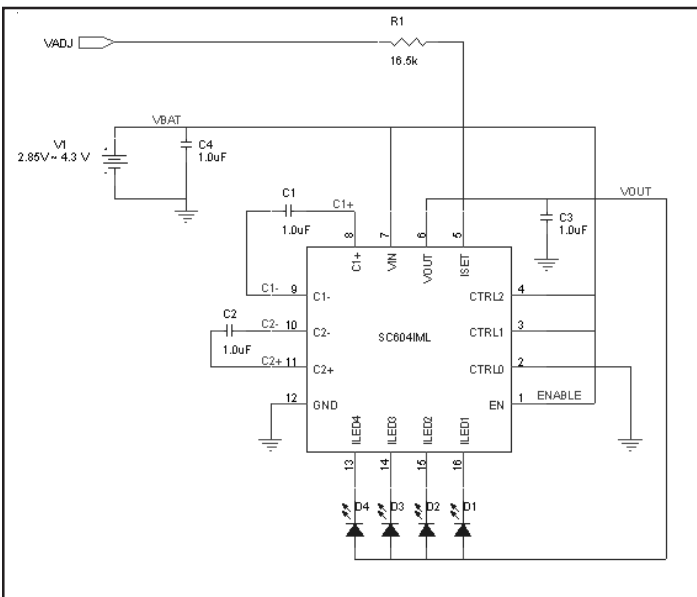

Figure 2 - 3 Bit LED Current Control with Open Drain

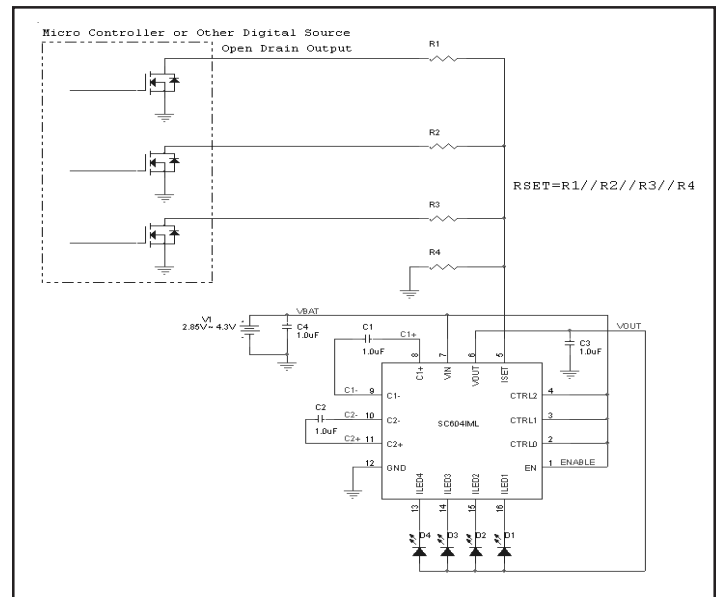

Table 3 - Analog Voltage for LED Current Control

V_{ADJ} [V]	I_{LED} [mA]	V_{ADJ} [V]	I_{LED} [mA]
0.000	30.2	0.600	14.8
0.100	27.7	0.700	12.3
0.200	25.1	0.800	9.7
0.300	22.5	0.900	7.1
0.400	20.0	1.000	2.1
0.500	17.3	1.150	1.0

POWER MANAGEMENT

Methods for Setting LED Current (Cont.)

Method 4. LED current may also be controlled by applying a PWM signal to any of the CTRL2, CTRL1 and CTRL0 inputs. The circuit in Figure 3 turns 4 LEDs on and off by applying a PWM signal to the CTRL0 input. This circuit uses resistor R_{SET} to set the on state current and the average LED current is then proportional to the percentage of on-time when the CTRL0 pin is a logic low. Average LED current is approximately equal to:

$$I_{AVG} = (t_{ON} \cdot I_{LED_ON}) / (t_{ON} + t_{OFF})$$

The recommended PWM frequency is between 100Hz and 500Hz. Due to start up delay and ramp up time, frequency >500Hz will result in error in the average value of I_{LED}. Frequency <100Hz can naturally cause the LEDs to blink visibly.

In PWM applications where ILED4 is not used, keep ILED4 pin 13 open. Connecting ILED4 to ground can result in the charge pump operating in open loop mode. Connecting ILED4 to V_{IN} will work but will cause shutdown current I_Q to increase to approximately V_{IN} / 100k.

Figure 3 - PWM Example Circuit

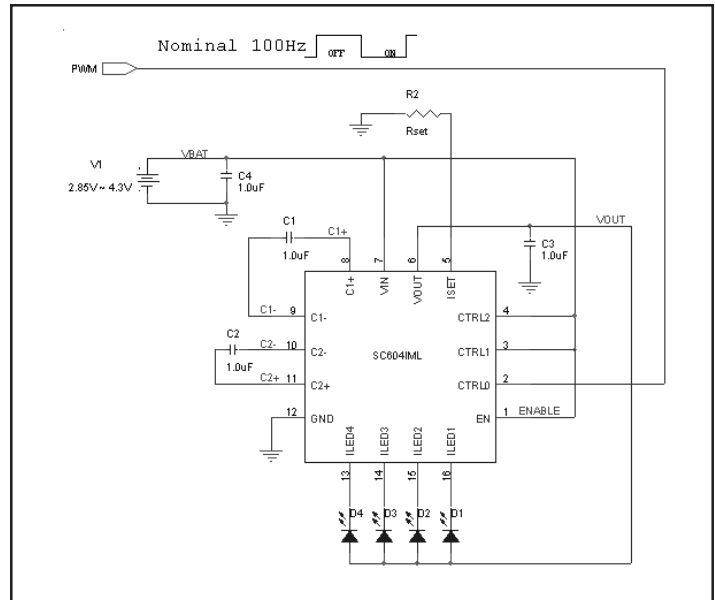

Table 4 - Summary of LED Current Control

LED Current Control Method		Figure of Reference	LED Current Range	Brightness Control
Method 1	R _{SET} Only	Circuit on Page 1	0.5mA < I _{LED} < 30mA	Fixed Brightness
Method 2	Analog Reference V _{ADJ}	Figure 1 on Page 10	0.5mA < I _{LED} < 30mA	Infinite
Method 3	NMOS Switched Parallel Resistors	Figure 2 on Page 10	0.5mA < I _{LED} < 30mA	2 ^N Stepped Current Levels ⁽¹⁾
Method 4	PWM CTRLx Input(s)	Figure 3 on page 11	0.5mA < I _{LED} < 30mA	Infinite

Note: 1) "N" is the number of NMOS transistors used for brightness control.

POWER MANAGEMENT

Typical Characteristics

Startup with 4 LEDs at 20 mA

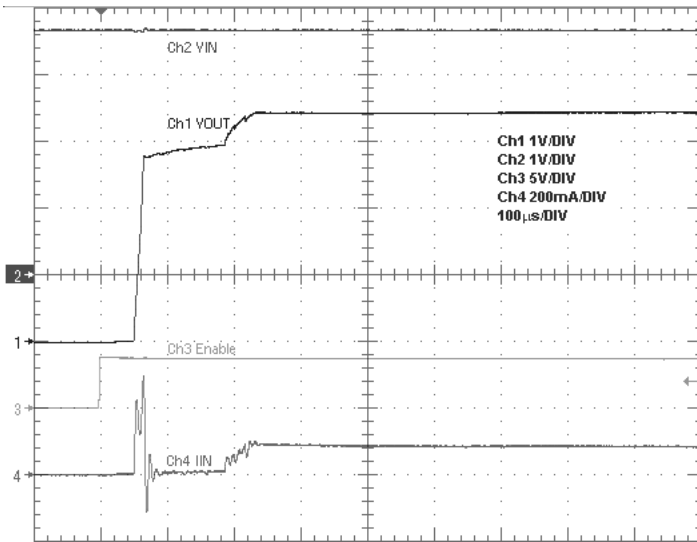

OVP Event with LED Open Circuit

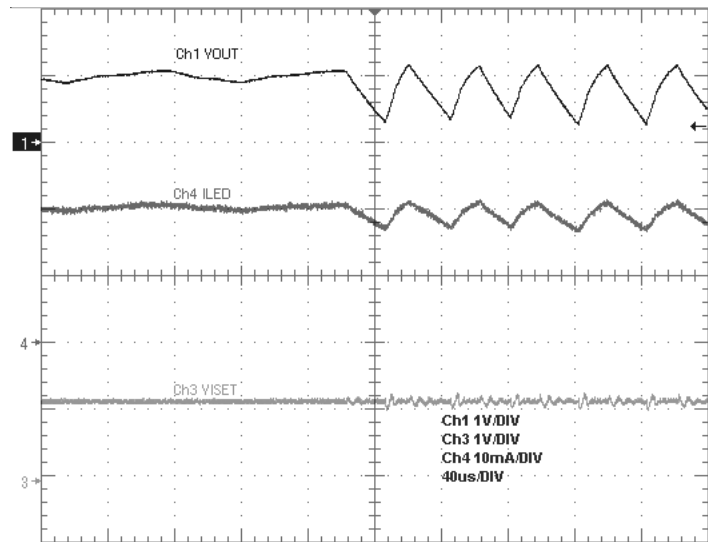

Efficiency vs. Load at High Battery

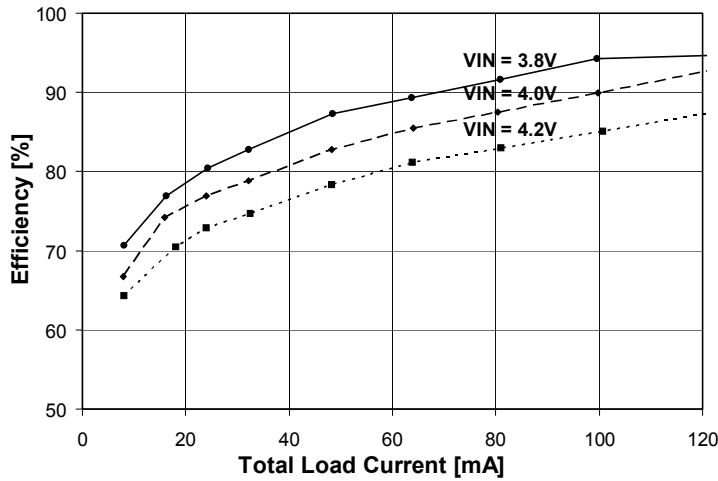

Efficiency vs. Load at Low Battery

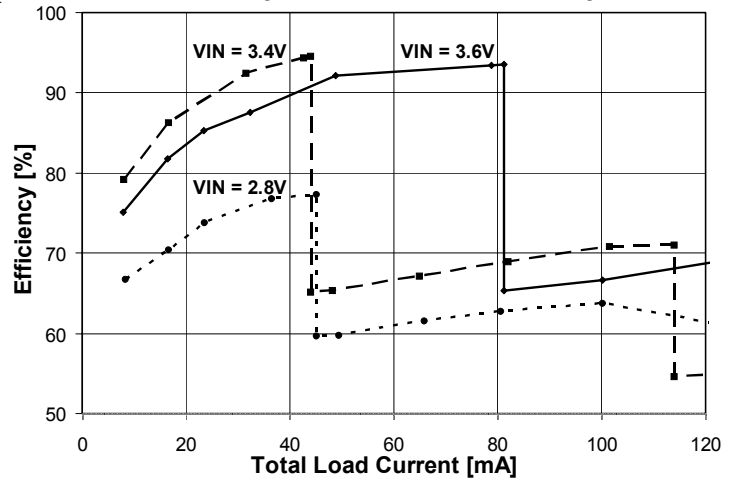

Mode Transition Voltage vs. LED Voltage

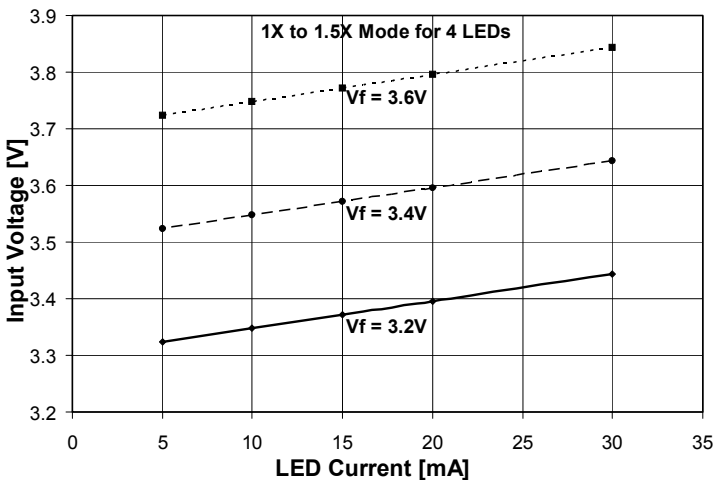

Quiescent Current Trend

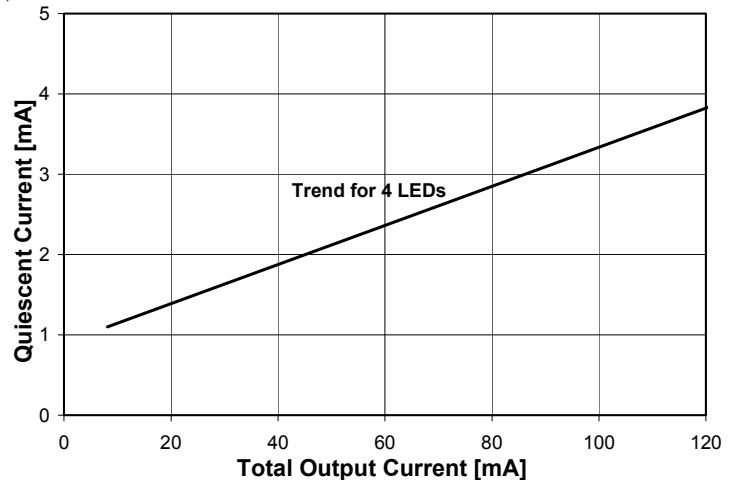

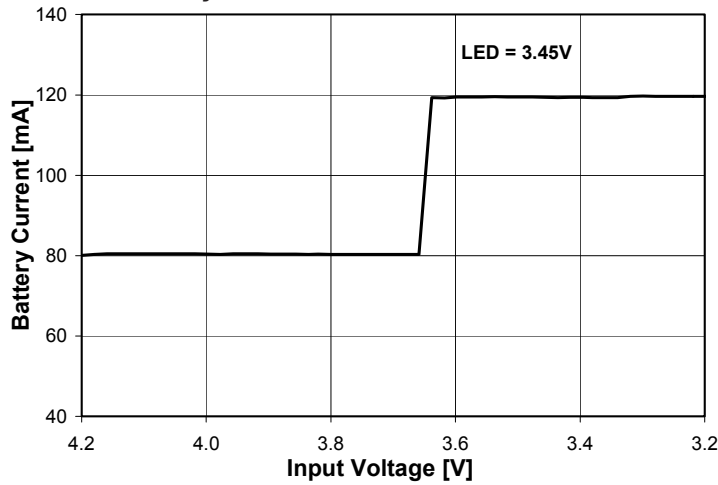
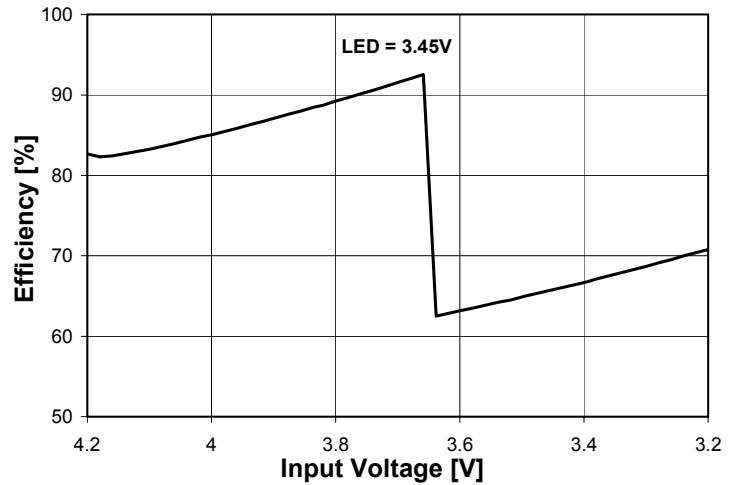
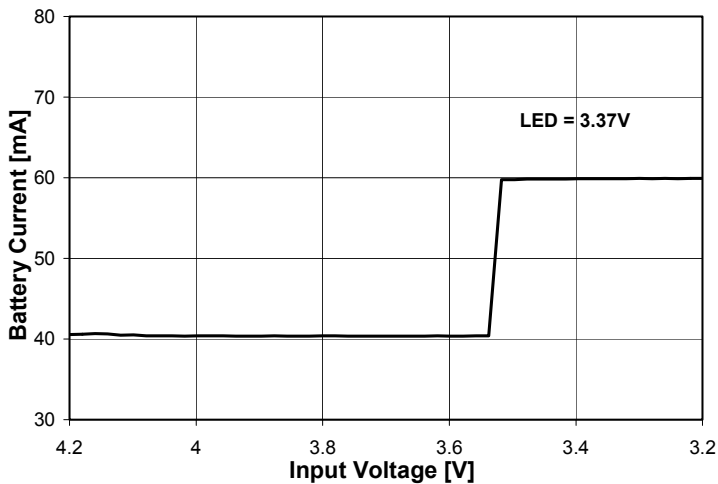
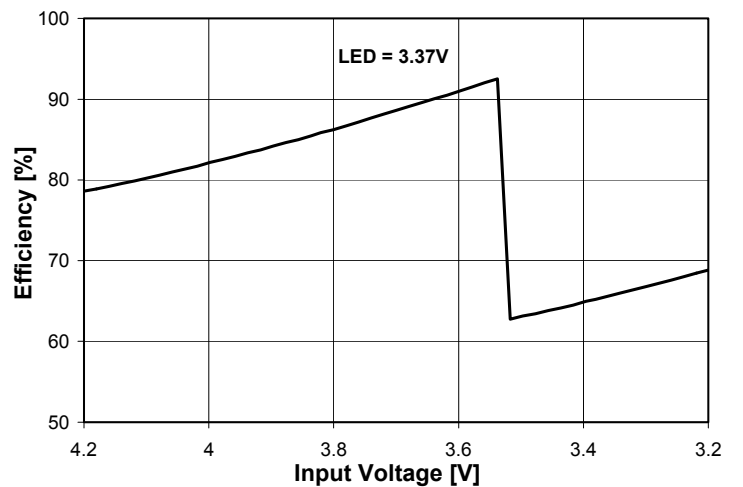
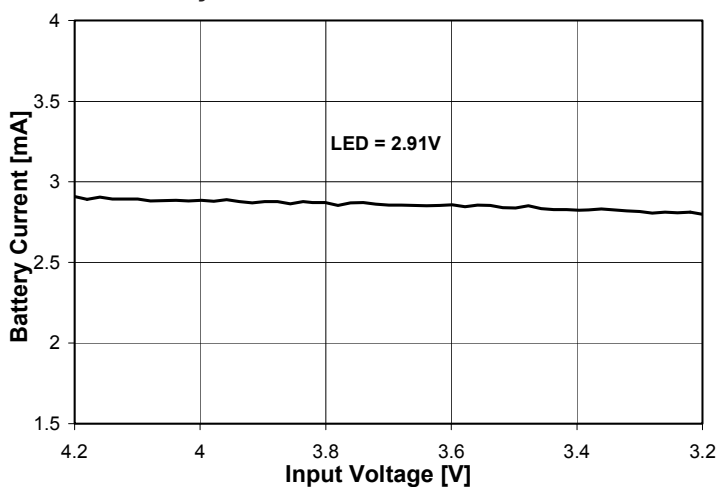
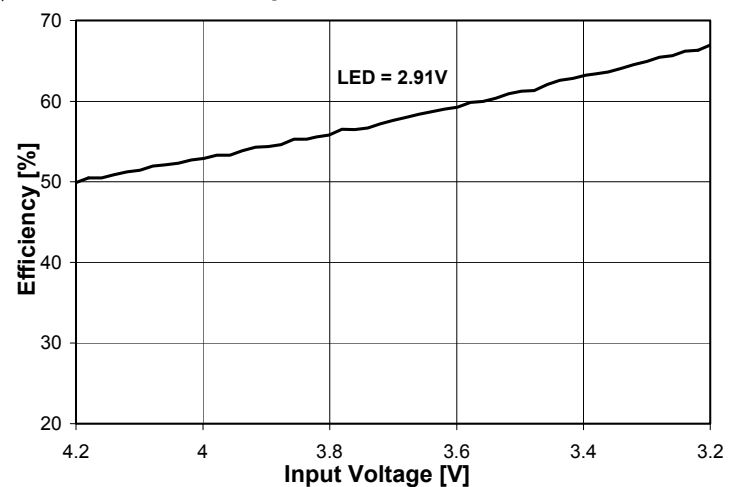
POWER MANAGEMENT
Typical Characteristics with 4 LEDs
Battery Current for 4 LEDs at 20mA

Efficiency for 4 LEDs at 20mA

Battery Current for 4 LEDs at 10mA

Efficiency for 4 LEDs at 10mA

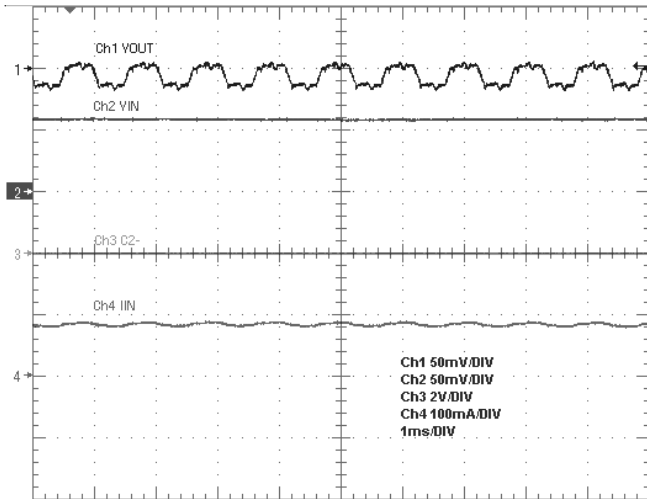
Battery Current for 4 LEDs at 0.5mA

Efficiency for 4 LEDs at 0.5mA

POWER MANAGEMENT

Typical Characteristics with 4 LEDs

Ripple in 1x Mode for 4 LEDs at 20mA Each



Ripple in 1.5x Mode for 4 LEDs at 20mA Each

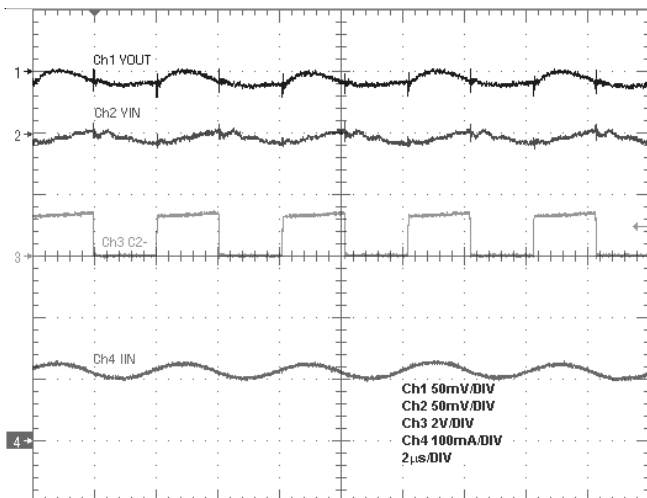

Ripple in 2x Mode for 4 LEDs at 20mA Each

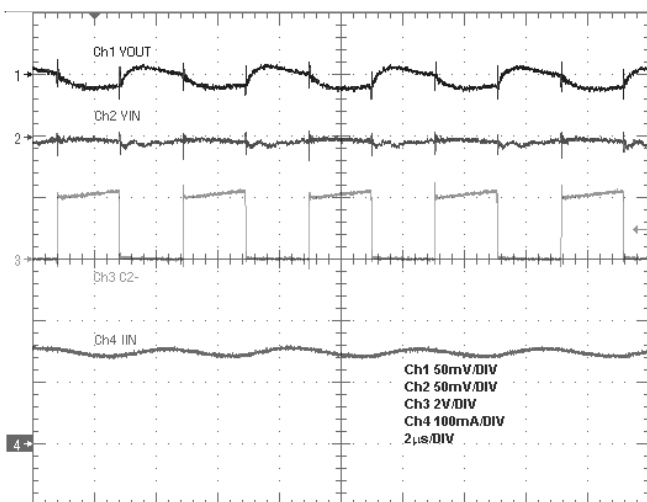

POWER MANAGEMENT

Evaluation Board Schematic

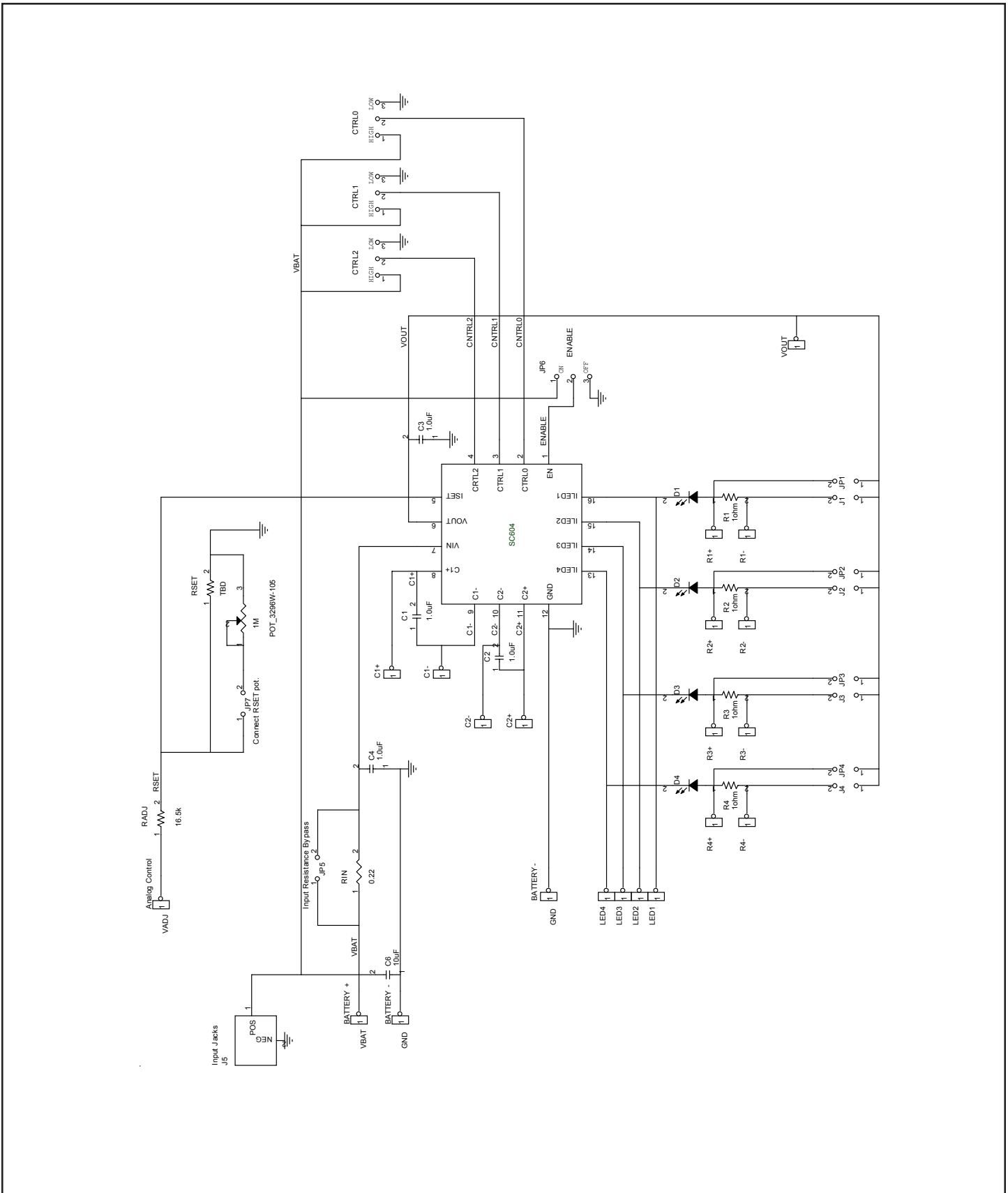

POWER MANAGEMENT

Evaluation Board Bill of Materials

Reference	Value	Comment
U1	SC604A	Component references in bold are the only essential design components.
C1,C2,C3,C4	1.0 μ F	Bucket, input and output capacitors. Ceramic, low ESR type, 6.3V rating or higher.
C6	10 μ F	This extra capacitor supports usage of long power leads from benchtop supply.
D1,D2,D3,D4	-	Add LEDs to meet the requirements of the application.
J1, J2, J3, J4	-	Jumpers in series with each LED.
JP1,JP2,JP3,JP4	-	Jumpers to bypass each 1 Ω sense resistor and bypass J1, J2, J3 and J4.
JP5	-	Jumper for bypassing the R4 input resistor.
JP6	-	Enable jumper.
JP7	-	Connects RSET potentiometer. Remove this jumper when using a fixed value R1.
CTRL0,CTRL1,CTRL2	-	Jumpers provide High/Low settings for the control bits.
RSET	-	RSET resistor
	3296W-105	Evaluation board has 1M Ω potentiometer in place of R1.
R4	0.22 Ω	Series input resistor for studying effects of input resistance.
RADJ	16.5k Ω	Resistor for analog brightness control. Apply test signal of 0 to 1.2V at VADJ test point.
J5	-	Banana jacks for power supply.

Evaluation Board Gerber Plots

Top View

Bottom View

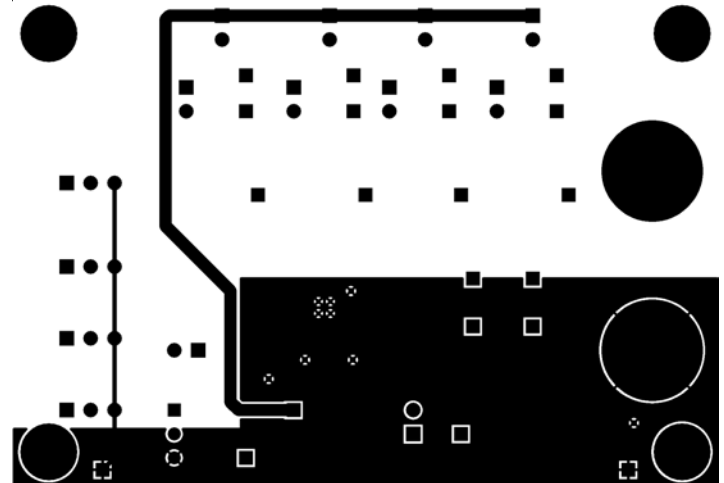
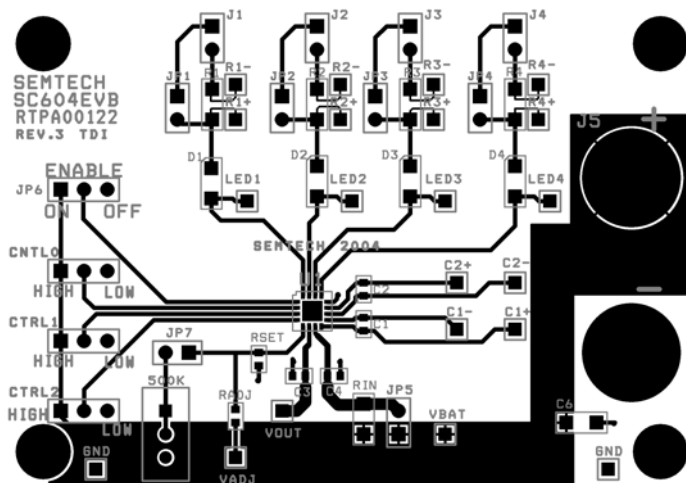

POWER MANAGEMENT

Outline Drawing- MLP-16 [4x4]

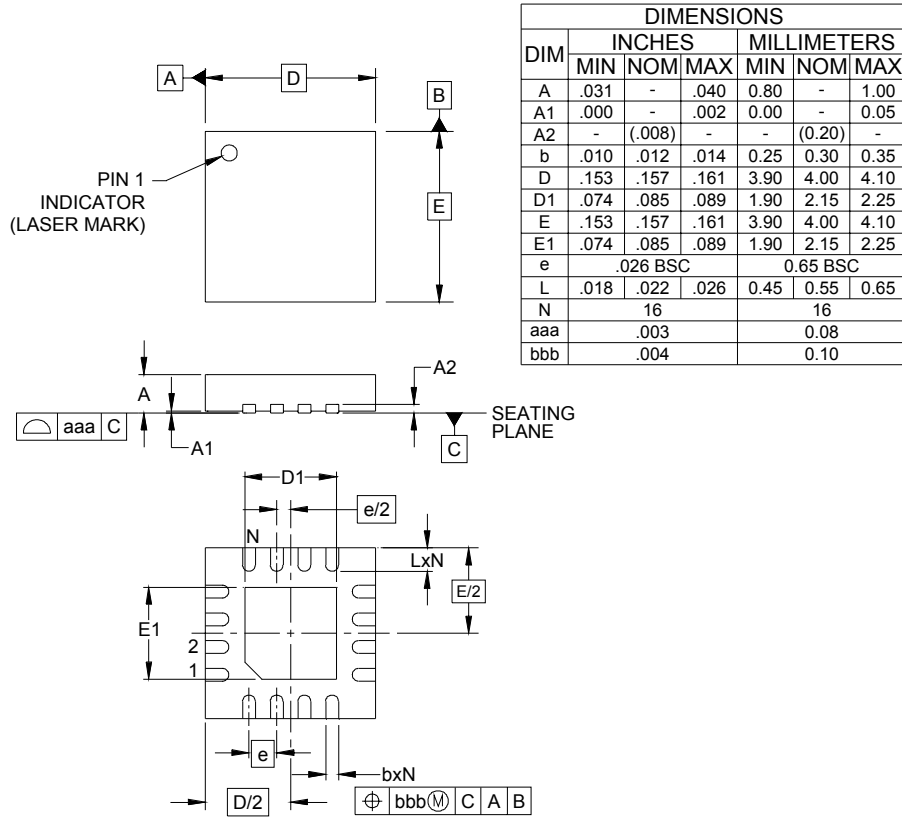

- NOTES:
1. CONTROLLING DIMENSIONS ARE IN MILLIMETERS (ANGLES IN DEGREES).
 2. COPLANARITY APPLIES TO THE EXPOSED PAD AS WELL AS THE TERMINALS.

Marking Information

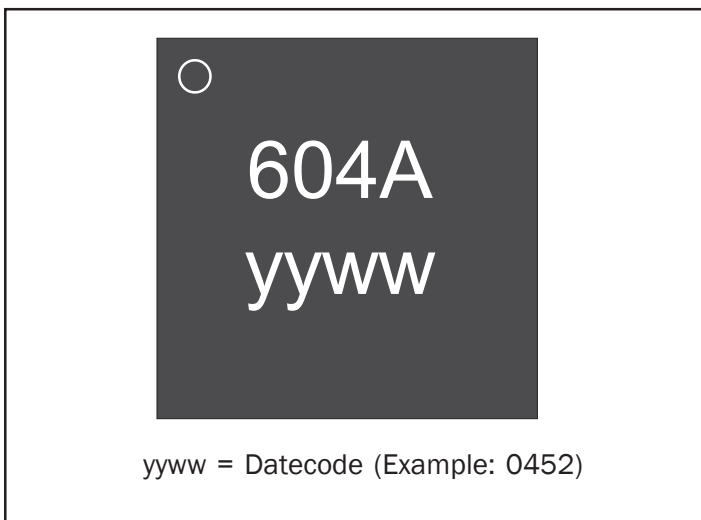

POWER MANAGEMENT

Land Pattern MLP-16pin [4x4]

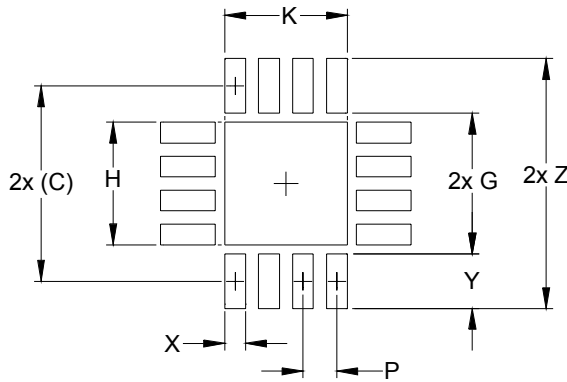

DIMENSIONS		
DIM	INCHES	MILLIMETERS
C	(.148)	(3.75)
G	.106	2.70
H	.091	2.30
K	.091	2.30
P	.026	0.65
X	.016	0.40
Y	.041	1.05
Z	.189	4.80

NOTES:

1. THIS LAND PATTERN IS FOR REFERENCE PURPOSES ONLY. CONSULT YOUR MANUFACTURING GROUP TO ENSURE YOUR COMPANY'S MANUFACTURING GUIDELINES ARE MET.

Contact Information

Semtech Corporation
 Power Management Products Division
 200 Flynn Road, Camarillo, CA 93012
 Phone: (805) 498-2111 FAX (805) 498-3804

Visit us at: www.semtech.com