



# QEV101

SMD 7x5 VCXO – Communications Equipment Application  
*Specification (Rev-F)*

---

▣ Electrical Characteristics .....	P01
▣ Mechanical Characteristics .....	P02
▣ Ordering Information .....	P03
▣ Suggested Reflow Soldering profile .....	P03
▣ Tape Drawing.....	P04
▣ Reel Drawing .....	P04

# QEV101

## SMD 7x5 VCXO – Communications Equipment Application Specification (rev-F)

April 05<sup>th</sup>, 2006

### Electrical Characteristics

Electrical Parameters	Unit	Minimum	Typical	Maximum	Test conditions
Frequency range	MHz	1.544		65.536	
Output logic	HCMOS / TTL Output				
Operating temperature range (see table 1)	°C		0 to +70	-40 to +85	Refer to Ordering Information
Storage temperature range	°C	-55		+125	
Power supply voltage (V <sub>CC</sub> ) 3.3V version 5.0V version	V <sub>DC</sub>	3.135 4.750	3.3 5.0	3.465 5.250	Refer to Ordering Information
Frequency Stability (see note 1)	± ppm	±25 or ±50			Refer to Ordering Information
Aging (First Year)	± ppm			3	Ref at 25°C
Input current 3.3V version 5.0V version	mA			40mA 55mA	
HCMOS Output load	pF		15	30	
Output Logic Levels Output Logic High (V <sub>OH</sub> ) Output Logic Low (V <sub>OL</sub> )	V <sub>DC</sub>	90%V <sub>CC</sub>		10%V <sub>CC</sub>	With 30pF HCMOS Load
Pullability 3.3V ⇒ V <sub>C</sub> =1.65 ±1.50V 5.0V ⇒ V <sub>C</sub> =2.50 ±2.00V	± ppm	±50, ±100 or ±150 Positive slope			Refer to Ordering Information
Linearity	%			20	
Duty cycle	%	45	50	55	
Rise & Fall time	ns			10	20% V <sub>CC</sub> ~ 80% V <sub>CC</sub>
Start-up time	ms			10	
Input Impedance	KΩ	100			

**Note 1:** Include 25°C tolerance, operating temperature range, input voltage change (V<sub>CC</sub>±5%), load change (15pF±10%), first year aging, shock and vibration.

	± 25ppm	± 50ppm
0 to +70°C	C	A
- 40 to +85°C	D	B

Unit	Maximum values for 20MHz VCXO dBc/Hz
10Hz	- 60
100Hz	- 90
1KHz	-120
10KHz	-135
Floor	-145

# QEV101

SMD 7x5 VCXO – Communications Equipment Application  
Specification (rev-F)

April 05<sup>th</sup>, 2006

## ▣ Mechanical Characteristics

### BOTTOM VIEW

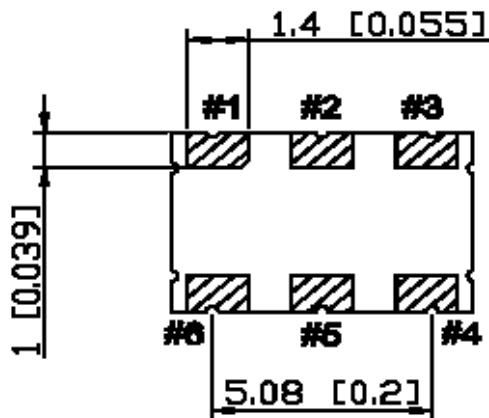

### SUGGESTED PAD

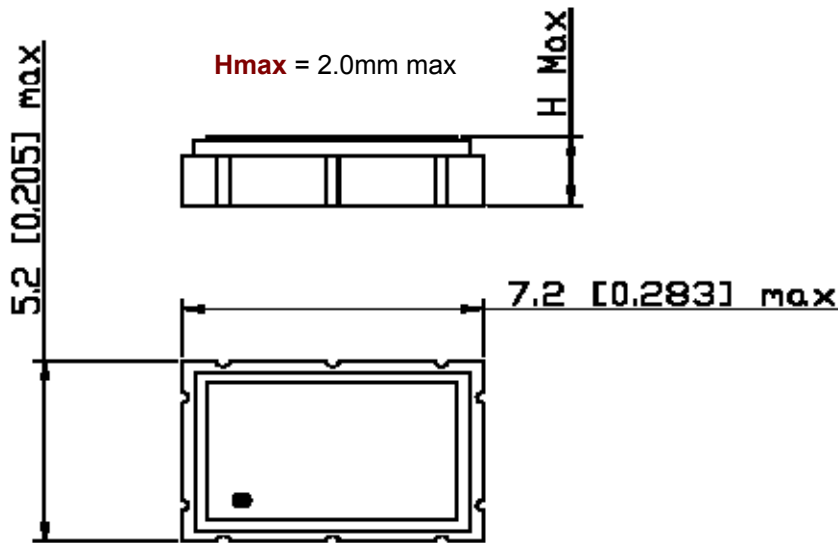
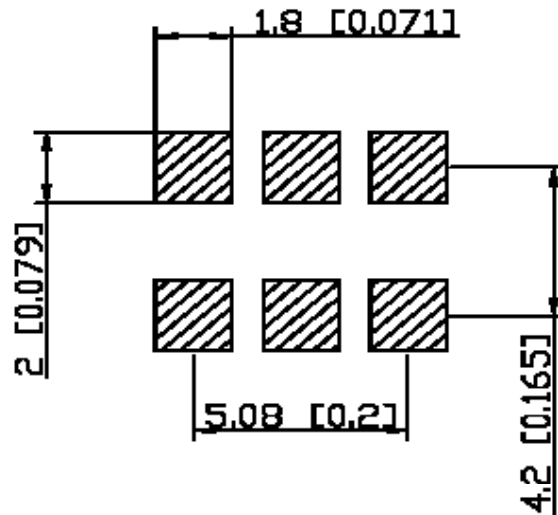

Pin connections	
#1	V <sub>CONTROL</sub>
#2	Tri state
#3	Ground
#4	Output
#5	N.C.
#6	+V <sub>CC</sub>

Marking	
Line 1	Manufacturing code + V1 + stability/supply voltage/pulling code
Line 2	Frequency in MHz (6 digits)
Line 3	Date code (YYWW)

Example for QEV101BAB / 10MHz

- ⇨ Line 1 : NV1BAB
- ⇨ Line 2 : 10.000
- ⇨ Line 3 : 0614

Tristate Function	
Pin ≠1	Output (Pin ≠4)
Open	Active
"1"	Active
"0"	High Z

# QEV101

SMD 7x5 VCXO – Communications Equipment Application  
 Specification (rev-F)

April 05<sup>th</sup>, 2006

## Ordering Information

Part numbering system				
QEV101	B	A	B	10.000MHZ
Package type	Temperature Stability	Supply Voltage	Pulling Range	Nominal Frequency (MHz)
<b>SMD Package</b> QEV101 : SMD 7x5	A : ± 50ppm vs 0 to +70°C B : ± 50ppm vs -40 to +85°C C : ± 25ppm vs 0 to +70°C D : ± 50ppm vs -40 to +85°C	A : + 5.0V D : +3.3V	A : ± 100ppm min B : ± 150ppm min D : ± 50ppm min	Please enter the nominal frequency

## Suggested Reflow Soldering Profile

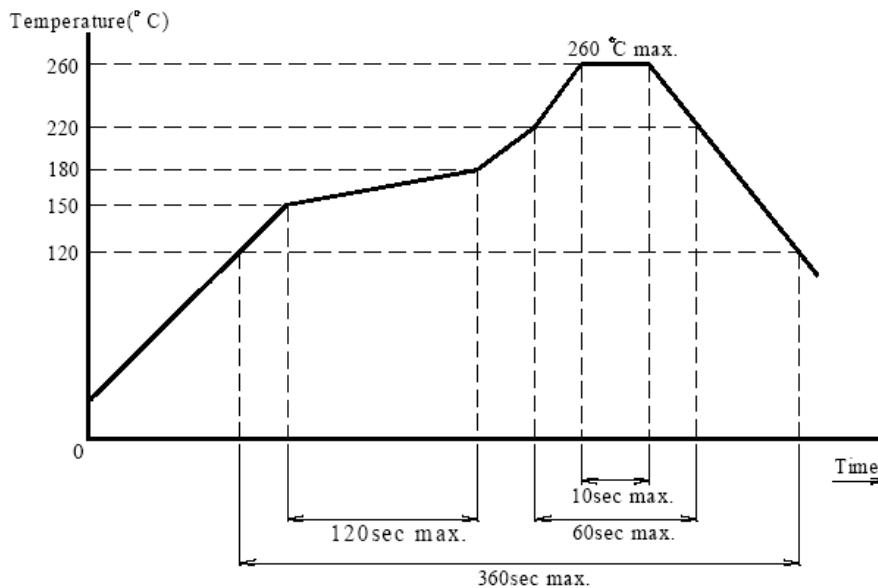

# QEV101

SMD 7x5 VCXO – Communications Equipment Application  
Specification (rev-F)

April 05<sup>th</sup>, 2006

## ▣ Tape Drawing

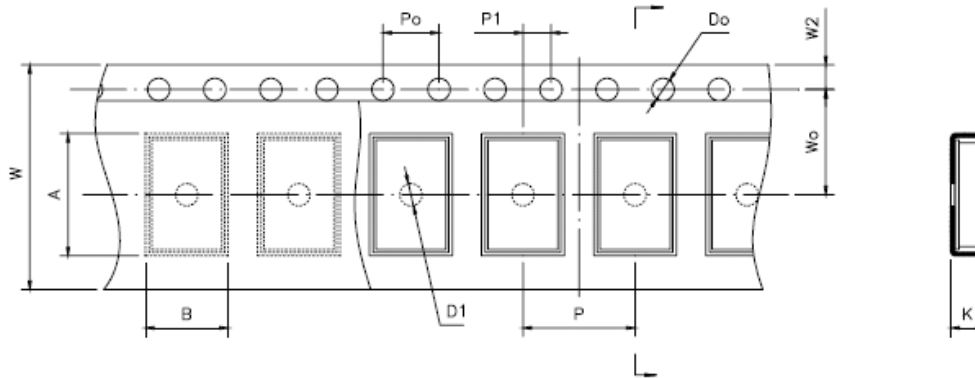

Item	Code	Dimension	Tolerance
Pitch of components	P	8.0	± 0.1
Pitch of sprocket hole	Po	4.0	± 0.1
Length from hole center to component center	P1	2.0	± 0.1
Width of carrier tape	W	16.0	+0.3/-0.1
Width of adhesive tape	W0	7.5	± 0.1
Height of component hole	A	8.18	± 0.1
Width of component hole	B	5.56	± 0.1
Gap of hold down tape and carrier tape	W2	1.75	± 0.1
Diameter of sprocket hole	Do	∅ 1.5	± 0.05
Diameter of feed hole	D1	∅ 1.5	± 0.25
Total of tape thickness	K	2.16	± 0.1

## ▣ Reel Drawing

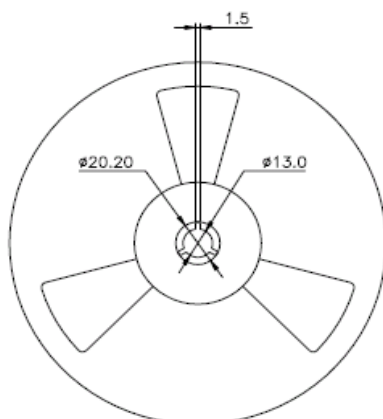

Multiple : 1Kpcs per Reel

Unit : mm

