

TLV1112 1.2-V, 0.8-A LOW-DROPOUT VOLTAGE REGULATOR

SLVS562B – DECEMBER 2004 – REVISED APRIL 2005

- Output Current of Up to 800 mA
- Operates Down to 1.1-V Dropout
- Specified Dropout Voltage at Multiple Current Levels
- 0.2% Line Regulation Maximum
- 0.5% Load Regulation Maximum

KCS (TO-220) PACKAGE
(TOP VIEW)

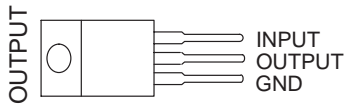

KTP (PowerFLEX™) PACKAGE
(TOP VIEW)

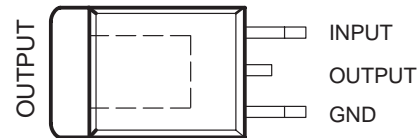

KTT (TO-263) PACKAGE
(TOP VIEW)

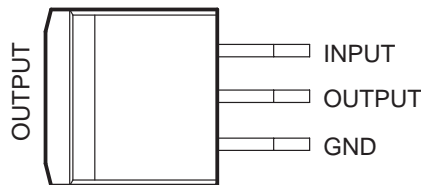

DCY (SOT-223) PACKAGE
(TOP VIEW)

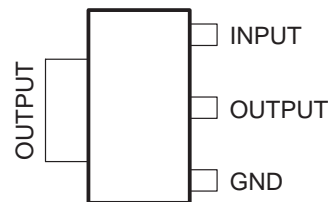

description/ordering information

The TLV1112 is a low-dropout voltage regulator, designed to provide up to 800 mA of output current at 1.2 V (typ). All internal circuitry is designed to operate down to 1.1-V input-to-output differential. Dropout voltage is specified at a maximum of 1.3 V at 800 mA, decreasing at lower load currents.

ORDERING INFORMATION

T _J	V _O TYP (V)	PACKAGE†		ORDERABLE PART NUMBER	TOP-SIDE MARKING
-40°C to 125°C	1.2 V	PowerFLEX™ (KTP)	Reel of 2000	TLV1112IKTPR	
		SOT-223 (DCY)	Tube of 80	TLV1112IDCY	
			Reel of 2500	TLV1112IDCYR	
		TO-220 (KCS)	Tube of 50	TLV1112IKCS	
		TO-263 (KTT)	Tube of 50	TLV1112IKTT	
Reel of 1000	TLV1112IKTTR				
0°C to 125°C	1.2 V	PowerFLEX (KTP)	Reel of 2000	TLV1112CKTPR	
		SOT-223 (DCY)	Tube of 80	TLV1112CDCY	
			Reel of 2500	TLV1112CDCYR	
		TO-220 (KCS)	Tube of 50	TLV1112CKCS	
		TO-263 (KTT)	Tube of 50	TLV1112CKTT	
Reel of 1000	TLV1112CKTTR				

† Package drawings, standard packing quantities, thermal data, symbolization, and PCB design guidelines are available at www.ti.com/sc/package.



Please be aware that an important notice concerning availability, standard warranty, and use in critical applications of Texas Instruments semiconductor products and disclaimers thereto appears at the end of this data sheet.

PowerFLEX is a trademark of Texas Instruments.

PRODUCT PREVIEW information concerns products in the formative or design phase of development. Characteristic data and other specifications are design goals. Texas Instruments reserves the right to change or discontinue these products without notice.



POST OFFICE BOX 655303 • DALLAS, TEXAS 75265

Copyright © 2005, Texas Instruments Incorporated

PRODUCT PREVIEW

TLV1112

1.2-V, 0.8-A LOW-DROPOUT VOLTAGE REGULATOR

SLVS562B – DECEMBER 2004 – REVISED APRIL 2005

description/ordering information (continued)

The low-profile surface-mount KTP package allows the device to be used in applications where space is limited. The TLV1112 requires a minimum of 10 μ F of output capacitance for stability. Output capacitors of this size or larger normally are included in most regulator designs.

Unlike pnp-type regulators, where up to 10% of the output current is wasted as quiescent current, the quiescent current of the TLV1112 flows into the load, increasing efficiency.

The TLV1112C is characterized for operation over the virtual junction temperature range of 0°C to 125°C. The TLV1112I is characterized for operation over the virtual junction temperature range of –40°C to 125°C.

absolute maximum ratings over operating free-air temperature range (unless otherwise noted)†

Continuous input voltage	20 V
Operating virtual junction temperature, T_J	150°C
Storage temperature range, T_{stg}	–65°C to 150°C

† Stresses beyond those listed under “absolute maximum ratings” may cause permanent damage to the device. These are stress ratings only, and functional operation of the device at these or any other conditions beyond those indicated under “recommended operating conditions” is not implied. Exposure to absolute-maximum-rated conditions for extended periods may affect device reliability.

package thermal data (see Note 1)

PACKAGE	BOARD	$\theta_{JP}\ddagger$	θ_{JC}	θ_{JA}
PowerFLEX™ /TO-252 (KTP)	High K, JESD 51-5	1.4°C/W	19°C/W	28°C/W
SOT (DCY)	High K, JESD 51-7		4°C/W	53°C/W
TO-220 (KCS)	High K, JESD 51-5	3°C/W	17°C/W	19°C/W
TO-263 (KTT)	High K, JESD 51-5	TBD		TBD

NOTE 1: Maximum power dissipation is a function of $T_{J(max)}$, θ_{JA} , and T_A . The maximum allowable power dissipation at any allowable ambient temperature is $P_D = (T_{J(max)} - T_A)/\theta_{JA}$. Operating at the absolute maximum T_J of 150°C can affect reliability.

‡ For packages with exposed thermal pads, such as QFN, PowerPAD, or PowerFLEX, θ_{JP} is defined as the thermal resistance between the die junction and the bottom of the exposed pad.

recommended operating conditions

		MIN	MAX	UNIT	
V_{IN}	Input voltage	2.7	15	V	
I_{OUT}	Output current		800	mA	
T_J	Operating virtual junction temperature range	TLV1112I	–40	125	°C
		TLV1112C	0	125	

PRODUCT PREVIEW



TLV1112

1.2-V, 0.8-A LOW-DROPOUT VOLTAGE REGULATOR

SLVS562B – DECEMBER 2004 – REVISED APRIL 2005

**electrical characteristics, $T_J = 0^\circ\text{C}$ to 125°C , all typical values are at $T_J = 25^\circ\text{C}$
(unless otherwise noted)**

PARAMETER	TEST CONDITIONS†	TLV1112C			UNIT
		MIN	TYP	MAX	
Output voltage, V_{OUT}	$V_{IN} - V_{OUT} = 2\text{ V}$, $I_{OUT} = 10\text{ mA}$, $T_J = 25^\circ\text{C}$	1.17	1.2	1.23	V
	$10\text{ mA} \leq I_{OUT} \leq 800\text{ mA}$, $1.4\text{ V} \leq V_{IN} - V_{OUT} \leq 10\text{ V}$	1.14	1.2	1.26	
Line regulation	$I_{OUT} = 10\text{ mA}$, $1.5 \leq V_{IN} - V_{OUT} \leq 13.8\text{ V}$		0.035	0.2	%
Load regulation	$10\text{ mA} \leq I_{OUT} \leq 800\text{ mA}$, $V_{IN} - V_{OUT} = 3\text{ V}$		0.1	0.5	%
Dropout voltage (see Note 4)	$I_{OUT} = 100\text{ mA}$		1.1	1.2	V
	$I_{OUT} = 500\text{ mA}$		1.15	1.25	
	$I_{OUT} = 800\text{ mA}$		1.2	1.3	
Current limit	$V_{IN} - V_{OUT} = 5\text{ V}^\ddagger$, $T_J = 25^\circ\text{C}$	0.8	1.2	1.5	A
Quiescent current	$V_{IN} \leq 15\text{ V}$		5	10	mA
Thermal regulation	30 ms pulse, $T_A = 25^\circ\text{C}$		0.01	0.1	%/W
Ripple rejection	$V_{IN} - V_{OUT} = 3\text{ V}$, $V_{ripple} = 1\text{ V}_{pp}$, $f = 120\text{ Hz}$	60	75		dB
Minimum load current	$V_{IN} = 15\text{ V}$		1.7	5	mA
Temperature stability	$T_J = 0^\circ\text{C}$ to 125°C		0.5		%
Long-term stability	1000 hrs, No load, $T_A = 125^\circ\text{C}$		0.3		%
Output noise voltage (% of V_{OUT})	$f = 10\text{ Hz}$ to 100 kHz		0.003		%

† All characteristics are measured with a 10- μF capacitor across the input and a 10- μF capacitor across the output. Pulse testing techniques are used to maintain the junction temperature as close to the ambient temperature as possible.

‡ Current limit test specified under recommended operating conditions

NOTE 2: Dropout is defined as the input-to-output differential at which V_{OUT} drops 100 mV below the value of V_{OUT} , measured at $V_{IN} = V_{OUT(nom)} + 1.5\text{ V}$.

**electrical characteristics, $T_J = -40^\circ\text{C}$ to 125°C , all typical values are at $T_J = 25^\circ\text{C}$
(unless otherwise noted)**

PARAMETER	TEST CONDITIONS†	TLV1112I			UNIT
		MIN	TYP	MAX	
Output voltage, V_{OUT}	$V_{IN} - V_{OUT} = 2\text{ V}$, $I_{OUT} = 10\text{ mA}$, $T_J = 25^\circ\text{C}$	1.17	1.2	1.23	V
	$10\text{ mA} \leq I_{OUT} \leq 800\text{ mA}$, $1.4\text{ V} \leq V_{IN} - V_{OUT} \leq 10\text{ V}$	1.14	1.2	1.26	
Line regulation	$I_{OUT} = 10\text{ mA}$, $1.5 \leq V_{IN} - V_{OUT} \leq 13.8\text{ V}$		0.035	0.3	%
Load regulation	$10\text{ mA} \leq I_{OUT} \leq 800\text{ mA}$, $V_{IN} - V_{OUT} = 3\text{ V}$		0.2	0.5	%
Dropout voltage (see Note 4)	$I_{OUT} = 100\text{ mA}$		1.1	1.3	V
	$I_{OUT} = 500\text{ mA}$		1.15	1.35	
	$I_{OUT} = 800\text{ mA}$		1.2	1.4	
Current limit	$V_{IN} - V_{OUT} = 5\text{ V}^\ddagger$, $T_J = 25^\circ\text{C}$	0.8	1.2	1.5	A
Quiescent current	$V_{IN} \leq 15\text{ V}$		5	15	mA
Thermal regulation	30 ms pulse, $T_A = 25^\circ\text{C}$		0.01	0.1	%/W
Ripple rejection	$V_{IN} - V_{OUT} = 3\text{ V}$, $V_{ripple} = 1\text{ V}_{pp}$, $f = 120\text{ Hz}$	60	75		dB
Minimum load current	$V_{IN} = 15\text{ V}$		1.7	5	mA
Temperature stability	$T_J = -40^\circ\text{C}$ to 125°C		0.5		%
Long-term stability	1000 hrs, No load, $T_A = 125^\circ\text{C}$		0.3		%
Output noise voltage (% of V_{OUT})	$f = 10\text{ Hz}$ to 100 kHz		0.003		%

† All characteristics are measured with a 10- μF capacitor across the input and a 10- μF capacitor across the output. Pulse-testing techniques are used to maintain the junction temperature as close to the ambient temperature as possible.

‡ Current limit test specified under recommended operating conditions

NOTE 4: Dropout is defined as the input-to-output differential at which V_{OUT} drops 100 mV below the value of V_{OUT} , measured at $V_{IN} = V_{OUT(nom)} + 1.5\text{ V}$.



TLV1112

1.2-V, 0.8-A LOW-DROPOUT VOLTAGE REGULATOR

SLVS562B – DECEMBER 2004 – REVISED APRIL 2005

TYPICAL CHARACTERISTICS

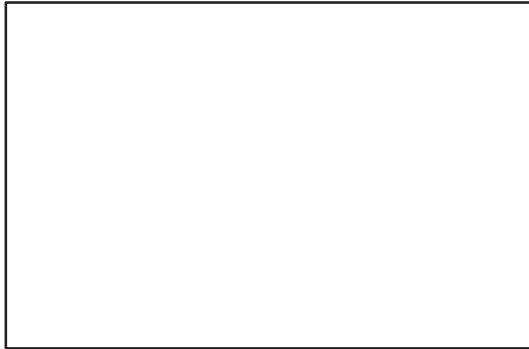

Figure 1. Short-Circuit Current vs ($V_I - V_O$)

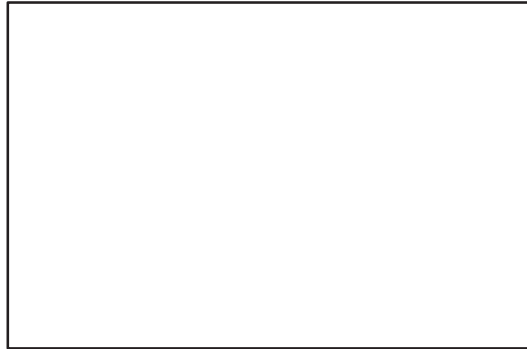

Figure 2. Load Regulation vs Temperature



Figure 3. Ripple Rejection vs Frequency



Figure 4. Ripple Rejection vs Current



Figure 5. Temperature Stability



Figure 6. GND Pin Current vs Temperature

PRODUCT PREVIEW

TYPICAL CHARACTERISTICS



Figure 7. Load-Transient Response



Figure 8. Line-Transient Response

PRODUCT PREVIEW

TLV1112

1.2-V, 0.8-A LOW-DROPOUT VOLTAGE REGULATOR

SLVS562B – DECEMBER 2004 – REVISED APRIL 2005

APPLICATION INFORMATION

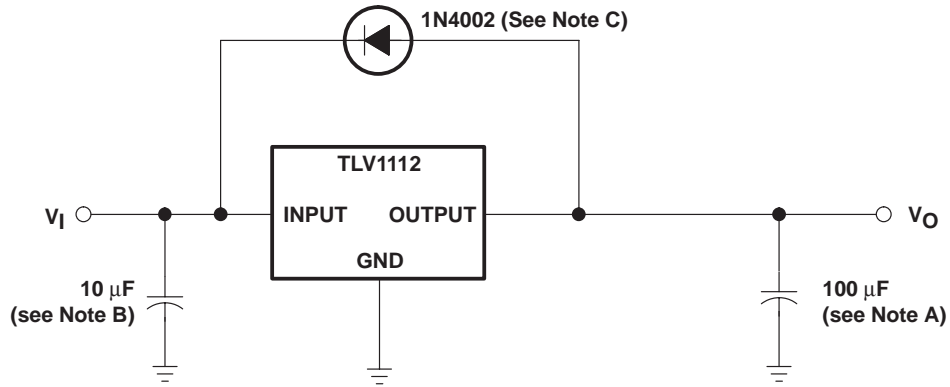

- NOTES: A. Output capacitor selection is critical for regulator stability. The recommended minimum is 10- μF tantalum or 50- μF aluminum electrolytic, with either one having an ESR between the range of 0.3 Ω to 22 Ω . Larger C_{OUT} values benefit the regulator by improving transient response and loop stability.
- B. C_{IN} is recommended if TLV1112 is not located near the power-supply filter.
- C. An external diode is recommended to protect the regulator if the input instantaneously is shorted to GND.

Figure 9. Typical Application Circuit

PRODUCT PREVIEW

PACKAGING INFORMATION

Orderable Device	Status ⁽¹⁾	Package Type	Package Drawing	Pins	Package Qty	Eco Plan ⁽²⁾	Lead/Ball Finish	MSL Peak Temp ⁽³⁾
TLV1112IDCY	PREVIEW	SOT-223	DCY	4	80	TBD	Call TI	Call TI
TLV1112IDCYR	PREVIEW	SOT-223	DCY	4	2500	TBD	Call TI	Call TI
TLV1112IKCS	PREVIEW	TO-220	KCS	3	50	TBD	Call TI	Call TI
TLV1112IKTPR	PREVIEW	PFM	KTP	2	3000	TBD	Call TI	Call TI
TLV1112IKTT	PREVIEW	DDPAK/ TO-263	KTT	3	50	TBD	Call TI	Call TI
TLV1112IKTTR	PREVIEW	DDPAK/ TO-263	KTT	3	500	TBD	Call TI	Call TI

⁽¹⁾ The marketing status values are defined as follows:

ACTIVE: Product device recommended for new designs.

LIFEBUY: TI has announced that the device will be discontinued, and a lifetime-buy period is in effect.

NRND: Not recommended for new designs. Device is in production to support existing customers, but TI does not recommend using this part in a new design.

PREVIEW: Device has been announced but is not in production. Samples may or may not be available.

OBsolete: TI has discontinued the production of the device.

⁽²⁾ Eco Plan - The planned eco-friendly classification: Pb-Free (RoHS), Pb-Free (RoHS Exempt), or Green (RoHS & no Sb/Br) - please check <http://www.ti.com/productcontent> for the latest availability information and additional product content details.

TBD: The Pb-Free/Green conversion plan has not been defined.

Pb-Free (RoHS): TI's terms "Lead-Free" or "Pb-Free" mean semiconductor products that are compatible with the current RoHS requirements for all 6 substances, including the requirement that lead not exceed 0.1% by weight in homogeneous materials. Where designed to be soldered at high temperatures, TI Pb-Free products are suitable for use in specified lead-free processes.

Pb-Free (RoHS Exempt): This component has a RoHS exemption for either 1) lead-based flip-chip solder bumps used between the die and package, or 2) lead-based die adhesive used between the die and leadframe. The component is otherwise considered Pb-Free (RoHS compatible) as defined above.

Green (RoHS & no Sb/Br): TI defines "Green" to mean Pb-Free (RoHS compatible), and free of Bromine (Br) and Antimony (Sb) based flame retardants (Br or Sb do not exceed 0.1% by weight in homogeneous material)

⁽³⁾ MSL, Peak Temp. -- The Moisture Sensitivity Level rating according to the JEDEC industry standard classifications, and peak solder temperature.

Important Information and Disclaimer:The information provided on this page represents TI's knowledge and belief as of the date that it is provided. TI bases its knowledge and belief on information provided by third parties, and makes no representation or warranty as to the accuracy of such information. Efforts are underway to better integrate information from third parties. TI has taken and continues to take reasonable steps to provide representative and accurate information but may not have conducted destructive testing or chemical analysis on incoming materials and chemicals. TI and TI suppliers consider certain information to be proprietary, and thus CAS numbers and other limited information may not be available for release.

In no event shall TI's liability arising out of such information exceed the total purchase price of the TI part(s) at issue in this document sold by TI to Customer on an annual basis.

DCY (R-PDSO-G4)

PLASTIC SMALL-OUTLINE

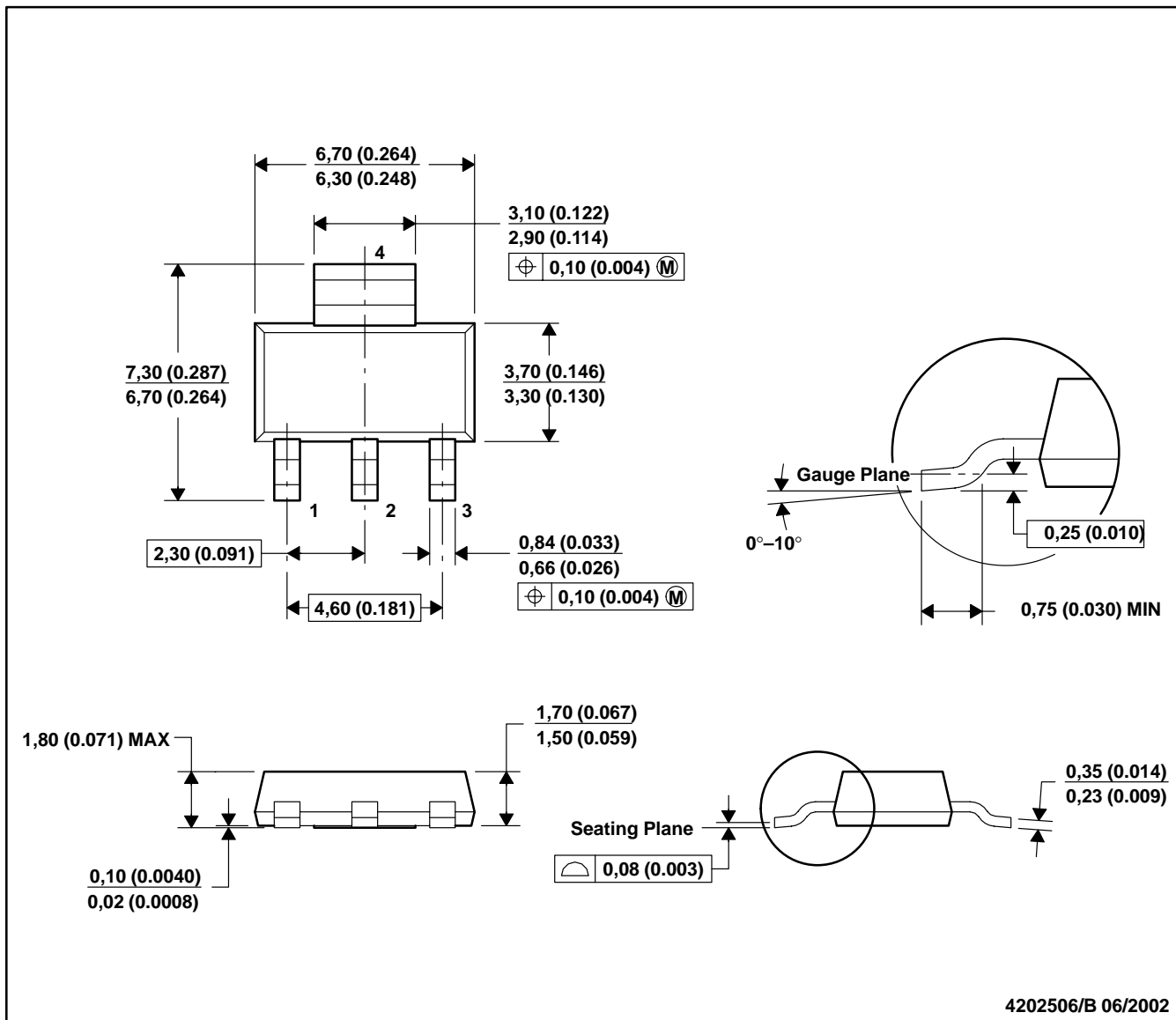

- NOTES: A. All linear dimensions are in millimeters (inches).
 B. This drawing is subject to change without notice.
 C. Body dimensions do not include mold flash or protrusion.
 D. Falls within JEDEC TO-261 Variation AA.

KTP (R-PSFM-G2)

PowerFLEX™ PLASTIC FLANGE-MOUNT PACKAGE

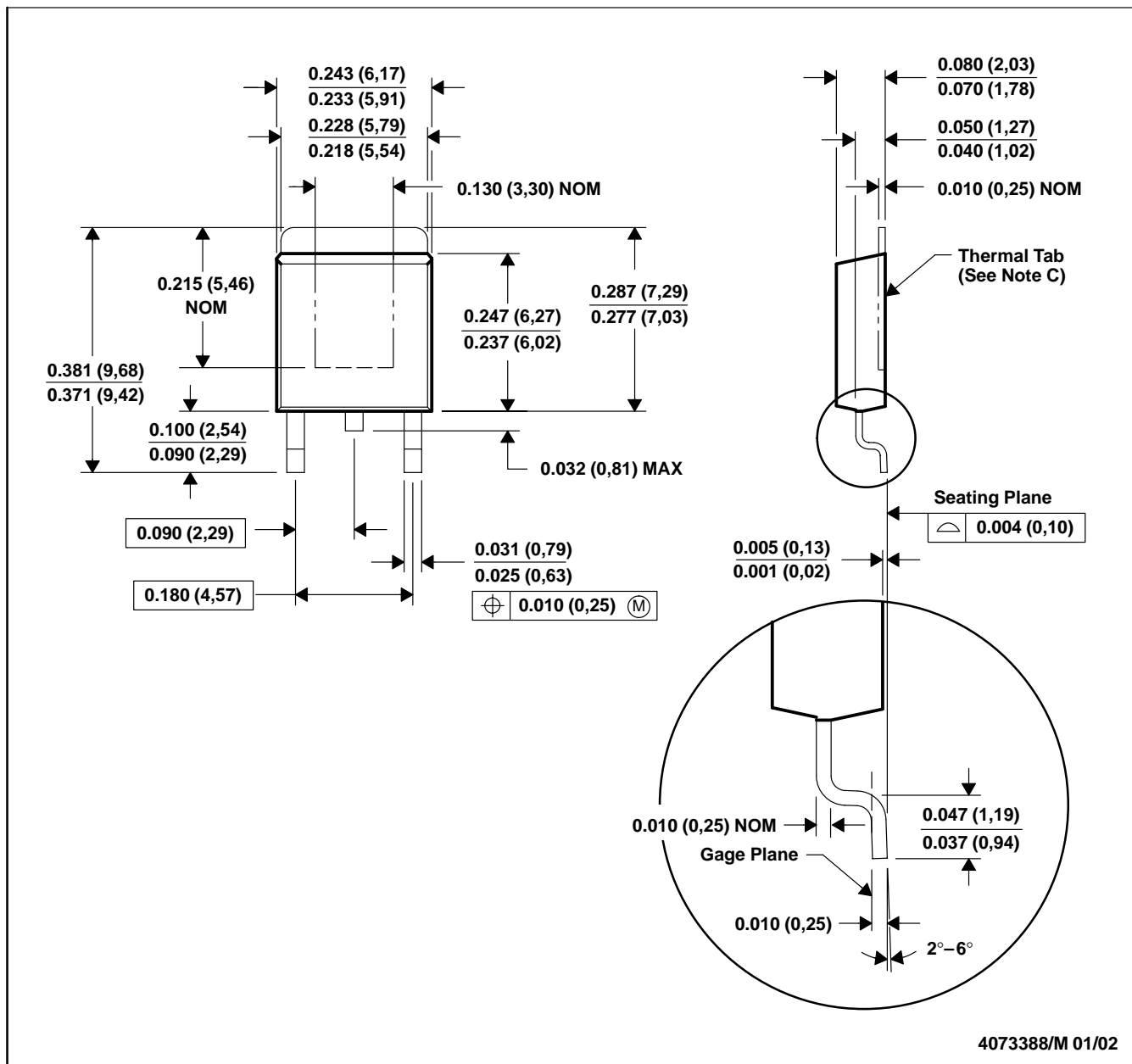

- NOTES: A. All linear dimensions are in inches (millimeters).
 B. This drawing is subject to change without notice.
 C. The center lead is in electrical contact with the thermal tab.
 D. Dimensions do not include mold protrusions, not to exceed 0.006 (0,15).
 E. Falls within JEDEC TO-252 variation AC.

PowerFLEX is a trademark of Texas Instruments.

KTT (R-PSFM-G3)

PLASTIC FLANGE-MOUNT PACKAGE

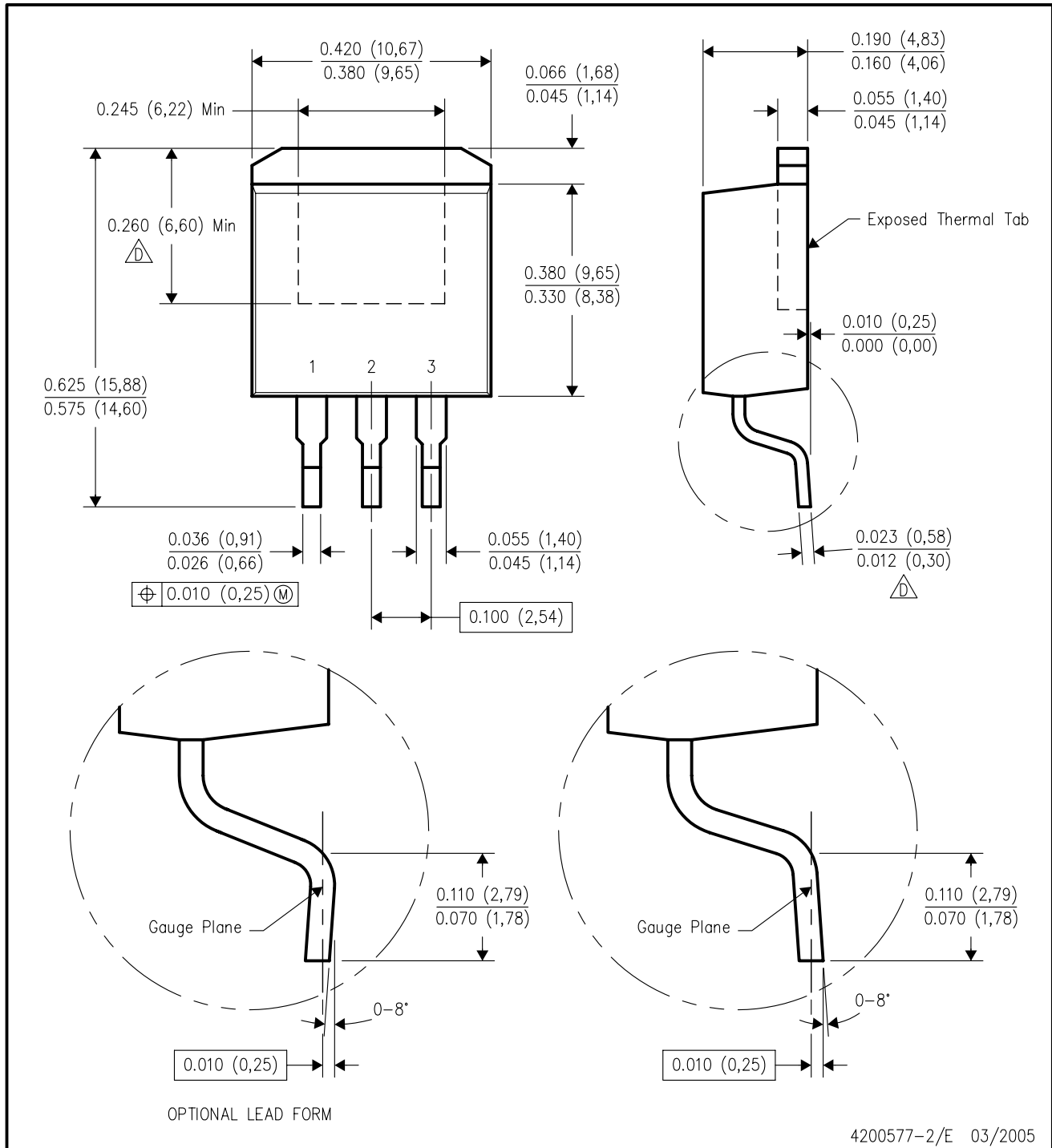

- NOTES:
- A. All linear dimensions are in inches (millimeters).
 - B. This drawing is subject to change without notice.
 - C. Body dimensions do not include mold flash or protrusion. Mold flash or protrusion not to exceed 0.005 (0,13) per side.
- △ Falls within JEDEC TO-263 variation AA, except minimum lead thickness and minimum exposed pad length.

KCS (R-PSFM-T3)

PLASTIC FLANGE-MOUNT PACKAGE

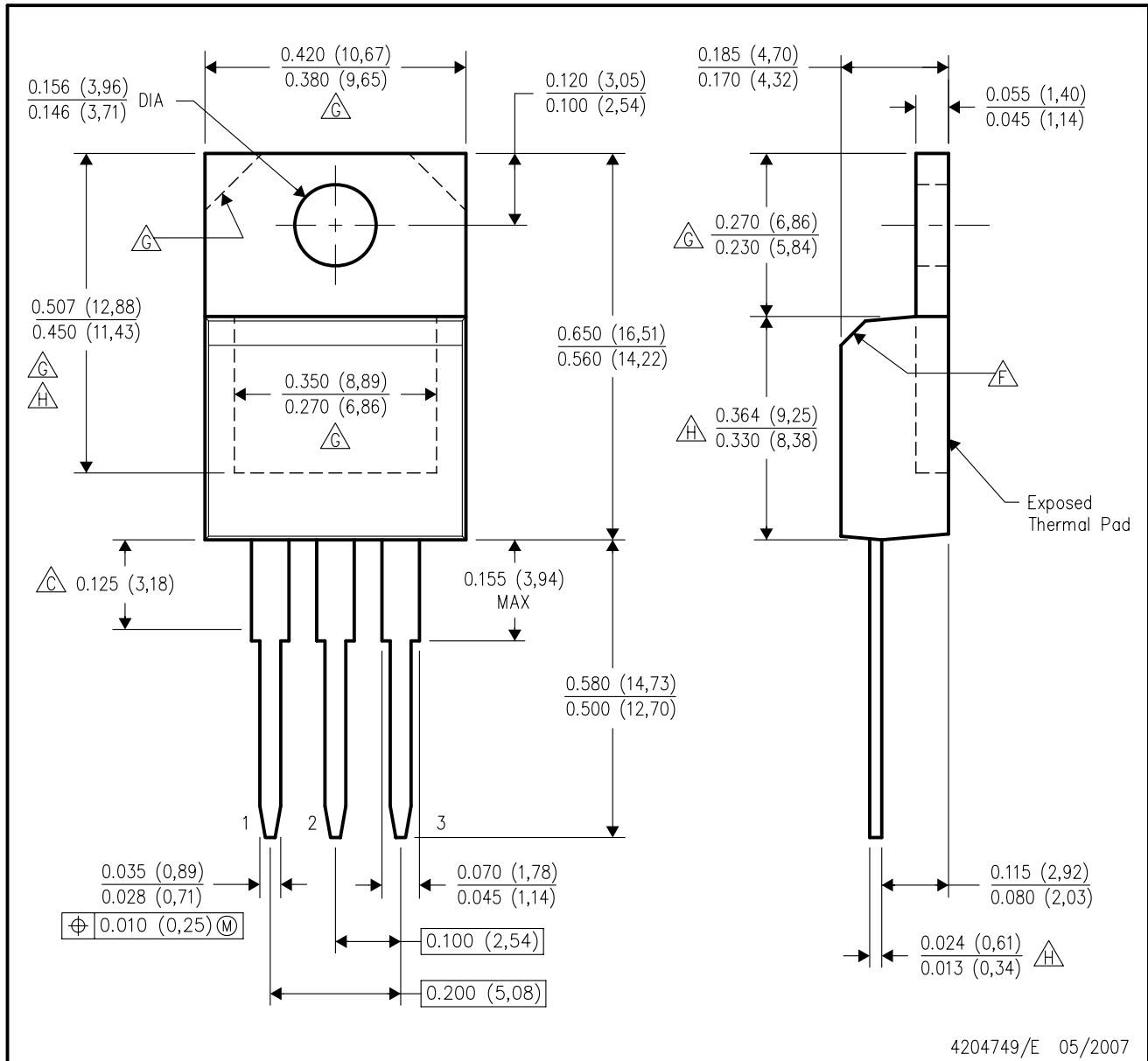

- NOTES:
- A. All linear dimensions are in inches (millimeters).
 - B. This drawing is subject to change without notice.
 - $\triangle C$ Lead dimensions are not controlled within this area.
 - D. All lead dimensions apply before solder dip.
 - E. The center lead is in electrical contact with the mounting tab.
 - $\triangle F$ The chamfer is optional.
 - $\triangle G$ Thermal pad contour optional within these dimensions.
 - $\triangle H$ Falls within JEDEC TO-220 variation AB, except minimum lead thickness, minimum exposed pad length, and maximum body length.

IMPORTANT NOTICE

Texas Instruments Incorporated and its subsidiaries (TI) reserve the right to make corrections, modifications, enhancements, improvements, and other changes to its products and services at any time and to discontinue any product or service without notice. Customers should obtain the latest relevant information before placing orders and should verify that such information is current and complete. All products are sold subject to TI's terms and conditions of sale supplied at the time of order acknowledgment.

TI warrants performance of its hardware products to the specifications applicable at the time of sale in accordance with TI's standard warranty. Testing and other quality control techniques are used to the extent TI deems necessary to support this warranty. Except where mandated by government requirements, testing of all parameters of each product is not necessarily performed.

TI assumes no liability for applications assistance or customer product design. Customers are responsible for their products and applications using TI components. To minimize the risks associated with customer products and applications, customers should provide adequate design and operating safeguards.

TI does not warrant or represent that any license, either express or implied, is granted under any TI patent right, copyright, mask work right, or other TI intellectual property right relating to any combination, machine, or process in which TI products or services are used. Information published by TI regarding third-party products or services does not constitute a license from TI to use such products or services or a warranty or endorsement thereof. Use of such information may require a license from a third party under the patents or other intellectual property of the third party, or a license from TI under the patents or other intellectual property of TI.

Reproduction of TI information in TI data books or data sheets is permissible only if reproduction is without alteration and is accompanied by all associated warranties, conditions, limitations, and notices. Reproduction of this information with alteration is an unfair and deceptive business practice. TI is not responsible or liable for such altered documentation. Information of third parties may be subject to additional restrictions.

Resale of TI products or services with statements different from or beyond the parameters stated by TI for that product or service voids all express and any implied warranties for the associated TI product or service and is an unfair and deceptive business practice. TI is not responsible or liable for any such statements.

TI products are not authorized for use in safety-critical applications (such as life support) where a failure of the TI product would reasonably be expected to cause severe personal injury or death, unless officers of the parties have executed an agreement specifically governing such use. Buyers represent that they have all necessary expertise in the safety and regulatory ramifications of their applications, and acknowledge and agree that they are solely responsible for all legal, regulatory and safety-related requirements concerning their products and any use of TI products in such safety-critical applications, notwithstanding any applications-related information or support that may be provided by TI. Further, Buyers must fully indemnify TI and its representatives against any damages arising out of the use of TI products in such safety-critical applications.

TI products are neither designed nor intended for use in military/aerospace applications or environments unless the TI products are specifically designated by TI as military-grade or "enhanced plastic." Only products designated by TI as military-grade meet military specifications. Buyers acknowledge and agree that any such use of TI products which TI has not designated as military-grade is solely at the Buyer's risk, and that they are solely responsible for compliance with all legal and regulatory requirements in connection with such use.

TI products are neither designed nor intended for use in automotive applications or environments unless the specific TI products are designated by TI as compliant with ISO/TS 16949 requirements. Buyers acknowledge and agree that, if they use any non-designated products in automotive applications, TI will not be responsible for any failure to meet such requirements.

Following are URLs where you can obtain information on other Texas Instruments products and application solutions:

Products		Applications	
Amplifiers	amplifier.ti.com	Audio	www.ti.com/audio
Data Converters	dataconverter.ti.com	Automotive	www.ti.com/automotive
DSP	dsp.ti.com	Broadband	www.ti.com/broadband
Interface	interface.ti.com	Digital Control	www.ti.com/digitalcontrol
Logic	logic.ti.com	Military	www.ti.com/military
Power Mgmt	power.ti.com	Optical Networking	www.ti.com/opticalnetwork
Microcontrollers	microcontroller.ti.com	Security	www.ti.com/security
RFID	www.ti-rfid.com	Telephony	www.ti.com/telephony
Low Power Wireless	www.ti.com/lpw	Video & Imaging	www.ti.com/video
		Wireless	www.ti.com/wireless

Mailing Address: Texas Instruments, Post Office Box 655303, Dallas, Texas 75265
Copyright © 2007, Texas Instruments Incorporated