



CX3HSM CRYSTAL

18 kHz to 600 kHz

Low Profile Surface Mount
Quartz Crystal for Series Oscillators

DESCRIPTION

The CX3HSM quartz crystals are leadless devices designed for surface mounting on printed circuit boards or hybrid substrates. These miniature crystals are intended to be used in Series oscillators. They are hermetically sealed in a rugged, miniature ceramic package. They are manufactured using the STATEK-developed photolithographic process, and were designed utilizing the experience acquired by producing millions of crystals for industrial, commercial, military and medical applications. Maximum process temperature should not exceed 260°C.

FEATURES

- Miniature tuning fork design
- High shock resistance
- Designed for low power applications
- Compatible with hybrid or PC board packaging
- Low aging
- Full military testing available
- Designed and manufactured in the USA

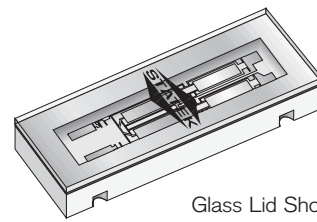

Glass Lid Shown

□ actual size
▭ side view

PACKAGE DIMENSIONS

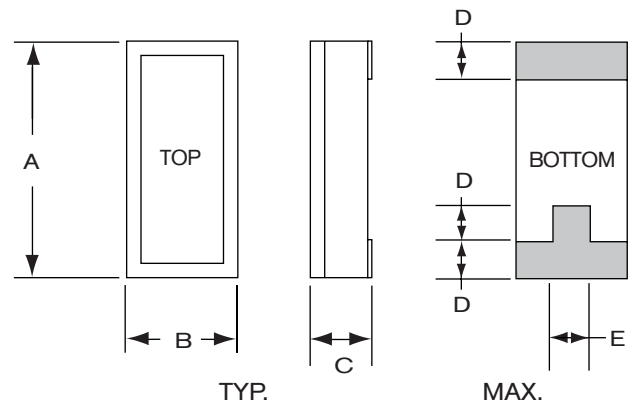

DIM	TYP.		MAX.	
	inches	mm	inches	mm
A	0.263	6.68	0.270	6.86
B	0.097	2.46	0.104	2.64
C	-	-	see below	
D	0.052	1.32	0.058	1.47
E	0.030	0.76	0.035	0.89

DIM "C"	GLASS LID		CERAMIC LID	
	inches	mm	inches	mm
MAX	0.053	1.35	0.067	1.70
SM1	0.055	1.40	0.069	1.75
SM2	0.058	1.47	0.072	1.83

EQUIVALENT CIRCUIT

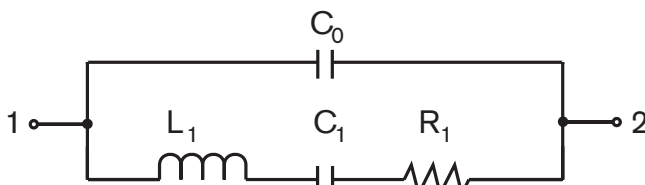

R_1 Motional Resistance L_1 Motional Inductance
 C_1 Motional Capacitance C_0 Shunt Capacitance

SUGGESTED LAND PATTERN

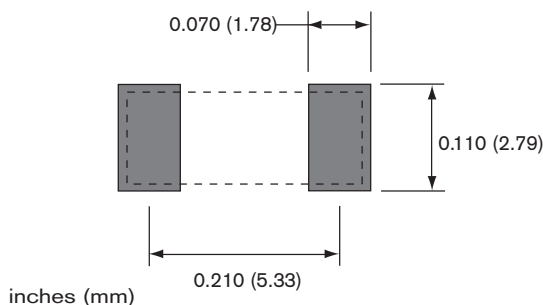

CONVENTIONAL SERIES OSCILLATOR CIRCUIT

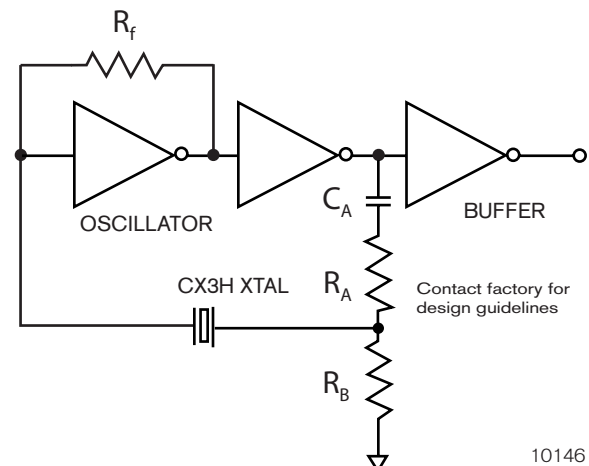

Contact factory for design guidelines

10146 - Rev D



SPECIFICATIONS

Specifications are typical at 25°C unless otherwise noted.

Specifications are subject to change without notice.

Frequency Range	18 kHz to 600 kHz
Functional Mode	Tuning Fork (Flexure)
Standard Calibration Tolerance* (see table below)	
Motional Resistance (R_1)	See Figure 1 MAX: 18-25 kHz, 2x Typ. 25-600 kHz, 2.5x Typ.
Motional Capacitance (C_1)	Figure 2
Quality Factor (Q)	Figure 3 MIN is 0.25x Typ.
Shunt Capacitance (C_0)	1.8 pF MAX.
Drive Level	18-24.9 kHz 0.5 μ W MAX. 25-600 kHz 1.0 μ W MAX.
Turning Point (T_0)**	Figure 4
Temperature Coefficient (k)	-0.035 ppm/°C ²
Aging, first year	5 ppm MAX
Shock, survival***	1,500 g peak, 0.3 ms, 1/2 sine
Vibration, survival***	10 g RMS, 20-2,000 Hz random
Operating Temp. Range	-10°C to +70°C (Commercial) -40°C to +85°C (Industrial) -55°C to +125°C (Military)
Storage Temp. Range	-55°C to +125°C
Max Process Temperature	260°C for 20 sec.

* Other calibration values available, consult factory.

** Other turning point available.

*** Higher shock and vibration available.

CX3H Standard Calibration Tolerance at 25°C

Frequency Range (kHz)		Frequency Range (kHz)	
18-74.9	75-169.9	170-249.9	250-600
± 30 ppm (0.003%)	± 50 ppm (0.005%)	± 100 ppm (0.01%)	±200 ppm (0.02%)
± 100 ppm (0.01%)	± 100 ppm (0.01%)	± 200 ppm (0.02%)	±500 ppm (0.05%)
± 1000 ppm (0.1%)	± 1000 ppm (0.1%)	± 2000 ppm (0.2%)	±5000 ppm (0.5%)

TERMINATIONS

<u>Designation</u>	<u>Termination</u>
SM1	Gold Plated
SM2	Solder Plated
SM3	Solder Dipped

HOW TO ORDER CX3HSM CRYSTALS

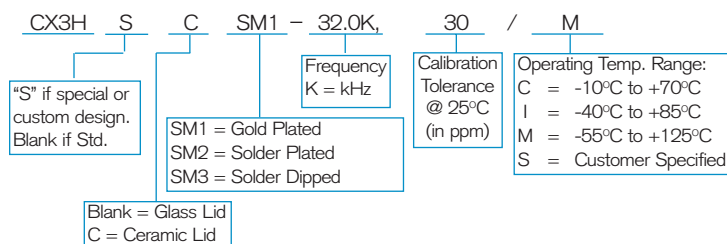

FIGURE 1
CX3H TYPICAL MOTIONAL RESISTANCE (R_1)

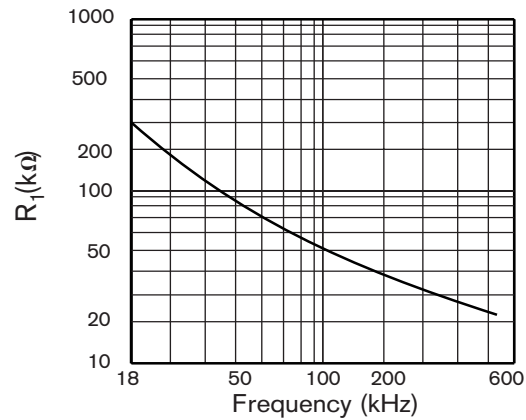

FIGURE 2
CX3H TYPICAL MOTIONAL CAPACITANCE (C_1)

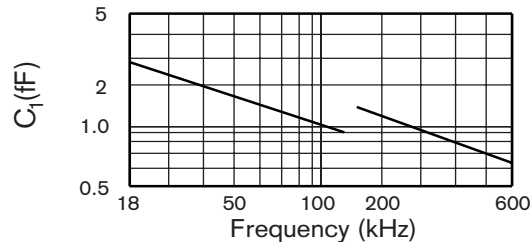

FIGURE 3
CX3H TYPICAL QUALITY FACTOR (Q)

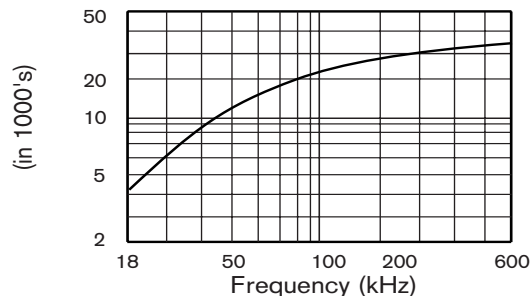
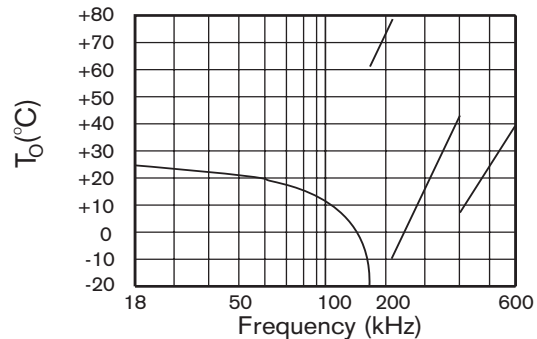

FIGURE 4
CX3H TYPICAL TURNING POINT TEMP. (T_0)



Note: Frequency f at temperature T is related to frequency f_0 at turning point temperature T_0 by:

$$\frac{f-f_0}{f_0} = k(T-T_0)^2$$

PACKAGING OPTIONS

- CX3HSM - Tray Pack
- Tape and Reel
(Reference tape and reel data sheet 10109)