

10 Channel Optical Add/Drop Multiplexer with Band VOAs

Bookham offers a high performance 10 channel optical add/drop multiplexer solution for 100GHz channels. This module's express port allows an upgrade path to 40 channels. Electronic variable optical attenuators (VOAs) with tap/detectors are included for band-by-band loss adjustment.

The Bookham 10 channel solution offers an ideal combination of low loss, compact size, wide channel pass bands and an upgrade path to 40 channels. Specified loss of <5.8dB is achieved in the uniform loss version of the product. Matched mux-demux pairs are also available as a design option. Ribbon connector outputs are available as a design option. Thin film technology provides a flat-topped pass band design that allows for less stringent control of the laser wavelength over the system lifetime.

These flexible upgrade modules use the Bookham 10-skip-0 banded upgrade port. The 10-skip-0 filter passes ten 100GHz spaced channels to the ITU channel filters. The same filter reflects all remaining channels onto the express port with very low loss. Modules can be cascaded to form 20, 30, or 40 channel filter solutions.



Features:

- Flexible upgrade path to 40 channels
- Flat pass band design
- 0.22nm clear pass band
- Low loss (<5.8dB)
- High adjacent channel isolation
- -5 to 70°C operating temperature
- Compact size (135x18x19mm)
- Band loss adjustment
- 0 to 5 Vdc VOA control
- Telcordia GR-1221 qualified
- RoHS compliant 

Options:

- Ribbon connectors
- Uniform loss or matched mux/demux loss
- Tap/detector before and/or after VOA
- Without 10-skip-0 filter
- Rack mount or LGX enclosure

Applications:

- Metro and long-haul mux/demux
- OADM nodes
- Subsystem building block

10 Channel Add/Drop Multiplexer with Band VOAs; 100GHz Channels

Specifications (valid over operating temperature)

Module Parameters	Region	Measure from => to	Specification	Unit	
Number of Channels			10		
Channel Spacing			100	GHz	
Channel Frequency	option 20		ITU Z to ITU Z+9	GHz	
Passband Region			ITU ± 0.11	nm	
Insertion Loss ^[1]	Passband	Common => Ports 1-10	5.8	Max	dB
		Common => Express	0.9	Max	dB
IL Variation	Passbands	Common => Ports 1-10	0.5	Max	dB
Channel to Channel Variation	Passband	Common => Ports 1-10	1.0	Max	dB
Isolation	Adj Ch	Common => Ports 1-10	25	Min	dB
	Non-Adj Ch	Common => Ports 1-10	40	Min	dB
	Add/Drop	Common => Express	13	Min	dB
Return Loss			45	Min	dB
Polarization Dependant Loss			0.25	Max	dB
Polarization Mode Dispersion			0.4	Max	ps
Power Handling			300	Min	mW
Operating Temperature			-5 to 70	°C	
Storage Temperature			-40 to 85	°C	
Dimensions			135x81x19	mm	

[1] Losses include connectors, taps and VOAs at minimum attenuation.

VOA Parameters	Specification	Unit	
VOA Mode	Normally Dark		
Attenuation Range	30	min	dB
Response Time	10	max	ms
Control Voltage	5	max	Vdc
Minimum Attenuation Voltage	4.7 ± 0.3		Vdc

Tap/Detector Parameters	Specification	Unit
Tap Ratio	5/95	
Responsivity	45	min uA/m W
Linearity	±10	%
Operating Bias Voltage	5	V

Functional Diagram

Example of typical module configuration

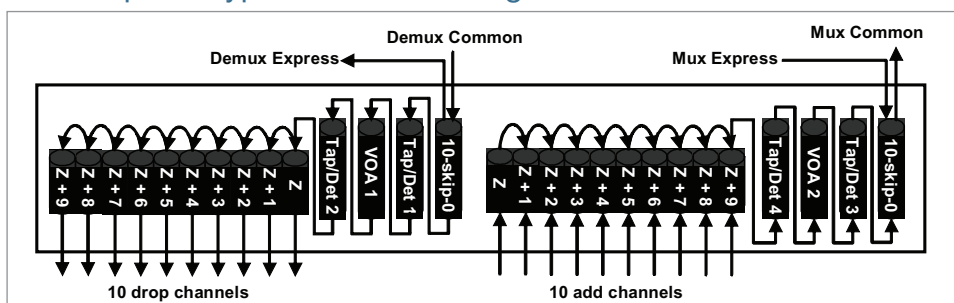

RoHS Compliance

Bookham is fully committed to environment protection and sustainable development and has set in place a comprehensive program for removing polluting and hazardous substances from all of its products.

The relevant evidence of RoHS compliance is held as part of our controlled documentation for each of our compliant products. RoHS compliance parts are available to order, please refer to the ordering information section for further details.

Ordering Information:

MC1C10__0292

Channel Plan

<i>Band (THz)</i>	<i>Channel Plan</i>
192.0 to 192.9	20
193.0 to 193.9	30
194.0 to 194.9	40
195.0 to 195.9	50

Part numbers may change depending on optional configurations chosen including connectors, pigtailed, tap ports and final optical function.

Contact Information

North America Santa Rosa Office

3640 Westwind Boulevard
Santa Rosa
CA 95403
USA

- Tel: +1 707 636 1100
- Fax: +1 707 636 1199

www.bookham.com
sales@bookham.com

Europe Paignton Office

Brixham Road
Paignton
Devon
TQ4 7BE
United Kingdom

- Tel: +44 (0) 1803 66 2000
- Fax: +44 (0) 1803 66 2801

Asia Shenzhen Office

2 Phoenix Road
Futian Free Trade Zone
Shenzhen 518038
China

- Tel: +86 755 33305888
- Fax: +86 755 33305805
+86 755 33305807

Important Notice

Performance figures, data and any illustrative material provided in this data sheet are typical and must be specifically confirmed in writing by Bookham before they become applicable to any particular order or contract. In accordance with the Bookham policy of continuous improvement specifications may change without notice. The publication of information in this data sheet does not imply freedom from patent or other protective rights of Bookham or others. Further details are available from any Bookham sales representative.