

SKiiP 25NAB065V10



MiniSKiiP® 2

3-phase bridge rectifier +
brake chopper + 3-phase
bridge inverter
SKiiP 25NAB065V10

Preliminary Data

Features

- Ultrafast NPT IGBTs
- Robust and soft freewheeling diodes in CAL technology
- Highly reliable spring contacts for electrical connections
- UL recognised file no. E63532

Typical Applications

- Inverter up to 10 kVA
- Typical motor power 4,0 kW

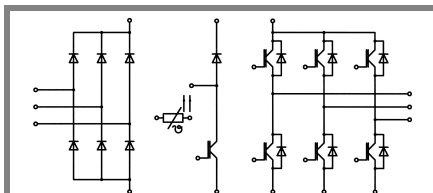

NAB

Absolute Maximum Ratings		$T_s = 25\text{ °C}$, unless otherwise specified	
Symbol	Conditions	Values	Units
IGBT - Inverter, Chopper			
V_{CES}		600	V
I_C	$T_s = 25\text{ (70) °C}$	38 (28)	A
I_{CRM}	$T_s = 25\text{ (70) °C}$, $t_p \leq 1\text{ ms}$	76 (56)	A
V_{GES}		± 20	V
T_j		- 40 ... + 150	°C
Diode - Inverter, Chopper			
I_F	$T_s = 25\text{ (70) °C}$	40 (30)	A
I_{FRM}	$T_s = 25\text{ (70) °C}$, $t_p \leq 1\text{ ms}$	80 (60)	A
T_j		- 40 ... + 150	°C
Diode - Rectifier			
V_{RRM}		800	V
I_F	$T_s = 70\text{ °C}$	46	A
I_{FSM}	$t_p = 10\text{ ms}$, $\sin 180\text{ °}$, $T_j = 25\text{ °C}$	370	A
i^2t	$t_p = 10\text{ ms}$, $\sin 180\text{ °}$, $T_j = 25\text{ °C}$	680	A ² s
T_j		- 40 ... + 150	°C
I_{tRMS}	per power terminal (20 A / spring)	60	A
T_{stg}	$T_{op} \leq T_{stg}$	- 40 ... + 125	°C
V_{isol}	AC, 1 min.	2500	V

Characteristics		$T_s = 25\text{ °C}$, unless otherwise specified			
Symbol	Conditions	min.	typ.	max.	Units
IGBT - Inverter, Chopper					
V_{CEsat}	$I_C = 30\text{ A}$, $T_j = 25\text{ (125) °C}$		2 (2,2)	2,5 (2,7)	V
$V_{GE(th)}$	$V_{GE} = V_{CE}$, $I_C = 0,5\text{ mA}$	3	4	5	V
$V_{CE(TO)}$	$T_j = 25\text{ (125) °C}$		1,2 (1,1)	1,3 (1,2)	V
r_T	$T_j = 25\text{ (125) °C}$		27 (37)	40 (50)	mΩ
C_{ies}	$V_{CE} = 25\text{ V}$, $V_{GE} = 0\text{ V}$, $f = 1\text{ MHz}$		1,5		nF
C_{oes}	$V_{CE} = 25\text{ V}$, $V_{GE} = 0\text{ V}$, $f = 1\text{ MHz}$		0,2		nF
C_{res}	$V_{CE} = 25\text{ V}$, $V_{GE} = 0\text{ V}$, $f = 1\text{ MHz}$		0,1		nF
$R_{th(j-s)}$	per IGBT		1,05		K/W
$t_{d(on)}$	under following conditions		20		ns
t_r	$V_{CC} = 300\text{ V}$, $V_{GE} = \pm 15\text{ V}$		20		ns
$t_{d(off)}$	$I_C = 30\text{ A}$, $T_j = 125\text{ °C}$		180		ns
t_f	$R_{Gon} = R_{Goff} = 20\text{ Ω}$		20		ns
E_{on}	inductive load		0,9		mJ
E_{off}			0,65		mJ
Diode - Inverter, Chopper					
$V_F = V_{EC}$	$I_F = 30\text{ A}$, $T_j = 25\text{ (125) °C}$		1,5 (1,5)	1,8 (1,8)	V
$V_{(TO)}$	$T_j = 25\text{ (125) °C}$		1 (0,9)	1,1 (1)	V
r_T	$T_j = 25\text{ (125) °C}$		18 (20)	23 (27)	mΩ
$R_{th(j-s)}$	per diode		1,5		K/W
I_{RRM}	under following conditions		58		A
Q_{rr}	$I_F = 30\text{ A}$, $V_R = 300\text{ V}$		3,5		μC
E_{rr}	$V_{GE} = 0\text{ V}$, $T_j = 125\text{ °C}$		0,8		mJ
	$di_F/dt = 2500\text{ A/μs}$				
Diode - Rectifier					
V_F	$I_F = 25\text{ A}$, $T_j = 25\text{ °C}$		1,1		V
$V_{(TO)}$	$T_j = 150\text{ °C}$		0,8		V
r_T	$T_j = 150\text{ °C}$		13		mΩ
$R_{th(j-s)}$	per diode		1,25		K/W
Temperature Sensor					
R_{ts}	3 %, $T_r = 25\text{ (100) °C}$		1000(1670)		Ω
Mechanical Data					
w			65		g
M_s	Mounting torque	2		2,5	Nm

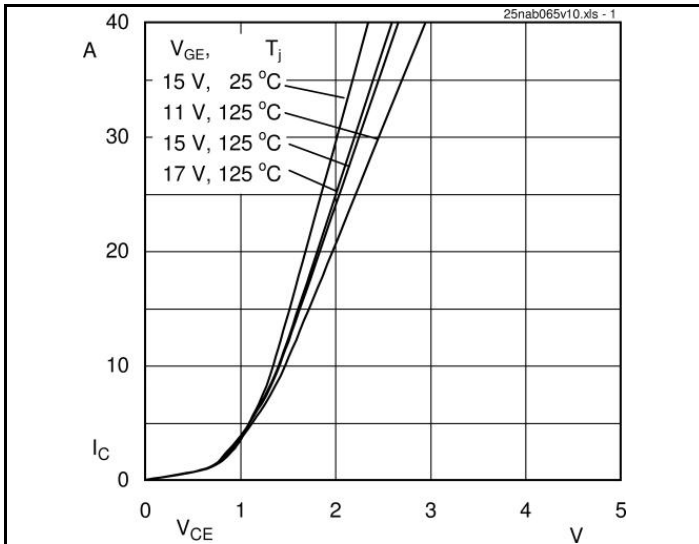

Fig. 1 Typ. output characteristic

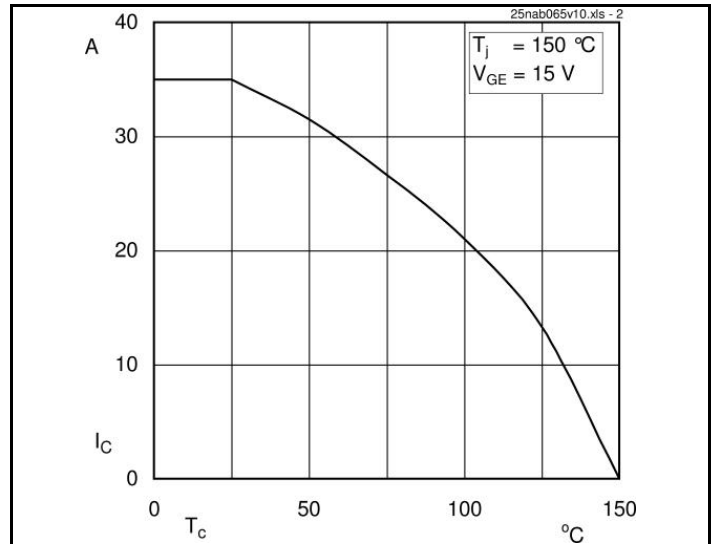

Fig. 2 Typ. rated current vs. temperature

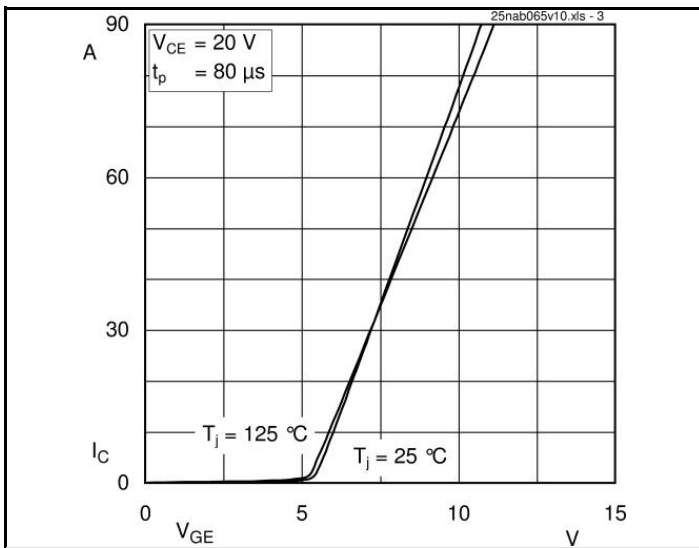

Fig. 3 Typ. transfer characteristic

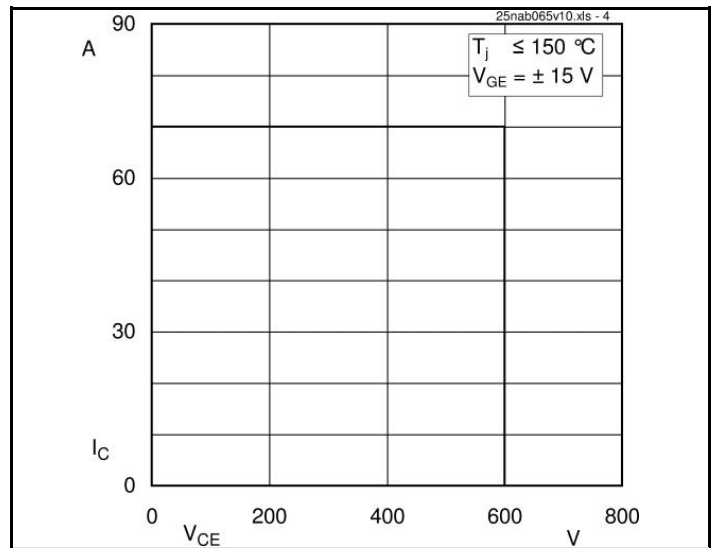

Fig. 4 Reverse bias safe operating area

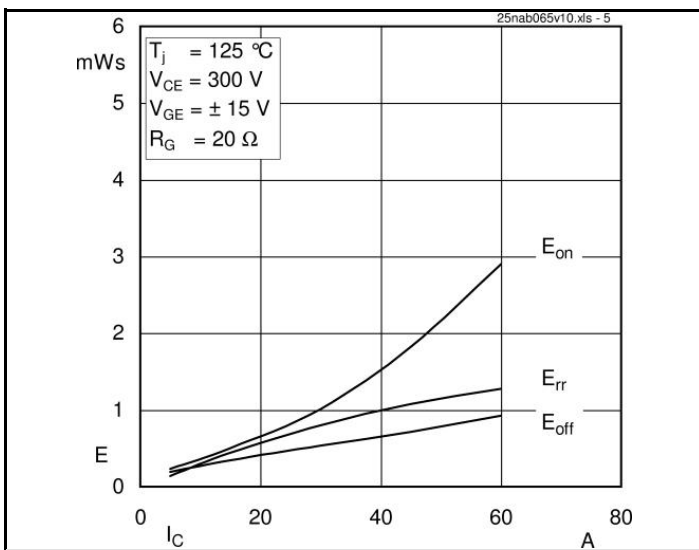

Fig. 5 Typ. Turn-on /-off energy = $f(I_C)$

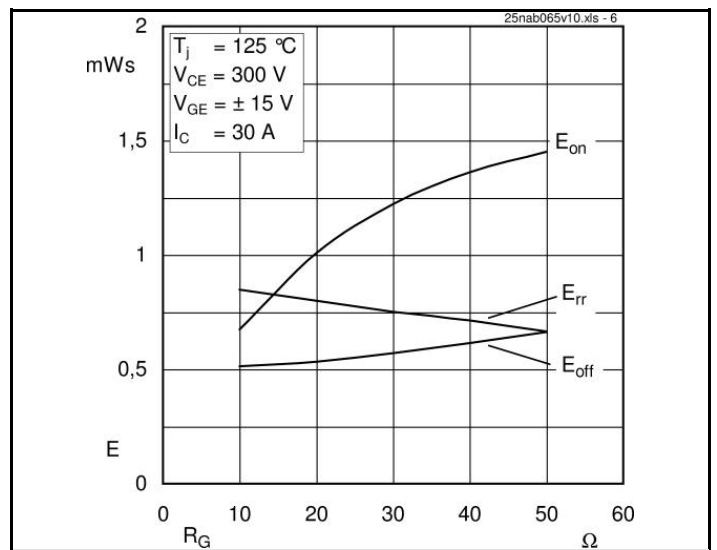
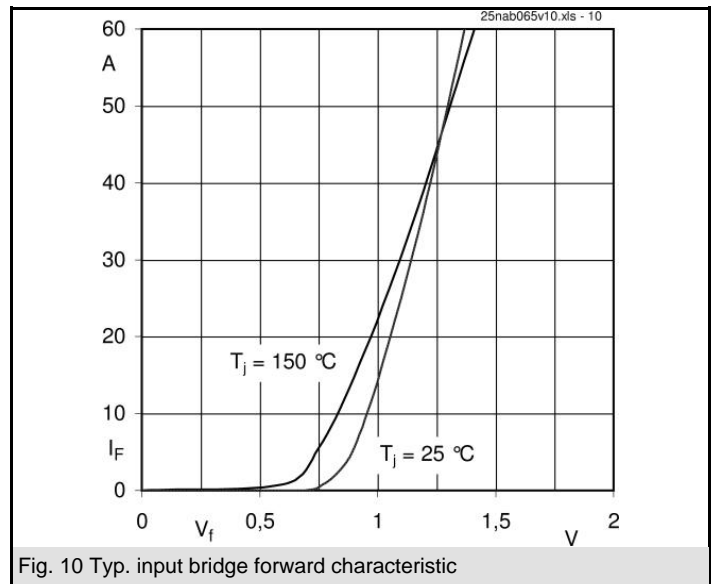
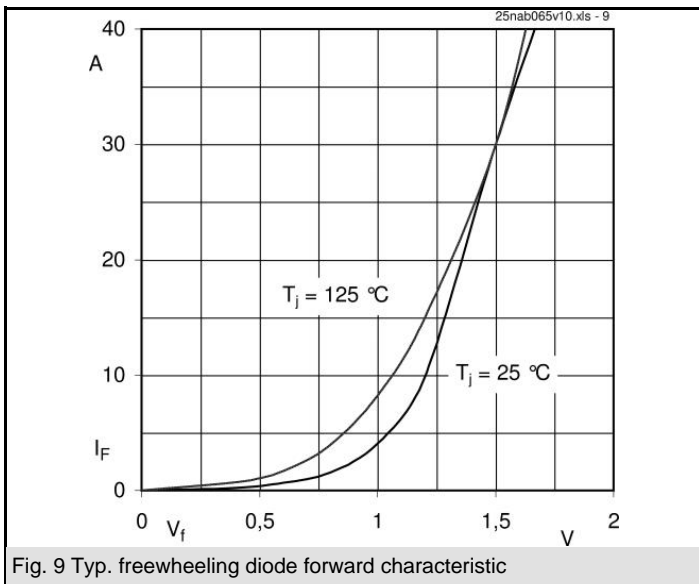
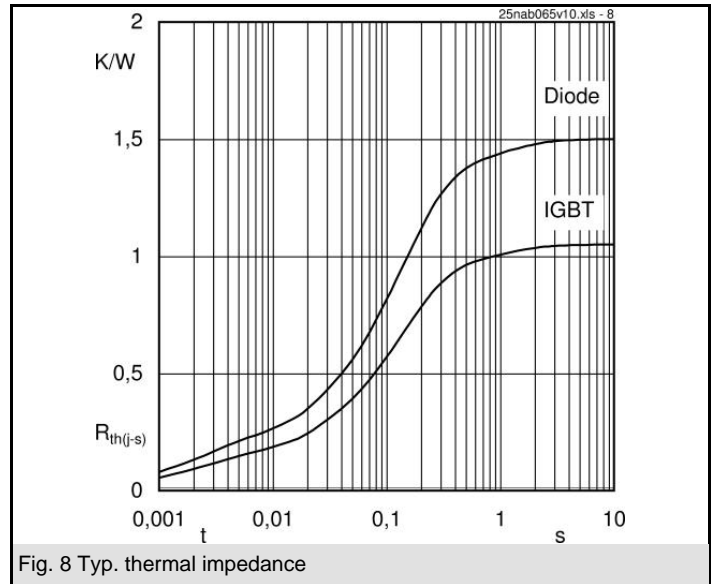
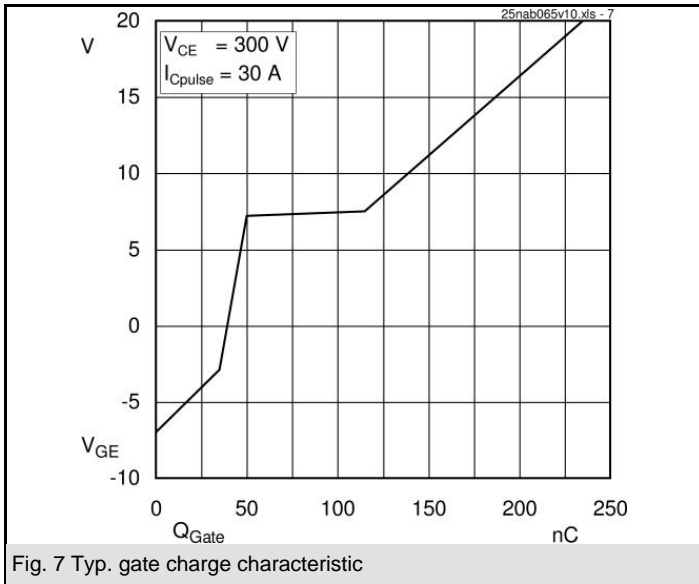
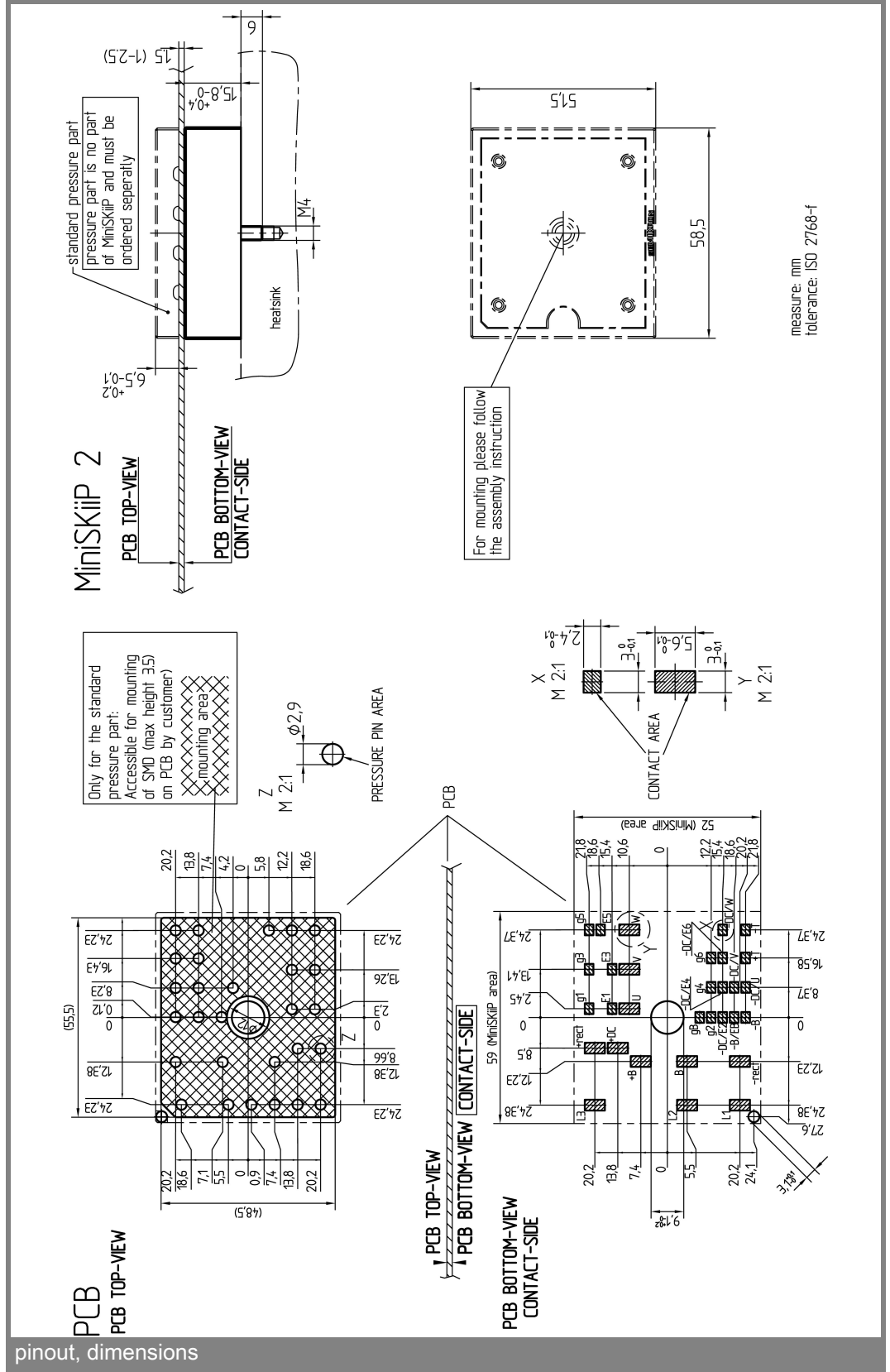
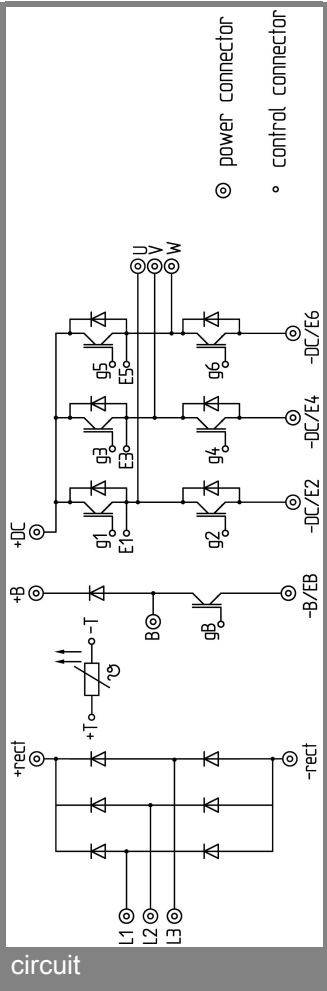

Fig. 6 Typ. Turn-on /-off energy = $f(R_G)$





This is an electrostatic discharge sensitive device (ESDS), international standard IEC 60747-1, Chapter IX.

This technical information specifies semiconductor devices but promises no characteristics. No warranty or guarantee expressed or implied is made regarding delivery, performance or suitability.