

TOSHIBA CMOS Digital Integrated Circuit Silicon Monolithic

TC74HC377AP, TC74HC377AF

Octal D-Type Flip-Flop

The TC74HC377A is a high speed CMOS OCTAL D-TYPE FLIP-FLOP fabricated with silicon gate C²MOS technology.

It achieves the high speed operation similar to equivalent LSTTL while maintaining the CMOS low power dissipation.

This 8-bit D-type flip-flop is controlled by a clock input (CK) and an output enable input (\overline{G}).

The signal level applied to the D inputs are transferred to Q outputs during the positive going transition of CK.

When the \overline{G} is high, the eight outputs are in a high impedance state.

All inputs are equipped with protection circuits against static discharge or transient excess voltage.

Features

- High speed: $f_{max} = 73$ MHz (typ.) at $V_{CC} = 5$ V
- Low power dissipation: $I_{CC} = 4$ μ A (max) at $T_a = 25^\circ$ C
- High noise immunity: $V_{NIH} = V_{NIL} = 28\%$ V_{CC} (min)
- Output drive capability: 10 LSTTL loads
- Symmetrical output impedance: $|I_{OH}| = I_{OL} = 4$ mA (min)
- Balanced propagation delays: $t_{pLH} \approx t_{pHL}$
- Wide operating voltage range: V_{CC} (opr) = 2 to 6 V
- Pin and function compatible with 74LS377

Pin Assignment

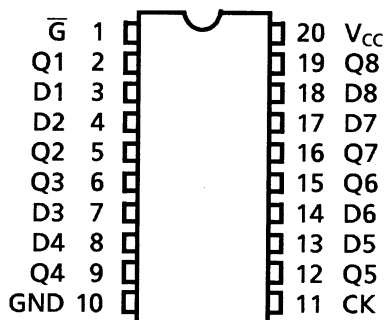

(TOP VIEW)

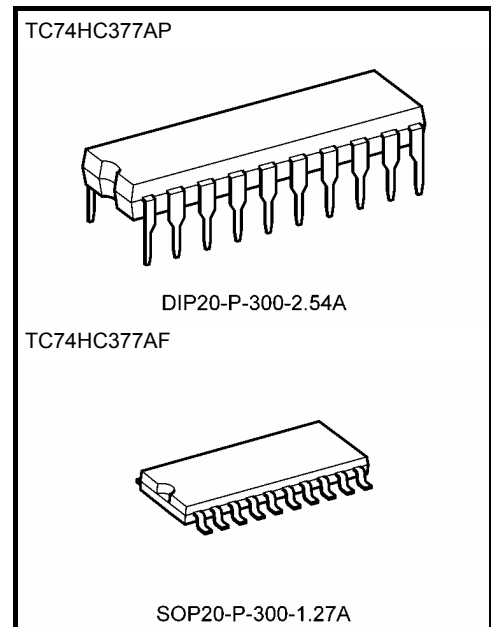

Weight



DIP20-P-300-2.54A : 1.30 g (typ.)

SOP20-P-300-1.27A : 0.22 g (typ.)

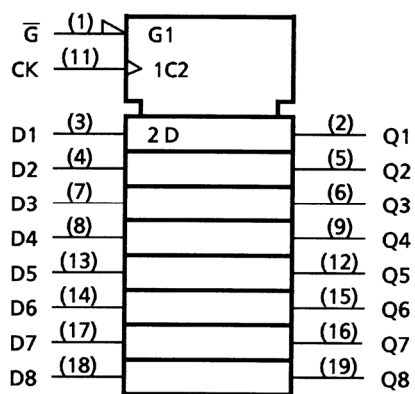
IEC Logic Symbol



Truth Table

Inputs			Outputs
\bar{G}	CK	D	Q
H	X	X	No Change
L		L	L
L		H	H
X		X	No Change

X: Don't care

System Diagram

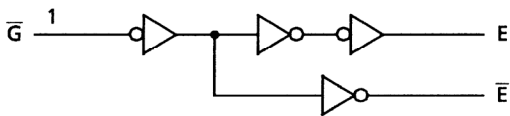
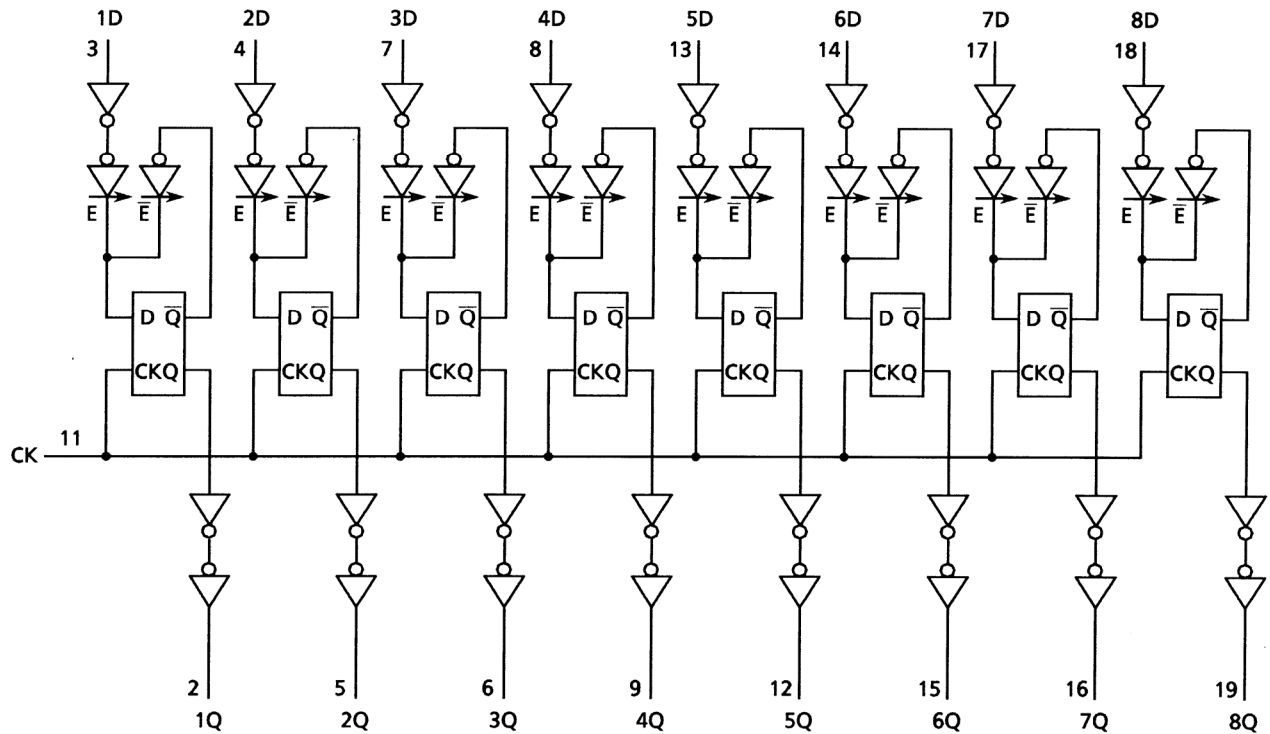

Absolute Maximum Ratings (Note 1)

Characteristics	Symbol	Rating	Unit
Supply voltage range	V_{CC}	-0.5 to 7	V
DC input voltage	V_{IN}	-0.5 to $V_{CC} + 0.5$	V
DC output voltage	V_{OUT}	-0.5 to $V_{CC} + 0.5$	V
Input diode current	I_{IK}	± 20	mA
Output diode current	I_{OK}	± 20	mA
DC output current	I_{OUT}	± 25	mA
DC V_{CC} /ground current	I_{CC}	± 50	mA
Power dissipation	P_D	500 (DIP) (Note 2)/180 (SOP)	mW
Storage temperature	T_{stg}	-65 to 150	$^{\circ}C$

Note 1: Exceeding any of the absolute maximum ratings, even briefly, lead to deterioration in IC performance or even destruction.

Using continuously under heavy loads (e.g. the application of high temperature/current/voltage and the significant change in temperature, etc.) may cause this product to decrease in the reliability significantly even if the operating conditions (i.e. operating temperature/current/voltage, etc.) are within the absolute maximum ratings and the operating ranges.

Please design the appropriate reliability upon reviewing the Toshiba Semiconductor Reliability Handbook ("Handling Precautions"/"Derating Concept and Methods") and individual reliability data (i.e. reliability test report and estimated failure rate, etc).

Note 2: 500 mW in the range of $T_a = -40$ to $65^{\circ}C$. From $T_a = 65$ to $85^{\circ}C$ a derating factor of -10 mW/ $^{\circ}C$ shall be applied until 300 mW.

Operating Ranges (Note)

Characteristics	Symbol	Rating	Unit
Supply voltage	V_{CC}	2 to 6	V
Input voltage	V_{IN}	0 to V_{CC}	V
Output voltage	V_{OUT}	0 to V_{CC}	V
Operating temperature	T_{opr}	-40 to 85	°C
Input rise and fall time	t_r, t_f	0 to 1000 ($V_{CC} = 2.0$ V) 0 to 500 ($V_{CC} = 4.5$ V) 0 to 400 ($V_{CC} = 6.0$ V)	ns

Note: The operating ranges must be maintained to ensure the normal operation of the device. Unused inputs must be tied to either VCC or GND.

Electrical Characteristics

DC Characteristics

Characteristics	Symbol	Test Condition	$T_a = 25^\circ\text{C}$			$T_a = -40$ to 85°C		Unit		
			V_{CC} (V)	Min	Typ.	Max	Min		Max	
High-level input voltage	V_{IH}	—	2.0	1.50	—	—	1.50	—	V	
			4.5	3.15	—	—	3.15	—		
			6.0	4.20	—	—	4.20	—		
Low-level input voltage	V_{IL}	—	2.0	—	—	0.50	—	0.50	V	
			4.5	—	—	1.35	—	1.35		
			6.0	—	—	1.80	—	1.80		
High-level output voltage	V_{OH}	$V_{IN} = V_{IH}$	$I_{OH} = -20 \mu\text{A}$	2.0	1.9	2.0	—	1.9	—	V
				4.5	4.4	4.5	—	4.4	—	
				6.0	5.9	6.0	—	5.9	—	
			$I_{OH} = -4 \text{ mA}$	4.5	4.18	4.31	—	4.13	—	
		$I_{OH} = -5.2 \text{ mA}$	6.0	5.68	5.80	—	5.63	—		
Low-level output voltage	V_{OL}	$V_{IN} = V_{IL}$	$I_{OL} = 20 \mu\text{A}$	2.0	—	0.0	0.1	—	0.1	V
				4.5	—	0.0	0.1	—	0.1	
				6.0	—	0.0	0.1	—	0.1	
			$I_{OL} = 4 \text{ mA}$	4.5	—	0.17	0.26	—	0.33	
		$I_{OL} = 5.2 \text{ mA}$	6.0	—	0.18	0.26	—	0.33		
Input leakage current	I_{IN}	$V_{IN} = V_{CC}$ or GND	6.0	—	—	± 0.1	—	± 1.0	μA	
Quiescent supply current	I_{CC}	$V_{IN} = V_{CC}$ or GND	6.0	—	—	4.0	—	40.0	μA	

Timing Requirements (input: $t_r = t_f = 6 \text{ ns}$)

Characteristics	Symbol	Test Condition	Ta = 25°C		Ta = -40 to 85°C		Unit
			V _{CC} (V)	Typ.	Limit	Limit	
Minimum pulse width (CK)	t_W (H) t_W (L)	—	2.0	—	75	95	ns
			4.5	—	15	19	
			6.0	—	13	16	
Minimum set-up time (D-CK)	t_s	—	2.0	—	75	95	ns
			4.5	—	15	19	
			6.0	—	13	16	
Minimum set-up time (\bar{G} -CK)	t_s	—	2.0	—	75	95	ns
			4.5	—	15	19	
			6.0	—	13	16	
Minimum hold time	t_h	—	2.0	—	0	0	ns
			4.5	—	0	0	
			6.0	—	0	0	
Clock frequency	f	—	2.0	—	7	6	MHz
			4.5	—	36	29	
			6.0	—	42	34	

AC Characteristics (C_L = 15 pF, V_{CC} = 5 V, Ta = 25°C, input: $t_r = t_f = 6 \text{ ns}$)

Characteristics	Symbol	Test Condition	Min	Typ.	Max	Unit
Output transition time	t_{TLH}	—	—	4	8	ns
	t_{THL}					
Propagation delay time (CK-Q)	t_{pLH}	—	—	14	24	ns
	t_{pHL}					
Maximum clock frequency	f_{max}	—	38	73	—	MHz

AC Characteristics ($C_L = 50 \text{ pF}$, input: $t_r = t_f = 6 \text{ ns}$)

Characteristics	Symbol	Test Condition	Ta = 25°C			Ta = -40 to 85°C		Unit	
			V _{CC} (V)	Min	Typ.	Max	Min		Max
Output transition time	t_{TLH} t_{THL}	—	2.0	—	30	75	—	95	ns
			4.5	—	8	15	—	19	
			6.0	—	7	13	—	16	
Propagation delay time (CK-Q)	t_{pLH} t_{pHL}	—	2.0	—	57	140	—	175	ns
			4.5	—	17	28	—	35	
			6.0	—	13	24	—	30	
Maximum clock frequency	f_{max}	—	2.0	7	18	—	6	—	MHz
			4.5	36	59	—	29	—	
			6.0	42	77	—	34	—	
Input capacitance	C_{IN}	—	—	5	10	—	10	pF	
Power dissipation capacitance	C_{PD} (Note)	—	—	32	—	—	—	pF	

Note: C_{PD} is defined as the value of the internal equivalent capacitance which is calculated from the operating current consumption without load.

Average operating current can be obtained by the equation:

$$I_{CC}(\text{opr}) = C_{PD} \cdot V_{CC} \cdot f_{IN} + I_{CC}/8 \text{ (per flip flop)}$$

And the total C_{PD} when n pcs. of flip flop operate can be gained by the following equation:

$$C_{PD}(\text{total}) = 22 + 10 \cdot n$$

Package Dimensions

DIP20-P-300-2.54A

Unit : mm

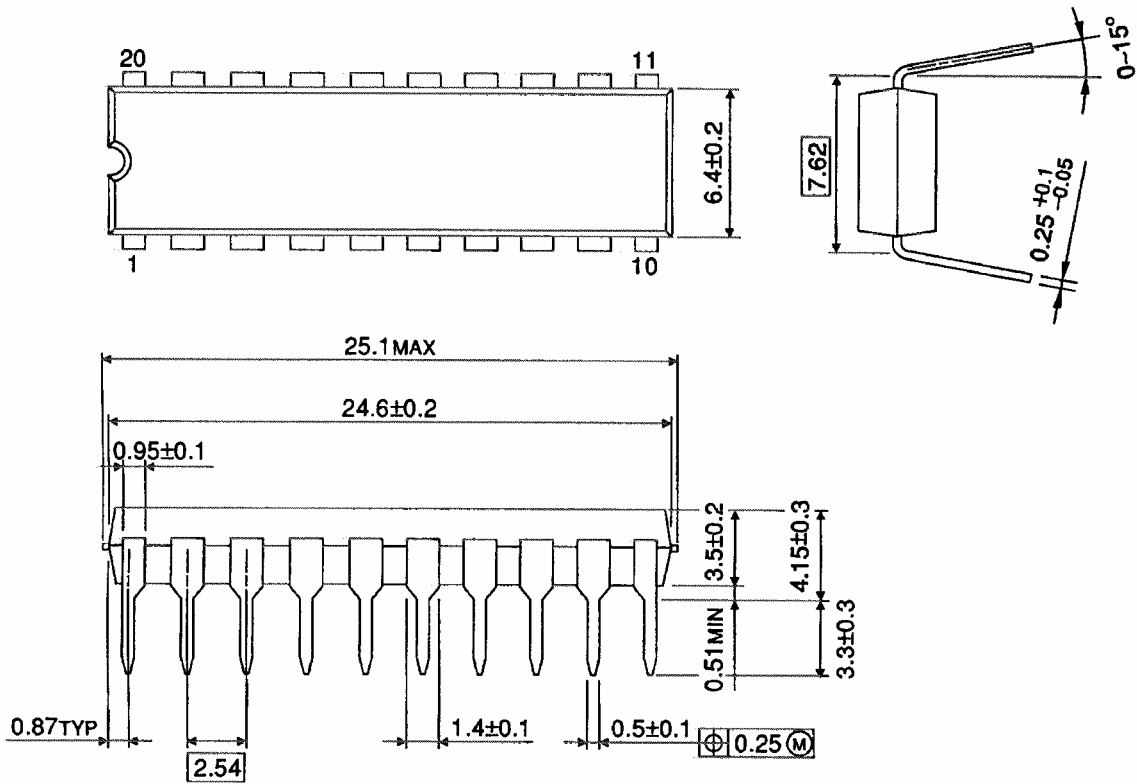

Weight: 1.30 g (typ.)

Package Dimensions

SOP20-P-300-1.27A

Unit: mm

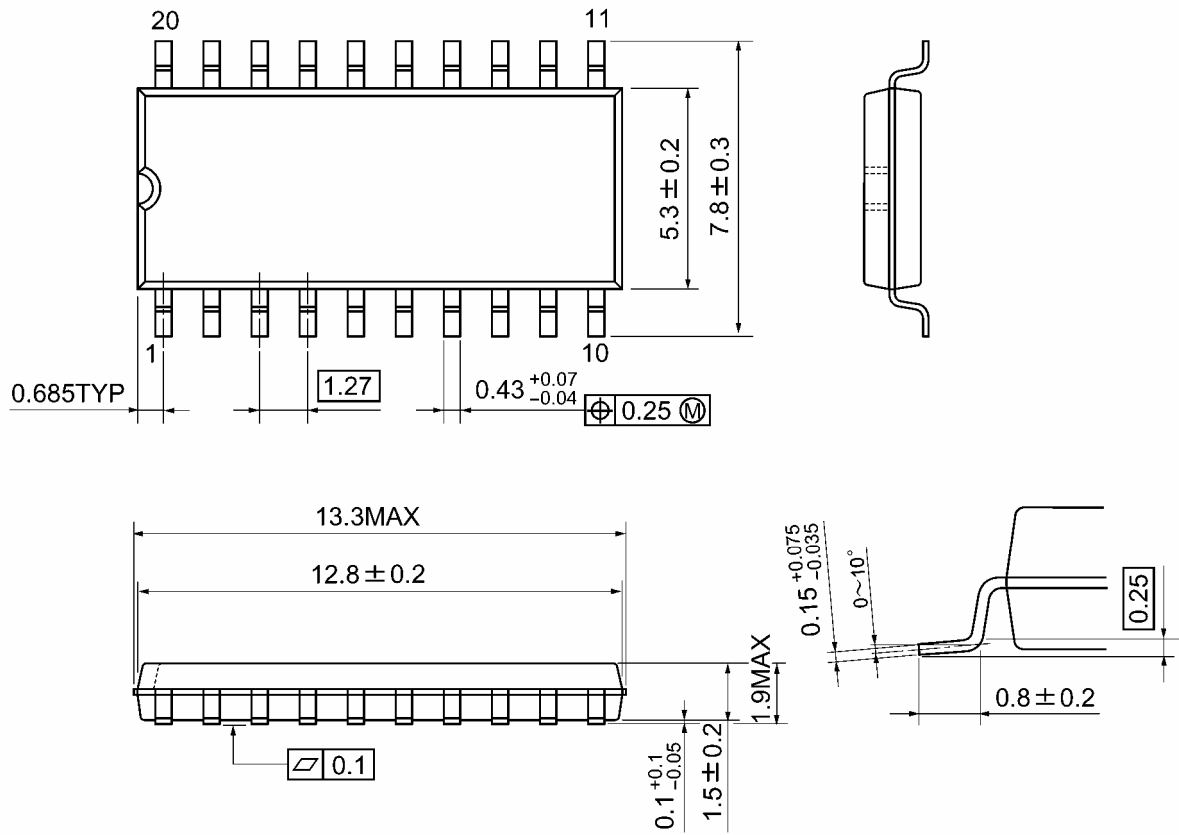

Weight: 0.22 g (typ.)

RESTRICTIONS ON PRODUCT USE

20070701-EN GENERAL

- The information contained herein is subject to change without notice.
- TOSHIBA is continually working to improve the quality and reliability of its products. Nevertheless, semiconductor devices in general can malfunction or fail due to their inherent electrical sensitivity and vulnerability to physical stress. It is the responsibility of the buyer, when utilizing TOSHIBA products, to comply with the standards of safety in making a safe design for the entire system, and to avoid situations in which a malfunction or failure of such TOSHIBA products could cause loss of human life, bodily injury or damage to property.
In developing your designs, please ensure that TOSHIBA products are used within specified operating ranges as set forth in the most recent TOSHIBA products specifications. Also, please keep in mind the precautions and conditions set forth in the "Handling Guide for Semiconductor Devices," or "TOSHIBA Semiconductor Reliability Handbook" etc.
- The TOSHIBA products listed in this document are intended for usage in general electronics applications (computer, personal equipment, office equipment, measuring equipment, industrial robotics, domestic appliances, etc.). These TOSHIBA products are neither intended nor warranted for usage in equipment that requires extraordinarily high quality and/or reliability or a malfunction or failure of which may cause loss of human life or bodily injury ("Unintended Usage"). Unintended Usage include atomic energy control instruments, airplane or spaceship instruments, transportation instruments, traffic signal instruments, combustion control instruments, medical instruments, all types of safety devices, etc.. Unintended Usage of TOSHIBA products listed in this document shall be made at the customer's own risk.
- The products described in this document shall not be used or embedded to any downstream products of which manufacture, use and/or sale are prohibited under any applicable laws and regulations.
- The information contained herein is presented only as a guide for the applications of our products. No responsibility is assumed by TOSHIBA for any infringements of patents or other rights of the third parties which may result from its use. No license is granted by implication or otherwise under any patents or other rights of TOSHIBA or the third parties.
- Please contact your sales representative for product-by-product details in this document regarding RoHS compatibility. Please use these products in this document in compliance with all applicable laws and regulations that regulate the inclusion or use of controlled substances. Toshiba assumes no liability for damage or losses occurring as a result of noncompliance with applicable laws and regulations.