



JEWEL HILL ELECTRONIC CO.,LTD.

**SPECIFICATIONS FOR
LCD MODULE**

Module No. GB240128D

Office Address: Rm. 518,5/F., 101 Shangbu Industrial District,
HuaqiangNorthRoad, Shenzhen, China

TEL : (86)-755-83362489 83617492

FAX: (86)-755-83286396 83365871

E-mail: sales@jhlcd.com

jhlcd@21cn.com

Website: www.jhlcd.com

TABLE OF CONTENTS

LCM NUMBER SYSTEM	2
1. GENERAL DESCRIPTION	3
2. FEATURES.....	3
3. MECHANICAL SPECIFICATION	3
4. MECHANICAL DIMENSION	4
5. MAXIMUM RATINGS	5
6. ELECTRICAL CHARACTERISTICS	5
7. MODULE FUNCTION DESCRIPTION	6
8. ELECTRO-OPTICAL CHARACTERISTICS	15
9. RELIABILITY.....	19
10. PRECAUTIONS FOR USING LCD MODULES	20
11. USING LCD MODULES.....	22
12. REVISION HISTORY	24
SAMPLE APPROVED REPORT	25

LCM Number System

GB 240128 D S Y E W N D A - V00

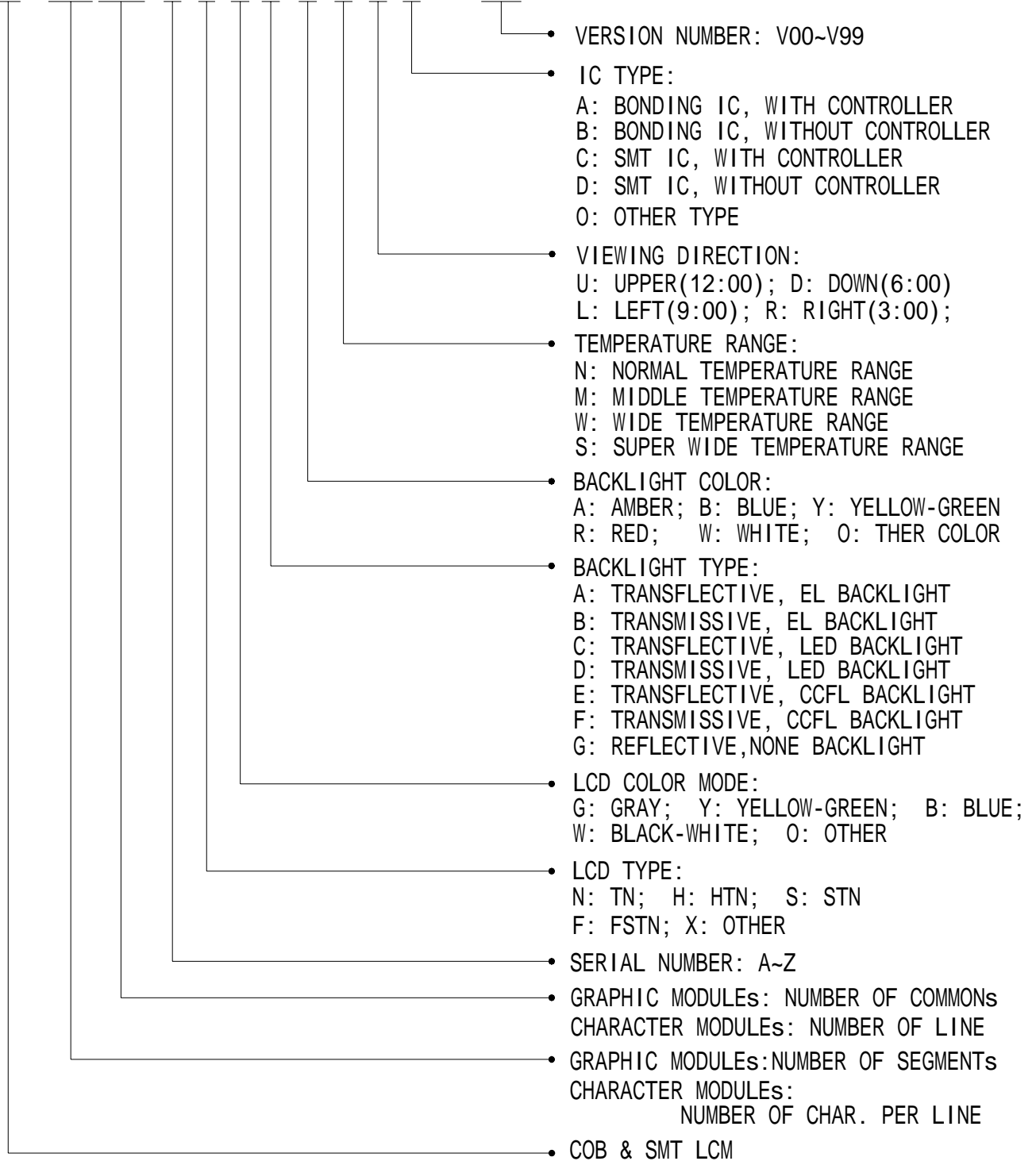

1. GENERAL DESCRIPTION

The GB240128D is a 240 x 128 Dots Graphics LCD module. It has a STN panel composed of 240segments and 128 commons. The LCM can be easily accessed by micro-controller via parallel interface.

2. FEATURES

Display Mode	Transflective and positive
	STN(Y-G) module
Display Format	Graphic 240 x 128 dots
Input Data	Serial data input from MPU
Multiplexing Ratio	1/128 Duty
Bias	1/13 Bias
Viewing Direction	6 O'clock
Backlight	CCFL (White)

3. MECHANICAL SPECIFICATION

Item	Specifications	Unit
Dimensional outline	144.0 x 104.0 x 13.5(max)	mm
Resolution	240segs x 128coms	dots
Active area	107.95(W) x 57.55(H)	mm
Dots pitch	0.45 (W)×0.45(H)	mm
Dots size	0.4(W)×0.4 (H)	mm

4. MECHANICAL DIMENSION

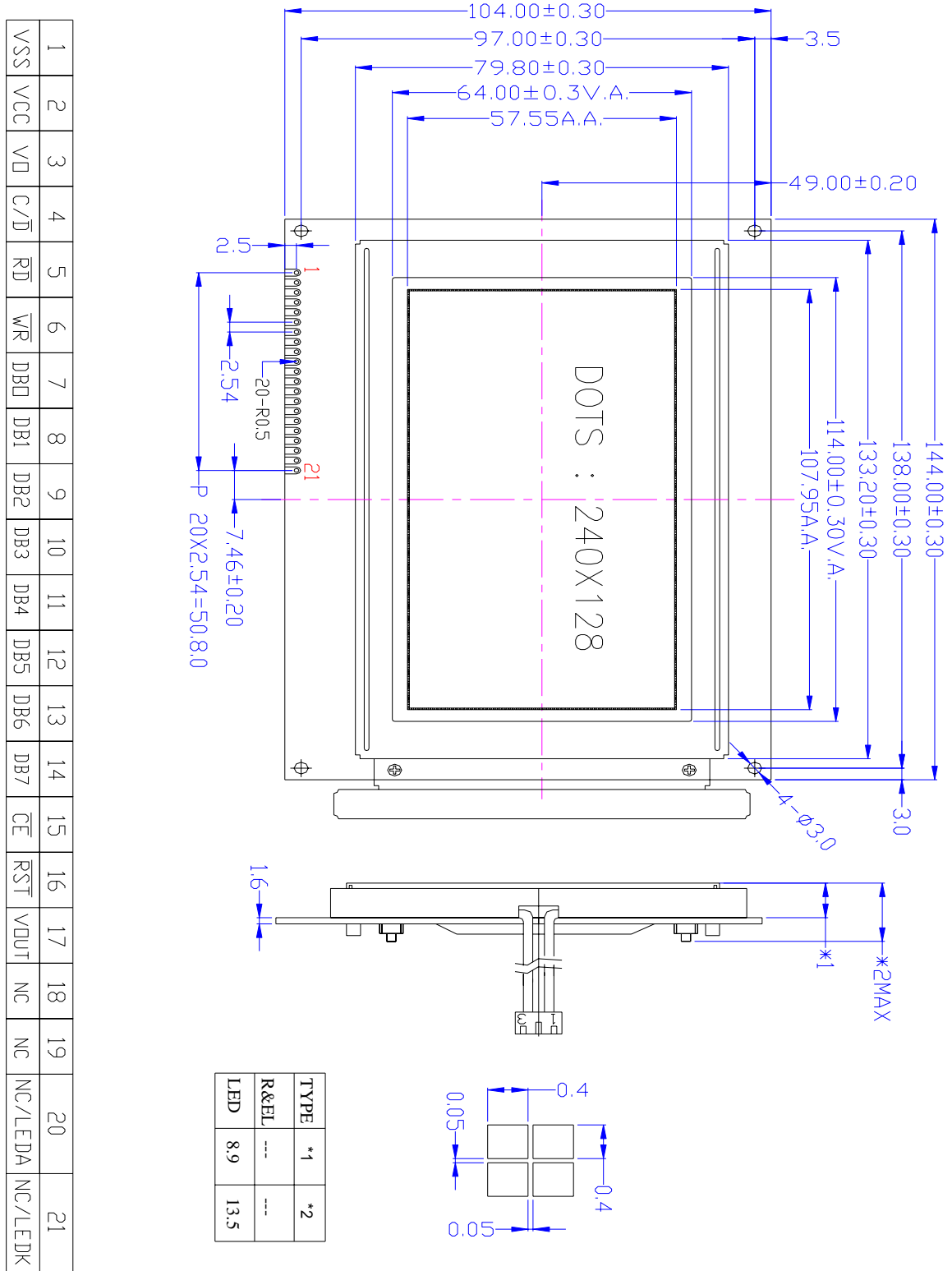

5. MAXIMUM RATINGS

Item	Symbol	Min	Max	Unit
Supply voltage	$V_{DD} - V_{SS}$	-0.3	6.5	V
	V_{LCD}	-0.3	24.0	V
Input Voltage	V_{IN}	-0.3	$V_{DD}+0.3$	V
Operating temperature	T_{OPR}	-10	+60	°C
Storage temperature	T_{STR}	-20	+70	°C
Humidity	---	---	90	%RH

6. ELECTRICAL CHARACTERISTICS

Item		Symbol	Condition	Min.	Typ.	Max.	Unit
Supply Voltage	Logic	V_{DD}	---	---	3.3/5.0	---	V
Input Voltage	H level	V_{IH}	---	$0.8V_{DD}$	---	V_{DD}	V
	L level	V_{IL}		V_{SS}	---	$0.2V_{DD}$	
Current Consumption (LCD DRIVER)		I_{DD}	$V_{DD}=5.0V$; $V_{LCD}=19.5V$; $T_{amb}=25^{\circ}C$;	---	---	25.0	mA
LCD Driving Voltage		V_{LCD}	Bias=1/13 $V_{LCD}=V_{DD}-V_0$	19.2	19.5	19.8	V

7. MODULE FUNCTION DESCRIPTION

7.1. PIN DESCRIPTION

Pin No.	Symbol	Description
1	VSS	Power supply for Ground (0V)
2	VCC	Power supply for positive (+5V)
3	VO	LCD driver voltage regulation pin
4	C/D	H: Data; L: Instruction
5	/RD	Read Enable signed, "L": Read
6	/WR	Write selection signal, "L": Write
7	DB0	8-bit bi-directional data bus
8	DB1	
9	DB2	
10	DB3	
11	DB4	
12	DB5	
13	DB6	
14	DB7	
15	/CE	Chip Enable Signal
16	/RST	Reset signal
17	VOUT	Power supply voltage for LCD driving
18	NC	No Connect
19	NC	No Connect
20	NC/LEDA	No Connect for CCFL B\L or Supply voltage for LED Positive
21	NC/LEDK	No Connect for CCFL B\L or Supply voltage for LED negative

7.2 TIMING CHARACTERISTICS

8822 搭配驱动器(Driver)ST8016/NT7701 在 Segment 和 Common 模式下的时序特性波形图，及参数表。



图 A-1: Segment 模式的时序特性波形图

表 A-1: Segment 操作的 Timing 参数

Parameter	Symbol	Conditions	Min.	Typ.	Max.	Unit	Note
Shift Clock Period	t_{WCK}	$t_R, t_F \cong 11\text{NS}$	125			ns	1
Shift Clock "H" Pulse Width	t_{WCKH}		51			ns	
Shift Clock "L" Pulse Width	t_{WCKL}		51			ns	
Data Setup Time	t_{DS}		30			ns	
Data Hold Time	t_{DH}		40			ns	
Latch Pulse "H" Pulse Width	t_{WLPH}		51			ns	
Shift Clock Rise to Latch Pulse Rise Time	t_{LD}		0			ns	
Shift Clock Fall to Latch Pulse Fall Time	t_{SL}		21			ns	
Latch Pulse Rise to Shift Clock Rise Time	t_{LS}		51			ns	
Latch Pulse Fall to Shift Clock Fall Time	t_{LH}		51			ns	
Enable Setup Time	t_S		36			ns	
Input Signal Rise Time	t_R				50	ns	2
Input Signal Fall Time	t_F				50	ns	2
DISPOFF Removal Time	t_{SD}		100			ns	

DISPOFF "L" Pulse Width	t_{WDL}		1.2		ns	
Output Delay Time(1)	t_D	CL=15pF			78	ns
Output Delay Time(2)	t_{PD1}, t_{PD2}	CL=15pF			1.2	us
Output Delay Time(3)	t_{PD3}	CL=15pF			1.2	us

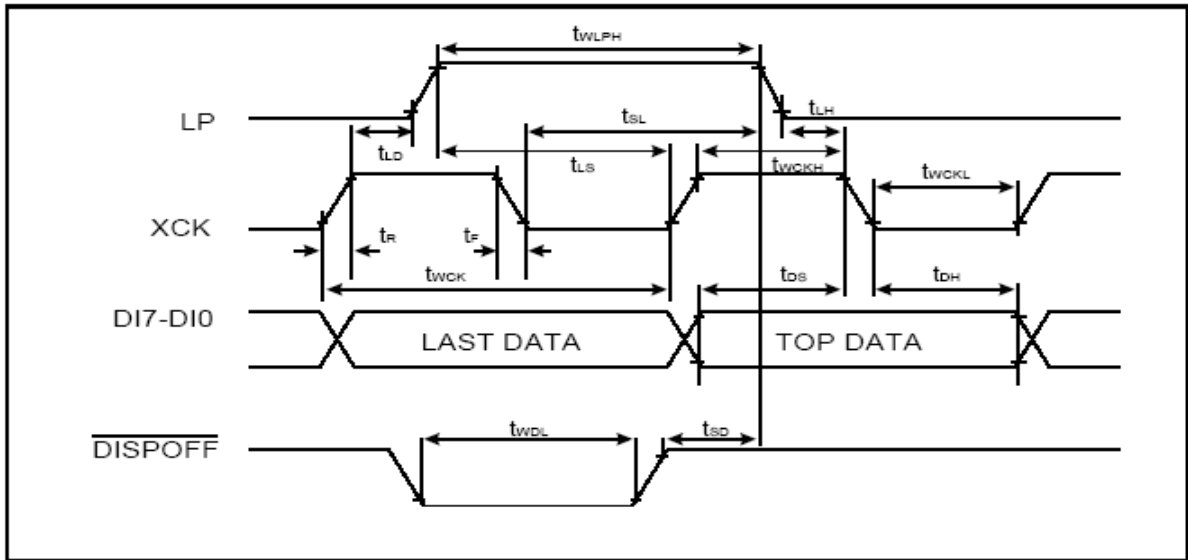
Note:

1. Takes the cascade connection into consideration.
2. $(t_{WCK} - t_{WCKH} - t_{WCKL})/2$ is maximum in the case of high-speed operation.

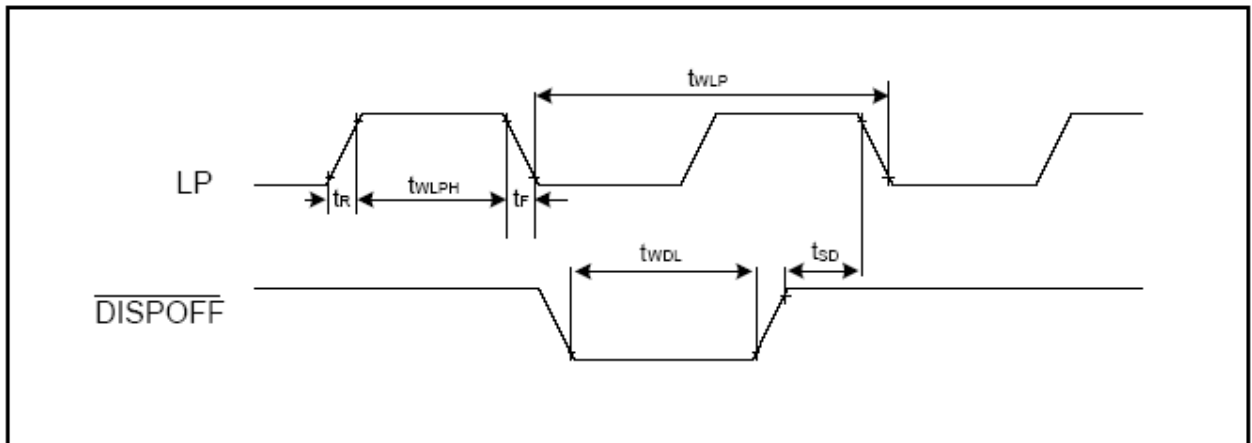
图 A-2: Common 模式的时序特性波形图
表 A-2: Common 操作的 Timing 参数

Parameter	Symbol	Conditions	Min.	Typ.	Max.	Unit	Note
Shift Clock Period	t_{WLP}	$t_R, t_F \leq 20ns$	125			ns	1
Shift Clock "H" Pulse Width	t_{WLPH}	VDD=5	51			ns	
Input Signal Rise Time	t_R				50	ns	2
Input Signal Fall Time	t_F				50	ns	2
DISPOFF Removal Time	t_{SD}		100			ns	
DISPOFF "L" Pulse Width	t_{WDL}		1.2			ns	
Output Delay Time(1)	t_D	CL=10pF			78	ns	
Output Delay Time(2)	t_{PD1}, t_{PD2}	CL=10pF			1.2	us	
Output Delay Time(3)	t_{PD3}	CL=10pF			1.2	us	

微控制器(MPU)的接口

RA8803/8822 文字/图形 LCD 控制器与一般的 LCD 控制器相类似，都有支持 8080 和 6800 两大系列属性的 MPU 接口。使用者可以透过 SYS_MI 这根脚位去选择 RA8803/8822 的 MPU 接口是 8080 或者是 6800 的兼容系统，如果 SYS_MI 外接一 Pull Low 电阻，则 RA8803/8822 的 MPU 将定义成与 8080 兼容的接口。反之，如果 SYS_MI 外接一 Pull High 电阻，则 RA8803/8822 的 MPU 接口将定义成与 6800 兼容的接口。

2-1 8080 系列的 MPU 接口

图 2-1 是 RA8803/8822 与 8080 兼容系列的 MPU 接口示意图，此时 RA8803/8822 将只接受与 8080 系列兼容的 MPU 所传送出来的控制信号。



图 2-1: 8080 (4/8-bit) MPU 与 RA8803/8822 的界面图

图 2-2 是 8080 系列 MPU 与 RA8803/8822 间的系统时序图，在 RA8803/8822 的定义中，RS 为“L”时是表示对缓存器下命令，也就是对 RA8803/8822 的缓存器进行读写的动作(Register Access Cycle)，而 RS 为“H”时是表示对 Display RAM 进行 Data 读写的动作(Data Access Cycle)。不论是 8080 或 6800，“RS” Pin 通常接到 MPU 的 Address Pin “A0”，8080 系列 MPU 与 6800 最大的不同是 Read、Write 的控制信号是分开的，RD 为 Low 时是进行读取动作，WR 为 Low 时是进行写入动作，至于读写的目的地则由 RS 决定。

下面图 2-2 表示如果是对缓存器进行读取动作，MPU 必须透过数据总线先送出缓存器的地址，然后才能在数据总线上读取缓存器的数据，如果是对缓存器进行写入动作，MPU 必须透过数据总线先送出缓存器的地址，然后再送出要写入的数据。当 8088 MPU 对 RA8803/8822 Display RAM 进行数据的读取动作，MPU 能直接在数据总线上读取 Display RAM 的数据，如果 8088 MPU 对 Display RAM 进行数据的

写入动作，MPU 则直接在数据总线上送出要写入的数据。

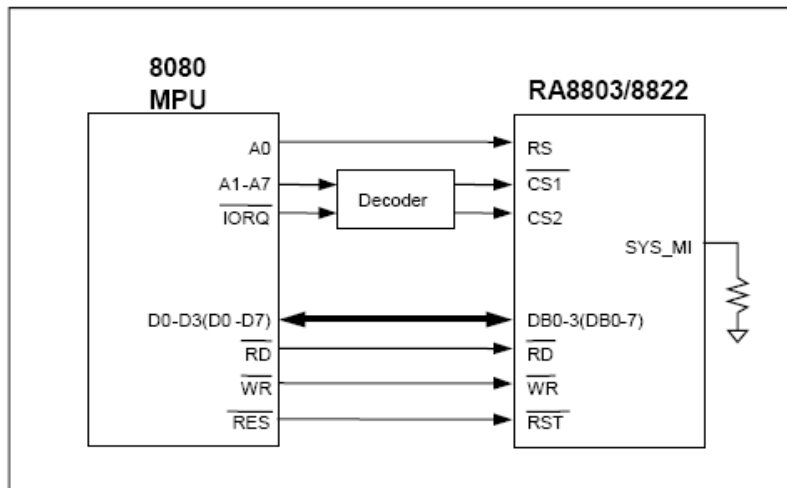

图 2-2: 8-Bit 8080 MPU 对 RA8803/8822 缓存器/Data 进行读取/写入动作

表 2-1

Signal	Symbol	Parameter	Rating		Unit	Condition
			Min	Max		
RS, CS1#	t_{AH8}	Address hold time	10	--	ns	System Clock: 8MHz Voltage: 3.3V
	t_{AW8}	Address setup time	63	--	ns	
WR#, RD#	t_{CYC}	System cycle time	800	--	ns	
	t_{CC}	Strobe pulse width	400	--	ns	
DB0 to DB7	t_{DS8}	Data setup time	63	--	ns	
	t_{DH8}	Data hold time	10	--	ns	
	t_{ACC8}	RD access time	--	330	ns	
	t_{OH8}	Output disable time	10	--	ns	

2-2 6800 系列的 MPU 接口

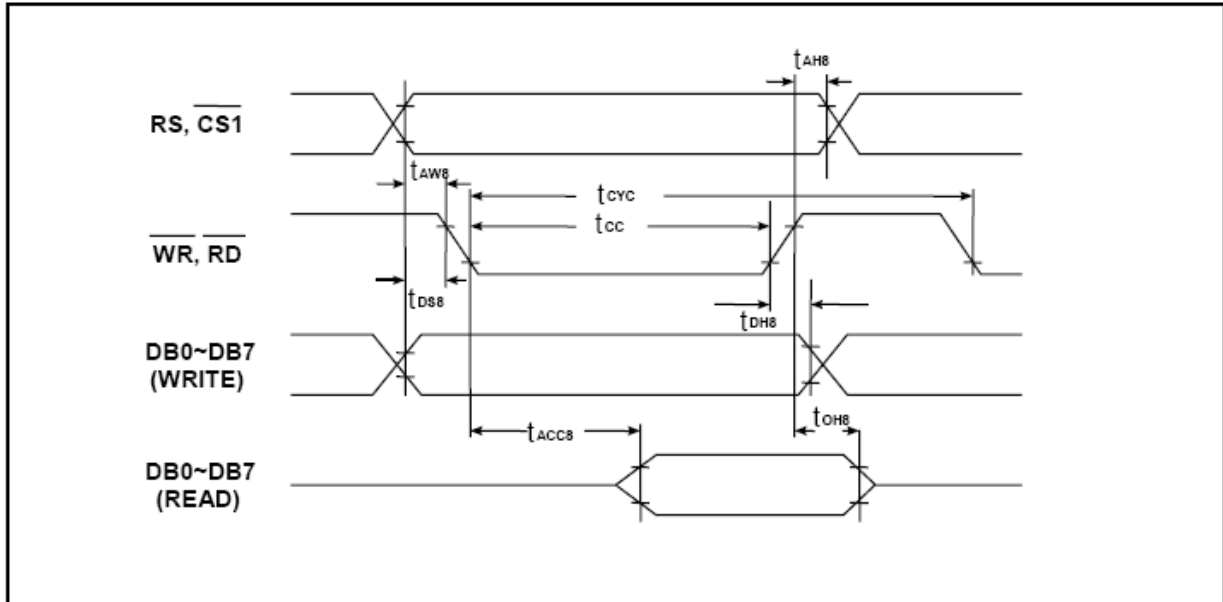
图 2-3 是 RA8803/8822 与 6800 兼容系列的 MPU 接口示意图，此时 RA8803/8822 将只接受 6800 系列兼容的 MPU 所传送出来的控制时序。6800 系列 MPU Read、Write 的控制信号是同一根 Pin，R/W# 为 High 时是进行读取动作，R/W# 为 Low 时是进行写入动作，而 EN 则是确定读写的动作是否有效 (Enable)，至于读写的目的地仍由 RS 决定。



图 2-3: 6800 (8-bit) MPU 与 RA8803/8822 的界面图

RA8803/8822 无法同时接受 6800 及 8080 的控制信号，因此在 MPU 的接口上，某些脚位上会因为使用者选择不同的 MPU 而有不同的定义，例如脚位 RD#(EN)，当使用者选择的 MPU 接口为 8080 时是定义成 RD#，而选择 6800 MPU 时是定义为 EN。而脚位 WR#(R/W#)，当使用者选择的 MPU 接口为 8080 时是定义成 WR#，而选择 6800 MPU 时是定义为 R/W#，对于 MPU 接口的脚位定义，使用者可以参考 RA8803/8822 规格书第 4-1 节的说明。

下面图 2-4 表示如果是 6800 MPU 对 RA8803/8822 缓存器进行读取动作，MPU 必须透过数据总线先送出缓存器的地址，然后才能在数据总线上读取缓存器的数据，如果是对缓存器进行写入动作，MPU 必须透过数据总线先送出缓存器的地址，然后再送出要写入的数据。当 6800 对 RA8803/8822 Display RAM 进行数据的读取动作，MPU 能直接在数据总线上读取 Display RAM 的数据，如果 6800 MPU 对 Display RAM 进行数据的写入动作，则 MPU 直接在数据总线上送出要写入的数据。

对于 6800 MPU 的接口，RA8803/8822 只提供 8Bit 的传输功能，而对于 8080 MPU 的接口，RA8803/8822 提供 4Bit 或 8Bit 的传输功能。

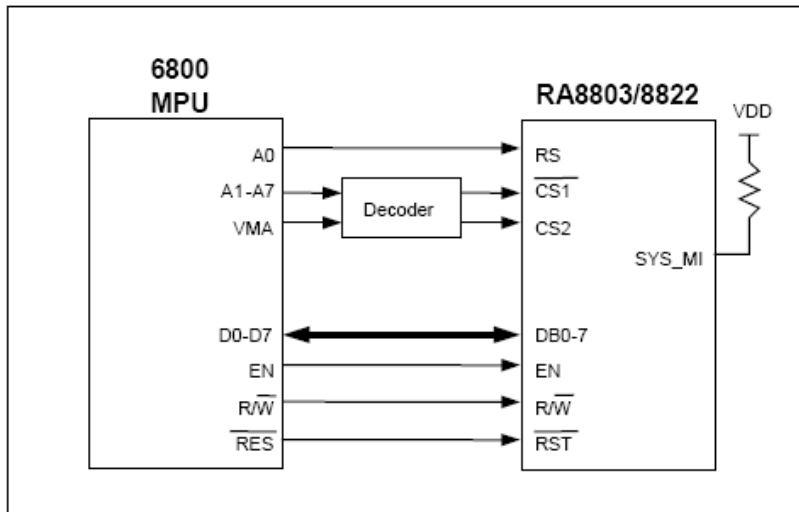

图 2-4: 8-bit 6800 MPU 对 RA8803/8822 缓存器/Data 进行读取/写入动作

表 2-2

Signal	Symbol	Parameter	Rating		Unit	Condition
			Min	Max		
A0, R/W#, CS1#	t_{AHs}	Address hold time	10	--	ns	System Clock: 8MHz Voltage: 3.3V
	t_{AWs}	Address setup time	63	--	ns	
	t_{CYCs}	System cycle time	800	--	ns	
DB0 to DB7	t_{DSs}	Data setup time	63	--	ns	
	t_{DHs}	Data hold time	10	--	ns	
	t_{ACCs}	Access time	--	330	ns	
	t_{OHs}	Output disable time	10	--	ns	
EN	t_{EW}	Enable pulse width	400	--	ns	

2-3 4Bit/8Bit 的 MPU 界面

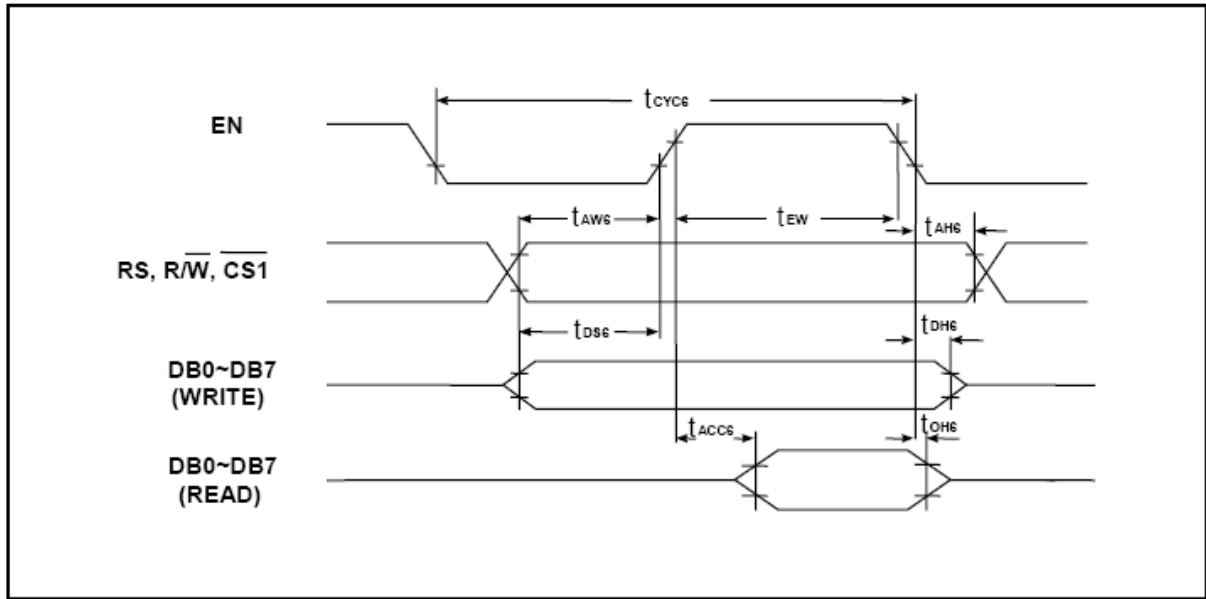
对于 8080 MPU 的接口, RA8803/8822 提供 4Bit 或 8Bit 的传输功能。使用者可以透过 SYS_DB 这根脚位去选择 MPU 的数据总线(Data Bus)接口, 如果 SYS_DB 外接一 Pull Low 电阻, 则 RA8803/8822 的 MPU 数据总线接口将定义成 4-Bit。反之, 如果 SYS_DB 外接一 Pull High 电阻, 则 RA8803/8822 的 MPU 数据总线接口将定为 8-Bit。因为 RA8803/8822 内部的缓存器大多是 8-Bit 的架构, 因此如果使用 4-Bit 的数据总线接口, MPU 将会花较多的周期(Cycle)去存取 RA8803/8822 内部的缓存器。

当选择 4-bit MPU 作传输模式时，RA8803/8822 的 MPU 接口只有用到数据总线的 D3~D0，而没有用到的 D7~D4 则不必理会(当成 NC Pin)，同时每一个八位的指令或数据将被分为两个 Nibble(4-Bit)依序透过数据总线的 D3~D0 进行传送，第一次先透过总线(DB3~DB0)传送数据的较高位 Bit[7..4]，第二次再透过总线(D3~D0)传送数据的较低位 Bit[3..0]，使用者可以参考 2-4 节中的例题 5~8。

不过对于 6800 MPU 的接口，RA8803/8822 只提供 8Bit 的传输功能，且由于大部份使用者使用 8051 系统产品做系统开发，也比较熟悉此系列的 MPU，因此建议使用 8080 的 MPU 接口。

7.3 APPLICATION OF LCM

■Circuit Block Diagram

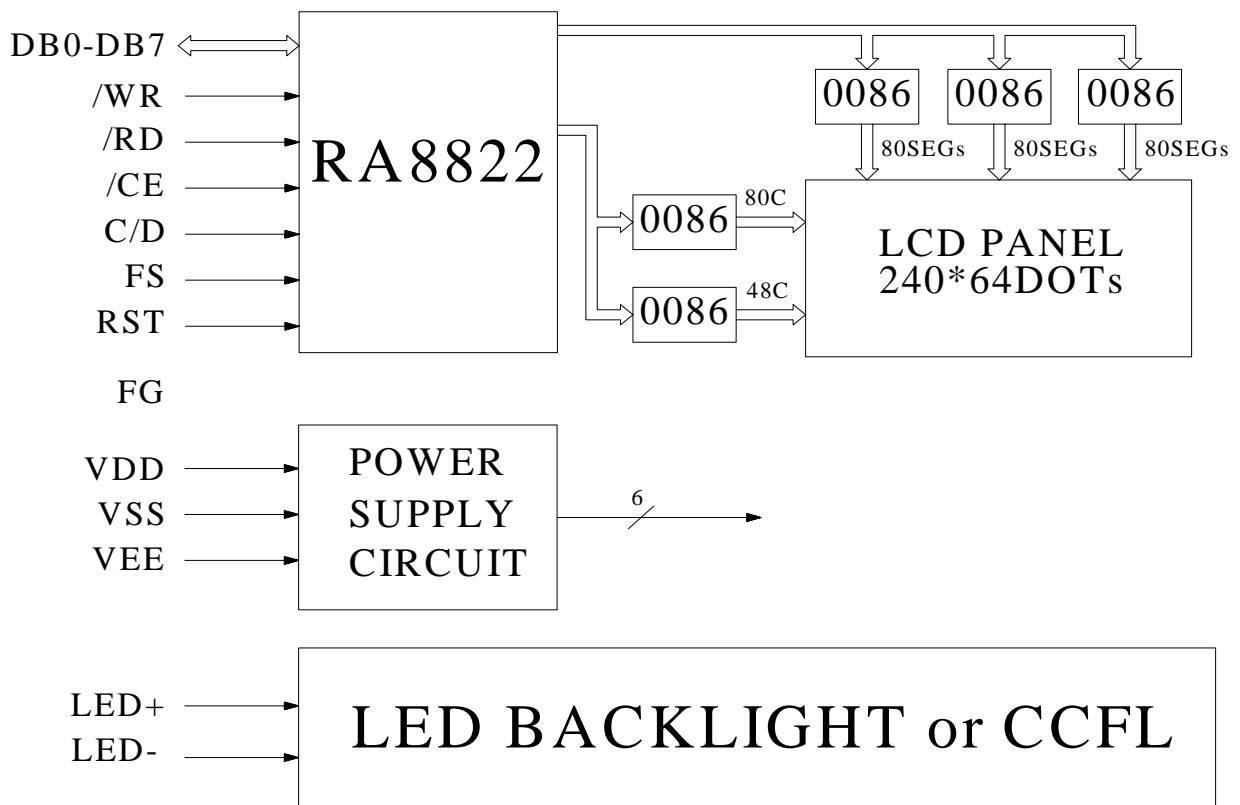

7.4 TABLE OF COMMAND

See the RA8022 Specification.

8. ELECTRO-OPTICAL CHARACTERISTICS

Item	Symbol	Condition	Temp	Min	Typ.	Max	Units	Note
LCD driving voltage	V _{LCD}	$\theta = \phi = 0$	0°C	---	19.8	---	V	NOTE1
			25°C	18.8	19.5	20.2		
			50°C	---	19.2	---		
Response Time	Rise Time (Tr)	$\theta = \phi = 0$	0°C	---	---	--	msec	NOTE2
	Decay Time (Tf)			---	---	---		
	Rise Time (Tr)		25°C	---	225	340		
	Decay Time (Tf)			---	240	360		
	Rise Time (Tr)		50°C	---	---	--		
	Decay Time (Tf)			---	---	--		
Contrast Ratio	Cr	$\theta = \phi = 0$	25°C	5	10	---	---	NOTE4

Viewing Angle Range	$\theta (\phi = 0^\circ)$ (6'')	$\phi = 90^\circ$ (3'')	$\phi = 180^\circ$ (12'')	$\phi = 270^\circ$ (9'')	備註
$\theta (25^\circ\text{C})$ CR≥2	50	35	25	40	Deg NOTE3

● For panel only

• **Electro-Optical Characteristics Measuring Equipment(DMS501)**

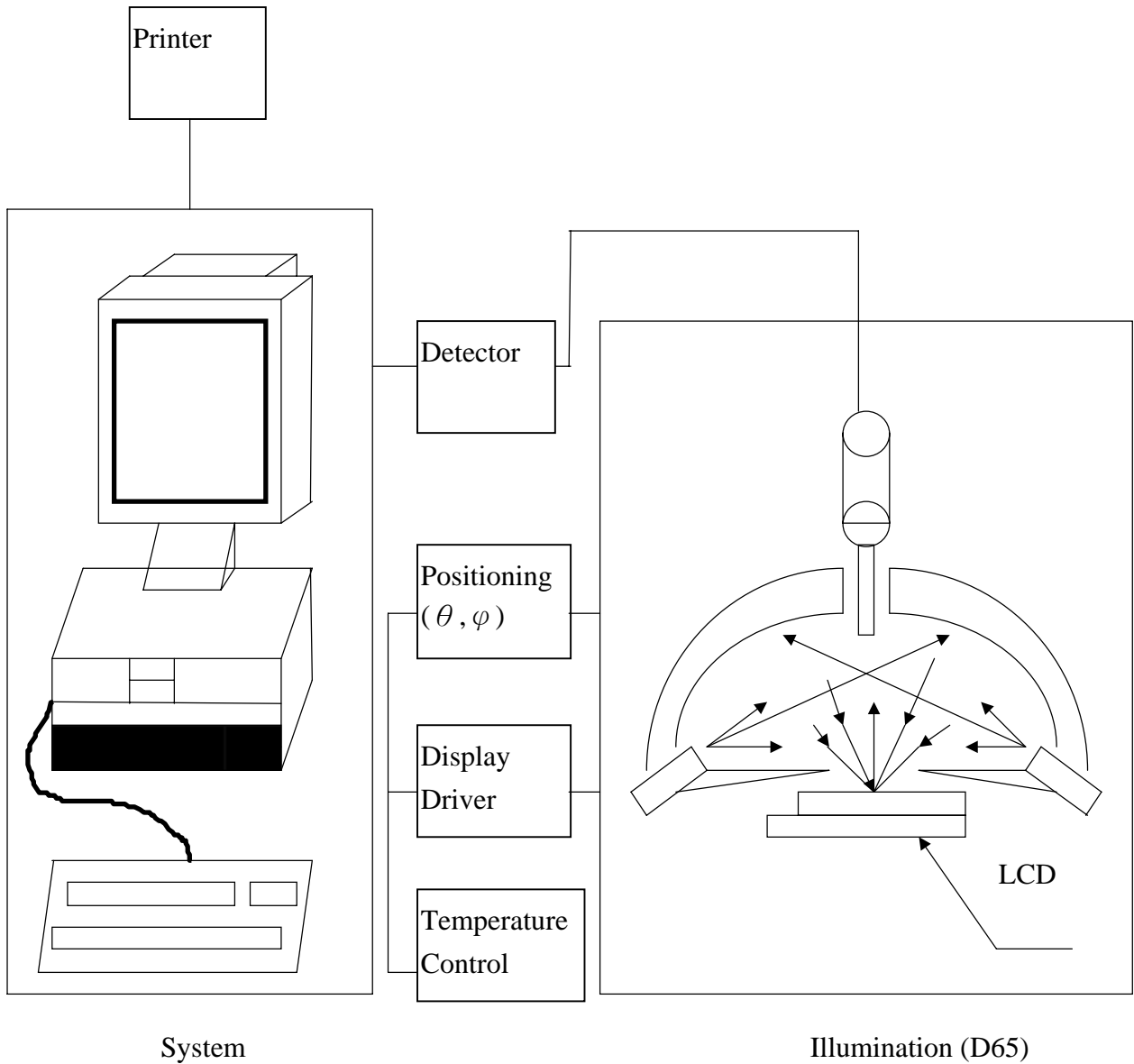

• **Note 1. Definition of Driving Voltage(V_{lcd}) :**



• **Note 2. Definition of Optical Response Time :**



• **Note 3. Definition of Viewing Angle θ and ϕ :**



• **Note 4. Definition of Contrast ratio(CR) :**

$$CR = \frac{\text{Brightness of Non-selected Segment (B2)}}{\text{Brightness of Selected Segment (B1)}}$$



9. RELIABILITY

9.1. MTBF

The LCD module shall be designed to meet a minimum MTBF value of 50000 hours with normal. (25°C in the room without sunlight)

9.2. TESTS

NO.	ITEM	CONDITION	CRITERION
1	High Temperature Operating	50°C 120Hrs	<ul style="list-style-type: none"> ◦ No Defect Of Operational Function In Room Temperature Are Allowable. ◦ IDD of LCM in Pre-and post-test should follow specification
2	Low Temperature Operating	0°C 120Hrs	
3	High Temperature/ Humidity Non-Operating	50°C ,90%RH ,120 Hrs	
4	High Temperature Non-Operating	60°C 120Hrs	
5	Low Temperature Non-Operating	-10°C 120Hrs	
6	Temperature Cycling Non-Operating	0°C (30Min)↔ 50°C (30Min) 10 CYCLES	

Notes: Judgments should be made after exposure in room temperature for two hours.

10. PRECAUTIONS FOR USING LCD MODULES

10.1. HANDLING PRECAUTIONS

- (1) The display panel is made of glass. Do not subject it to a mechanical shock or impact by dropping it.
- (2) If the display panel is damaged and the liquid crystal substance leaks out, be sure not to get any in your mouth. If the substance contacts your skin or clothes, wash it off using soap and water.
- (3) Do not apply excessive force to the display surface or the adjoining areas since this may cause the color tone to vary.
- (4) The polarizer covering the display surface of the LCD module is soft and easily scratched. Handle this polarizer carefully.
- (5) If the display surface becomes contaminated, breathe on the surface and gently wipe it with a soft dry cloth. If it is heavily contaminated, moisten a cloth with one of the following solvents:
 - Isopropyl alcohol
 - Ethyl alcohol
- (6) Solvents other than those above mentioned may damage the polarizer.
Especially, do not use the following:
 - Water
 - Ketone
 - Aromatic solvents
- (7) Extra care to minimize corrosion of the electrode. Water droplets, moisture condensation or a current flow in a high-humidity environment accelerates corrosion of the electrode.
- (8) Install the LCD Module by using the mounting holes. When mounting the LCD Module, make sure it is free of twisting, warping and distortion. In particular, do not forcibly pull or bend the I/O cable or the backlight cable.
- (9) Do not attempt to disassemble or process the LCD Module.
- (10) NC terminal should be open. Do not connect anything.
- (11) If the logic circuit power is off, do not apply the input signals.
- (12) To prevent destruction of the elements by static electricity, be careful to maintain an optimum work environment.
 - Be sure to ground the body when handling the LCD Module.
 - Tools required for assembling, such as soldering irons, must be properly grounded.
 - To reduce the amount of static electricity generated, do not conduct assembling and other work under dry conditions.

-The LCD Module is coated with a film to protect the display surface. Exercise care when peeling off this protective film since static electricity may be generated.

10.2. STORAGE CONDITIONS

When storing, avoid the LCD module to be exposed to direct sunlight of fluorescent lamps. For stability, to keep it away from high temperature and high humidity environment (The best condition is : $23\pm 5^{\circ}\text{C}$, $45\pm 20\% \text{RH}$). ESD protection is necessary for long-term storage also.

10.3. OTHERS

Liquid crystals solidify under low temperature (below the storage temperature range) leading to defective orientation or the generation of air bubbles (black or white). Air bubbles may also be generated if the module is subject to a low temperature.

If the LCD Module have been operating for a long time showing the same display patterns the display patterns may remain on the screen as ghost images and a slight contrast irregularity may also appear. A normal operating status can be recovered by suspending use for some time. It should be noted that this phenomenon does not adversely affect performance reliability.

To minimize the performance degradation of the LCD Module resulting from destruction caused by static electricity etc. exercise care to avoid holding the following sections when handling the modules.

- Exposed area of the printed circuit board.
- Terminal electrode sections.

11. Using LCD modules

11.1 LIQUID CRYSTAL DISPLAY MODULES

LCD is composed of glass and polarizer. Pay attention to the following items when handling.

- (1) Please keep the temperature within specified range for use and storage. Polarization degradation, bubble generation or polarizer peel-off may occur with high temperature and high humidity.
- (2) Do not touch, push or rub the exposed polarizers with anything harder than a HB pencil lead (glass, tweezers, etc).
- (3) N-hexane is recommended for cleaning the adhesives used to attach front/rear polarizers and reflectors made of organic substances, which will be damaged by chemicals such as acetone, toluene, toluene, ethanol and isopropyl alcohol.
- (4) When the display surface becomes dusty, wipe gently with absorbent cotton or other soft material like chamois soaked in petroleum ether. Do not scrub hard to avoid damaging the display surface.
- (5) Wipe off saliva or water drops immediately, contact with water over a long period of time may cause deformation or color fading.
- (6) Avoid contacting oil and fats.
- (7) Condensation on the surface and contact with terminals due to cold will damage, stain or polarizers. After products are tested at low temperature they must be warmed up in a container before coming is contacting with room temperature air.
- (8) Do not put or attach anything on the display area to avoid leaving marks on.
- (9) Do not touch the display with bare hands. This will stain the display area and degrade insulation between terminals (some cosmetics are determinate to the polarizers).
- (10) As glass is fragile, it tends to become or chipped during handling especially on the edges. Please avoid dropping or jarring.

11.2 INSTALLING LCD MODULE

Attend to the following items when installing the LCM.

- (1) Cover the surface with a transparent protective plate to protect the polarizer and LC cell.
- (2) When assembling the LCM into other equipment, the spacer to the bit between the LCM and the fitting plate should have enough height to avoid causing stress to the module surface, refer to the individual specifications for measurements. The measurement tolerance should be ± 0.1 mm.

11.3 ELECTRO-STATIC DISCHARGE CONTROL

Since this module uses a CMOS LSI, the same careful attention should be paid for electrostatic discharge as for an ordinary CMOS IC.

- (1) Make certain that you are grounded when handling LCM.
- (2) Before removing LCM from its packing case or incorporating it into a set, be sure the module and your body have the same electric potential.
- (3) When soldering the terminal of LCM, make certain the AC power source for the soldering iron does not leak.
- (4) When using an electric screwdriver to attach LCM, the screwdriver should be of ground potentiality to minimize as much as possible any transmission of electromagnetic waves produced sparks coming from the commutator of the motor.
- (5) As far as possible, make the electric potential of your work clothes and that of the workbenches to the ground potential.
- (6) To reduce the generation of electro-static discharge, be careful that the air in the work is not too dried. A relative humidity of 50%-60% is recommended.

11.4 PRECAUTIONS FOR OPERATION

- (1) Viewing angle varies with the change of liquid crystal driving voltage (V_o). Adjust V_o to show the best contrast.
- (2) Driving the LCD in the voltage above the limit will shorten its lifetime.
- (3) Response time is greatly delayed at temperature below the operating temperature range. However, this does not mean the LCD will be out of the order. It will recover when it returns to the specified temperature range.
- (4) If the display area is pushed hard during operation, the display will become abnormal. However, it will return to normal if it is turned off and then on.
- (5) Condensation on terminals can cause an electrochemical reaction disrupting the terminal circuit. Therefore, this product must be used and stored within the specified condition of $23\pm 5^{\circ}\text{C}$, $45\pm 20\% \text{RH}$.
- (6) When turning the power on, input each signal after the positive/negative voltage becomes stable.

11.5 SAFETY

- (1) It is recommended to crush damaged or unnecessary LCDs into pieces and wash them off with solvents such as acetone and ethanol, which should later be burned.
- (2) If any liquid leaks out of a damaged glass cell and comes in contact with the hands, wash off thoroughly with soap and water.

12. REVISION HISTORY

Version	Revise record	Date
1.0	Original version	06-02-21
2.0	Change contact mode	06-08-04

SAMPLE APPROVED REPORT (样品确认单)

SAMPLE MODEL NO. (样品型号)	GB240128D
SAMPLE SERIES NUMBER NO. (样品序号)	
SAMPLE QUANTITY (样品数量)	
COLOR/TYPE (底色/类型)	STN/Y-G
VIEWING DIRECTION (视角)	6:00
DRIVING METHOD (驱动参数)	1/128Duty, 1/13Bias
IC DRIVING VOLTAGE (IC 驱动电压)	3.3/5.0V
LCD VOP (LCD 操作电压)	19.5V
OPERATING TEMP. (操作温度)	0~50
STORAGE TEMP. (储存温度)	-10~60
POLARIZER----FRONT (首偏光片)	TRANSMISSION
POLARIZER----BACK (后偏光片)	TRANSFLECTIVE
CONTROLLER/DRIVER IC(控制/驱动 IC)	RA8822/S6B0086
BACKLIGHT COLOR/TYPE (背光源类型/颜色)	CCFL/WHITE
DRAWING REV/NO./QUANTITY (图纸版本/数量)	
SPECIFICATION (规格书 份数)	1
REMARKS : (备注)	
WRIT BY : _____ DATE : _____ APROV BY : _____ DATE : _____	
CUSTOMER'S APPROVAL (客户确认) :	
1) FUNCTION (功能) : <input type="checkbox"/> OK <input type="checkbox"/> N.G.	
2) DRIVER CONDITION (驱动条件) : <input type="checkbox"/> OK <input type="checkbox"/> N.G.	
3) DISPLAY MODE (显示模式) : <input type="checkbox"/> OK <input type="checkbox"/> N.G.	
4) VIEWING ANGLE (视角) : <input type="checkbox"/> OK <input type="checkbox"/> N.G.	
5) BACKLIGHT (背光源) : <input type="checkbox"/> OK <input type="checkbox"/> N.G.	
6) DISPLAYING PATTERN (显示效果) : <input type="checkbox"/> OK <input type="checkbox"/> N.G.	
CUSTOMER'S CONCLUSIONS (客户意见) : _____	

CUSTOMER'S SIGNATURE (客户签名) : _____ DATE (日期) : _____	