

Features and Benefits

- ❑ Suited cost optimized sensors: gain and offset correction by programmable coefficients
- ❑ Higher order temperature compensation provided for both gain and offset
- ❑ External or internal temperature sensor for compensation of temperature errors
- ❑ Over-voltage protection
- ❑ Fault detection and clamping levels
- ❑ Ratio-metric output: 0 to 5V
- ❑ Single Pin Digital Programming
- ❑ Fully analog signal path

Applications Examples

- ❑ Pressure transducers, strain gauges, accelerometers, position sensors, etc.
- ❑ Steering systems (e.g. torque sensors)
- ❑ Safety restraints systems (e.g. seat occupant detection)
- ❑ Braking systems (e.g. ABS, force)
- ❑ Comfort systems (e.g. air conditioning)
- ❑ Engine management (e.g. injection)
- ❑ Any bridge type sensor

Ordering Information

Part No.
MLX90320LFR

Temperature Code
L (-40°C to 150°C)

Package Code
FR (SSOP 209 mil)

1 Functional diagram

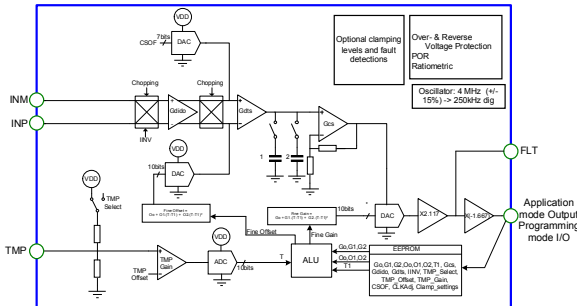

2 General description

The MLX90320 covers the most typical resistive type of Wheatstone bridge applications for use in an automotive environment. It is a monolithic silicon analog integrated sensor interface that converts small changes in resistors, configured in a full Wheatstone bridge on a sensing element, to large output voltage variations.

The signal conditioning includes gain adjustment, offset control and second order temperature compensation in order to accommodate variations of the different resistive sensing elements. Compensation values are stored in EEPROM and can be reprogrammed with an interface circuit and a provided software. The MLX90320 is programmed with a single wire serial interface through the output pin.

The user can specify on chip clamping levels thus creating fault detection bands. By intercepting various fault modes the MLX90320 is able to inform about the reliability of its analog output signal.

Table of Contents

1 Functional diagram	1
2 General description.....	1
3 Maximum ratings.....	3
4 Pad definitions and descriptions	4
5 MLX90320 General Specifications.....	5
6 Detailed Description.....	9
6.1 EEPROM	10
6.2 The programmable clock.	10
6.3 The temperature chain.....	11
6.4 The sensor signal chain.	12
6.4.1 The Gain calibration of the sensor signal chain.	13
6.4.2 The Offset calibration of the sensor signal chain.	14
6.4.3 The output clamping levels	15
6.4.4 The Faults detection	16
6.5 Programming the MLX90320 through the output pin	18
6.5.1 Overview.....	18
6.5.2 Communication Request.....	18
6.5.3 Bit format	19
6.5.4 Commands	20
7 Unique Features	22
8 Typical applications circuits	23
8.1 Ratio-metric mode with use of external temperature sensor.....	23
8.2 Ratio-metric mode without use of external temperature sensor.....	24
8.3 Non Ratio-metric mode with use of external temperature sensor.	24
8.4 Non Ratio-metric mode without use of external temperature sensor.	25
9 EEPROM Contents.....	25
10 Reliability Information.....	29
11 ESD Precautions.....	29
12 Package Information.....	30
13 Disclaimer	32

3 Maximum ratings

Parameter.	Min	Max	Units	Comments
Supply Voltage, V_{DD}	-14	16	V	No latch-up or damage. Rise time(10 to 90%) $t_r \geq 1\mu s$.
Supply Voltage, $V_{DD} - V_{SS}$	4.5	5.5	V	Operating within specifications
Output current limit	-50	-9	mA	Short to V_{DD}
	9	50	mA	Short to Gnd
Operating Temperature Range, $T_{environment}$	-40	140	°C	
Storage Temperature Range	-50	150	°C	
Programming Temperature Range	-40	125	°C	
Package Thermal Resistance		130	°C/W	
ESD Sensitivity	2		kV	HBM. CDF - AEC - Q100-002
Latch-up withstand				CDF - AEC - Q100-004; $V_{DD} = 5.5V$

Table 1: Absolute maximum ratings

Exceeding the absolute maximum ratings may cause permanent damage. Exposure to absolute-maximum-rated conditions for extended periods may affect device reliability.

4 Pad definitions and descriptions

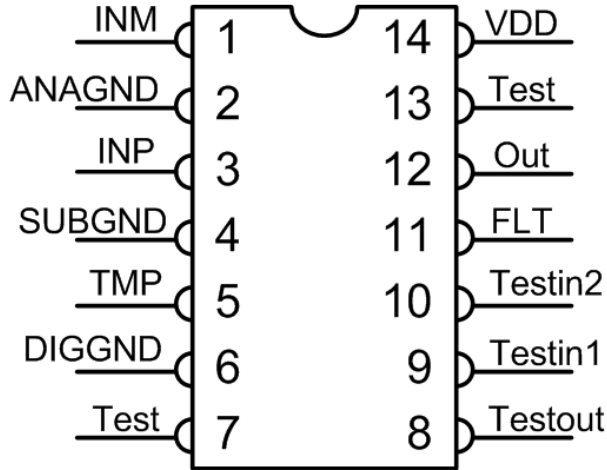

Package Pin Nr	Short Name	Dir	Type	Function / Description
1	INM	IN	Analog	Bridge Sensor Negative
2	ANAGND	gnd		Analog Ground
3	INP	IN	Analog	Bridge Sensor Positive
4	SUB	gnd		Substrate Ground
5	TMP	IN	Temp	External Temperature Sensor (Resistor to supply)
6	DIGGND	gnd		Digital Ground
7	Test	NC		On module to ground.
8	TESTOUT	OUT	Test	Test Output. On module to ground
9	TESTIN1	IN	Test	Test Input 1: CLKEXT, TEST (3 level)
10	TESTIN2	IN	Test	Test Input 2: DATAIN, SCAN (3 level)
11	FLT	OUT	Analog	Filter pin
12	OUT	BI	Analog	Analog output and communication pin
13	Test	NC		On module to ground
14	VDD	power	Supply	Supply

Table 2: Pin description MLX90320

5 MLX90320 General Specifications

DC Operating Parameters $T_A = -40^{\circ}\text{C}$ to 140°C , $V_{DD} = 5\text{V}$ (unless otherwise specified)

General Electrical Specifications						
Parameter.	Symbol	Comments	Min	Typ	Max	Units
Supply Voltage	VDD		4.5		5.5	V
Supply Current	IDD	No output load, $V_{DD}=5\text{V}\pm 10\%$			7	mA
Output capacitive load		$10\Omega < R_{\text{SERIES}} < 10\text{ k}\Omega$	0		300	nF
Output resistive load			2			k Ω
Output current capability			± 2.5			mA
Output short circuit current		$V_{DD}=5\text{V}\pm 10\%$			± 50	mA
Digital output current			± 2		± 5	mA
V_{DD} line inductance			0		22	μH

Clamping Levels Specifications						
Parameter.	Symbol	Comments	Min	Typ	Max	Units
Clamping output low 0	Clamp low min	See paragraph 6.4.3 for detailed explanation	3	4	5	$\%V_{DD}$
Clamping output low 1		7 other low clamping levels with a clamp level variation of $1.3\%V_{DD}$ for each		Clamp low min + $1.3\%V_{DD}$		$\%V_{DD}$
Clamping output low n		$n = [0..7]$		Clamp low min + $n \cdot 1.3\%V_{DD}$		$\%V_{DD}$
Clamping output high 0	Clamp high max	See paragraph 6.4.3 for detailed explanation	95	96	97	$\%V_{DD}$

Clamping output high1		7 other high clamping levels with a clamp level variation of 1.3%V _{DD} for each		Clamp high max - 1.3%V _{DD}		%V _{DD}
Clamping output high n		n = [0..7]		Clamp high max - n*1.3%V _{DD}		%V _{DD}

Diagnostic Limits Specifications						
Parameter.	Symbol	Comments	Min	Typ	Max	Units
Low diagnostic output			0		4	%V _{DD}
High diagnostic output			96			%V _{DD}

Signal path general Specifications						
Parameter.	Symbol	Comments	Min	Typ	Max	Units
Overall gain		See table 3 below for an overview	12.7		442	V/V
Coarse gain	G _{did0}	1bit programmable	3.25		13	V/V
	G _{dts}	1bit programmable	2		5	V/V
	G _{cs}	1bit programmable	1.24		1.9375	V/V
Fine gain	Fgain	10 bit programmable	0.448		0.99	V/V
Sensor output span that can be accommodated to achieve 4V output span		Without an optimal compensation of the sensitivity temperature drift (i.e. with the fine gain equal to one of the extreme range values)	1.8		63	mV/V _{supply}
Sensor output span that can be accommodated to achieve 4V output span		With an optimal compensation of the sensitivity temperature drift (i.e. with the fine gain equal to the middle range value)	2.5		40	mV/V _{supply}

Sensor offset that can be compensated		Depends on gain settings and desired output offset voltage. See Table 3 below for an overview.	0.4		97.2	mV/V _{supply}
Output Offset programmable			10		90	%V _{DD}
Output Offset resolution					0.1	%V _{DD}
Overall non linearity		Best fit value			±0.1	%V _{DD}
Wake-up time at power up		MLX90320 operational, in spec.	0		10	ms
Output noise		10nF FLT capacitance			5	mV _{rms}
Output current capability			± 2.5			mA
Response time		Set by an external capacitor			0.1	ms

Table 3

G_{dido}	G_{dts}	G_{CS}	Fine Gain V/V	Typical Total Gain V/V	Sensor span in order to achieve 4V output span (mV) ¹	Typical total sensor offset that can be compensated to achieve 0.5V as MLX90320 output offset (mV)		Typical total sensor offset that can be compensated to achieve 4.5V as MLX90320 output offset (mV)	
0	0	0	0.448	12.7	196.1	-306.7	171.1	8.0	485.9
0	0	0	0.99	28.4		-328.3	149.6	-187.3	290.6
0	0	1	0.448	19.9	125.2	-320.8	157.1	-119.3	358.6
0	0	1	0.99	44.3		-334.6	143.3	-244.3	233.6
0	1	0	0.448	31.8	78.3	-329.0	147.9	-204.1	273.9
0	1	0	0.99	70.9		-338.6	139.3	-282.2	195.7
0	1	1	0.448	49.6	50.2	-335.6	142.3	-255.0	222.9
0	1	1	0.99	110.8		-341.1	136.8	-305.0	172.9
1	0	0	0.448	50.7	49.1	-76.9	42.9	2.0	121.9
1	0	0	0.99	113.2		-82.3	37.5	-47.0	72.9
1	0	1	0.448	79.2	31.5	-80.4	39.4	-29.9	90.0
1	0	1	0.99	176.8		-83.9	36.0	-61.3	58.6
1	1	0	0.448	126.7	19.7	-82.7	37.1	-51.2	68.7
1	1	0	0.99	282.9		-84.9	34.9	-70.8	49.1
1	1	1	0.448	197.9	12.6	-84.2	35.7	-63.9	55.9
1	1	1	0.99	441.8		-85.5	34.3	-76.5	43.4

¹ To be able to compensate the sensor sensitivity drift with temperature, the typical sensor output span that gives 4V as MLX90320 output span must be calculated for a fine gain in the middle of his range (i.e. 0.72 V/V)

6 Detailed Description

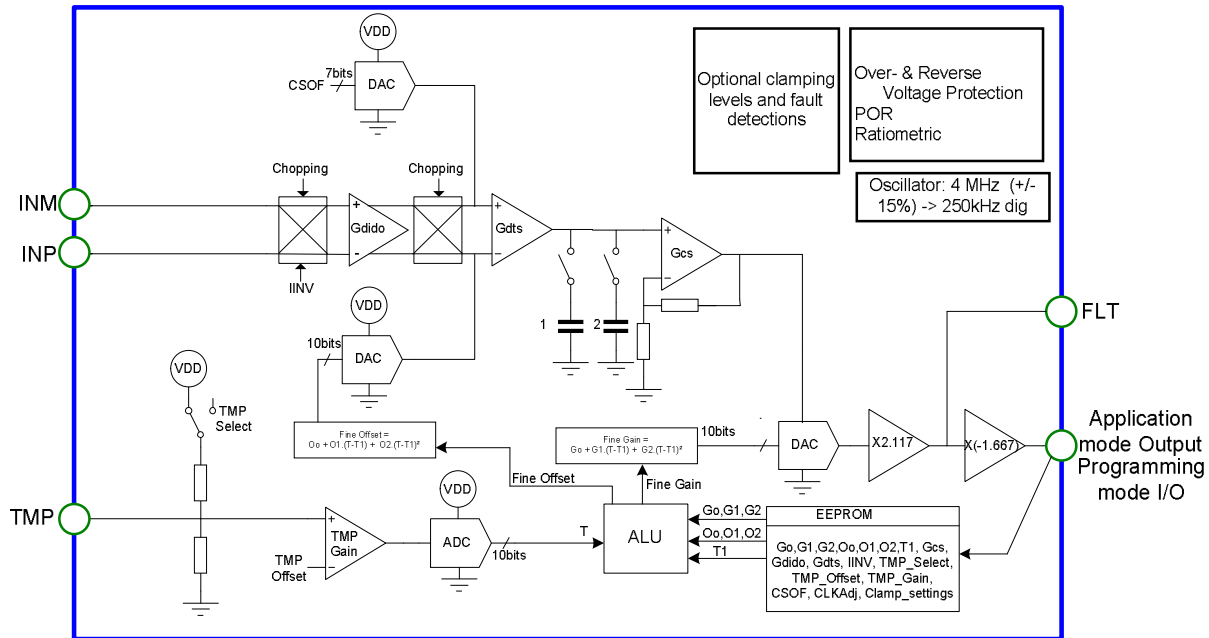

Figure 1: General block diagram of the MLX90320

The MLX90320 can be used with almost any type of resistive bridge sensor without the need of any additional signal conditioning.

The differential input signal is offset compensated and amplified to achieve the desired output voltage. With a coarse gain calibration the MLX90320 can easily accommodate sensor output spans in the 1.8mV/V to 63mV/V range to achieve 4 V output span. Sensor output offset in the 0.4mV/V to 97.2mV/V range (depending on the sensor output span and on the desired output offset, see table 3 for the details) can be compensated with the coarse offset calibration to achieve an output offset in the 0.5V to 4.5V range. Figure 2 shows two typical output characteristics that can be obtained with the calibration of the MLX90320. The option of swapping the inputs by setting one bit in EEPROM and the wide variation of the output offset with the coarse offset calibration allows calibrating a decreasing output characteristic as shown in figure 2. All output characteristics between those described in figure 2 can be achieved for a wide range of sensor output span and offset.

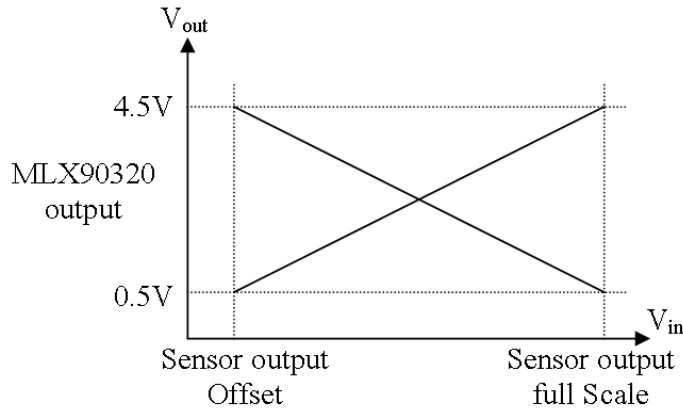

Figure 2: Two typical MLX90320 output characteristics obtained after calibration

Besides the coarse gain and offset adjustment, the MLX90320 can accurately adjust the output span and offset to the desired values by calibrating a fine gain and a fine offset 10 bits DAC. This fine calibration allows also compensating second order temperature drifts of the sensor sensitivity and offset. An accurate temperature chain gives the information needed to compensate this temperature drift. The user has the possibility of selecting between an internal or external temperature sensor by setting one bit in EEPROM.

What follows is the description of the different features of the MLX90320. For each feature the different calibrations parameters associated will be explained and their address in the EEPROM will be given. First the EEPROM will be described.

6.1 EEPROM

The EEPROM is a 64 x 5 bits memory. A detailed description of the EEPROM memory address map is given in the paragraph 9. So each EEPROM address contains 4 calibration bits and one parity bit. The sum of the '1's of the five bits must be '1'. That means that when data is '0000' the parity must be '1' (other examples: '0100' parity is '0'; '1100' parity is '1'; '1111' parity is '1').

6.2 The programmable clock.

The CLKADJ[3:0] bits are stored in address 3 of the EEPROM. These bits are used to program the oscillator. If CLKADJ[3:0] = 1111, the oscillator runs at the highest frequency. If CLKADJ[3:0] = 0000, the oscillator runs at the slowest frequency. This calibration is required to calibrate the 4 MHz oscillator within +/-15% accuracy. A bad oscillator calibration may cause malfunction of the communication protocol thus it is only factory set.

6.3 The temperature chain.

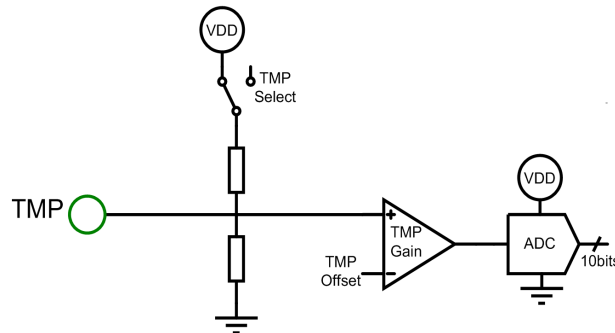

Figure 3 The temperature chain

The temperature chain is composed of the temperature sensor, an amplifier with programmable gain and offset and a SAR ADC.

The user can choose between an internal or an external temperature sensor. By setting the bit `TMP_Select` to 1 (EEPROM address 23) the internal temperature sensor is chosen and the `TMP` pin has to be left floating in application mode. If `TMP_Select` is 0 the external temperature sensor is chosen and an external resistor has to be connected between the supply voltage and the `TMP` pin. The MLX90320 should be used with an external temperature sensor only for applications where the temperature surrounding the customer sensor is different from the temperature surrounding the MLX90320. An example of external resistor that could be used in those specific applications is given in paragraph 8.

As the sensitivity and the offset of the temperature sensor can vary a lot from part to part, the temperature chain must be calibrated. For that reason the amplifier gain is three bits programmable (`TMP_GAIN` bits stored in EEPROM address 31). These three bits are used to calibrate the sensitivity of the temperature chain. The amplifier offset is five bits programmable (`TMP_OFFSET` bits stored in EEPROM address 23 and 27) and compensates the offset of the temperature sensor. After calibration the output of the temperature chain amplifier must be within the input range of the SAR ADC for the entire application temperature range.

When the calibration of the temperature chain is over, the 10 bits room temperature `T1` can be stored in the EEPROM (address 0 to 3 for the `T1` value used to calculate the fine gain and address 16 to 18 for `T1` value used to calculate the fine offset) and it will be used for the sensor signal chain offset and sensitivity temperature drift compensation.

6.4 The sensor signal chain.

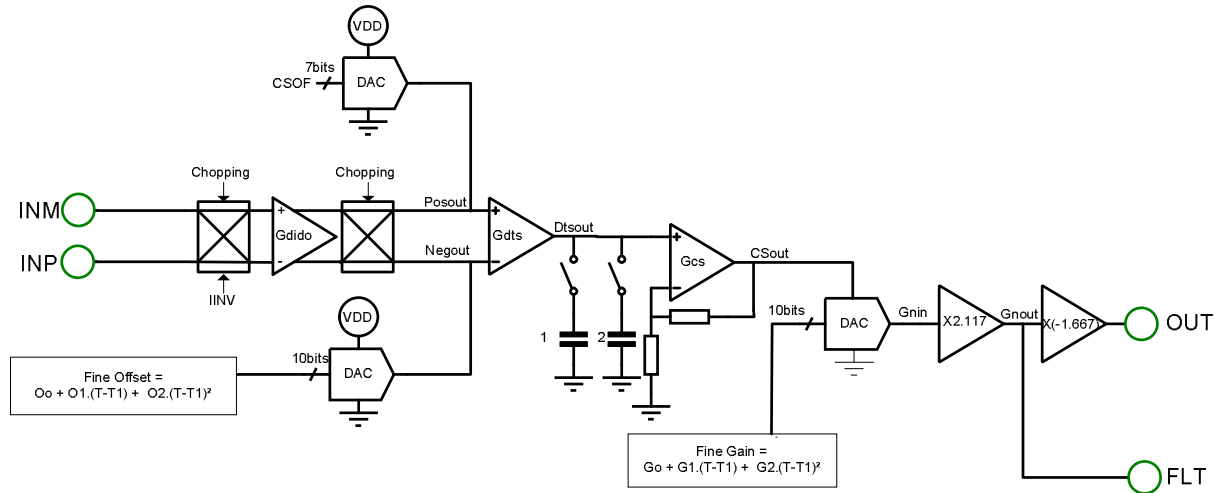

Figure 4 The sensor signal chain

The input of the sensor signal chain is a differential voltage INP-INM. The differential inputs can be inverted by setting the IINV bit (EEPROM address 7). This is done by a 180° phase shift of the chopping signal. This allows calibrating a decreasing output characteristic instead of an increasing one as shows Figure 2.

A dual input dual output 1 bit gain programmable amplifier (Gdido) is the first amplifier stage of the sensor signal chain. The use of noise and offset reduction techniques like chopping and sample and hold makes the contribution of the on-chip noise, offset and offset drift negligible compared to the same imperfections from the external sensor. A dual input single output 1 bit programmable gain amplifier (Gdts) and a 1 bit programmable gain charge summing amplifier (Gcs) completes the programmable coarse gain of the sensor signal chain. Thanks to the wide programmable coarse gain range, the MLX90320 can accommodate wide sensor output spans.

A coarse and fine sensor offset compensation is done at the inputs of the dual to single amplifier (Gdts). A fine gain DAC allows calibrating accurately the output span. A wide range of sensor offsets can be compensated with the coarse offset calibration while the desired output offset can be achieved accurately with the fine offset calibration. The fine gain and offset calibration allows compensating a second order temperature drift of the sensor sensitivity and offset. An external capacitor connected to the FLT pin sets the bandwidth of the MLX90320.

The global equations of the sensor signal chain are given below:

$$POS_{OUT} - NEG_{OUT} = \begin{cases} G_{DIDO} \times (INP - INM), & \text{if } _IINV = 0 \\ G_{DIDO} \times (INM - INP), & \text{if } _IINV = 1 \end{cases}$$

$$AGND = 0.7 \times V_{DD}$$

$$Dts_{OUT} = -G_{DTS} \times (POS_{OUT} - NEG_{OUT}) + \frac{G_{DTS}}{3} \times (FN_{OFF} - CS_{OFF}) + AGND$$

$$CS_{OUT} = G_{CS} \times (Dts_{OUT} - AGND) + AGND$$

$$Gn_{IN} = FN_{GAIN} \times (CS_{OUT} - AGND) + AGND$$

$$Gn_{OUT} = 2.117 \times (Gn_{IN} - AGND) + AGND$$

$$OUT = -1.667 \times Gn_{OUT} + 1.1668 \times V_{DD}$$

Explanation of the parameters used in the global equations:

- INP-INM is the differential output from the sensor
- IINV is the bit that swaps the MLX90320 inputs INP and INM
- POS_{out}, NEG_{out}, Dts_{out}, CS_{out}, Gn_{in} and Gn_{out} are MLX90320 internal nodes represented in the schematic of the sensor signal chain (fig 5)
- AGND is an analog ground dependent of the supply voltage V_{DD}.
- G_{DIDO}, G_{DTS}, G_{CS} form the sensor signal chain coarse gain programmable.
- FN_{OFF} and CS_{OFF} are respectively the sensor signal chain fine and coarse offset programmable.
- FN_{GAIN} is the sensor signal chain fine gain programmable.
- OUT is the application mode output of the MLX90320.

The different sensor chain calibration parameters with their range will be described in the following paragraphs.

6.4.1 The Gain calibration of the sensor signal chain.

Three programmable coarse gain stages allow calibrating a wide range of sensor output spans (1.8mV/V to 63mV/V range) to the desired MLX90320 output span. Amplifier DIDO is a differential input – differential output amplifier, while amplifier DTS and CS are dual-to-single-ended amplifiers giving a single ended output voltage referred to the ground.

Each one of these three amplifiers is one bit programmable:

- The DIDO gain is 3.25 or 13 depending on the value of the corresponding bit stored on the address 7 of the EEPROM.
- The DTS gain is 2 or 5 depending on the value of the corresponding bit stored on the address 7 of the EEPROM.
- The CS gain is 1.24 or 1.9375 depending on the value of the corresponding bit stored on the address 7 of the EEPROM.

Besides the three programmable coarse gain stages, there is also a 10 bits programmable fine gain stage within the range 44.88% to 99%. The fine gain calibration allows an accurate adjustment of the output span. The fine gain can be calculated by the formula:

$$FN_{GAIN} = (0.448 + FNGain_{real} \times (0.99 - 0.448))$$

Equation 1

Explanation of parameters used in equation 1:

- FN_{GAIN} is the fine gain used in the signal sensor chain.
- FNGain_{real} is the value of the fine gain in the [0..1] range with 10 bits resolution.

The fine gain calibration allows also a second order compensation of the drift with temperature of the sensor sensitivity. The value of the fine gain is given by the formula:

$$FNGain_{real} = G_0 + G_1 \times (T - T_1) + G_2 \times (T - T_1)^2$$

Equation 2

Explanation of parameters used in equation 2:

- ❑ T_1 is the output of the temperature chain corresponding to the room temperature. The ADC of the temperature chain outputs 10bits but 12 bits are stored (address 0 to 2 of the EEPROM). The MSB must always be 0 and the other 11 bits are obtained from an average of the previous temperature readings. This gives more accuracy to the output of the temperature chain. The T_1 value used in equation 2 is in the [0..1] range with an 11 bit resolution.
- ❑ G_0 is the zero order fine gain coefficient (independent from the temperature) used to adjust accurately the output span at room temperature. 12 bits are stored (address 12 to 14 of the EEPROM) but only the 10 first are used. The two MSB must be 0. The G_0 value used in equation 2 is in the [0..1] range with a 10 bit resolution.
- ❑ G_1 is the first order fine gain coefficient used to compensate the sensor sensitivity drift with temperature. 12 bits are stored (address 8 to 10 of the EEPROM). The MSB is the sign bit (two's complement): If $G1[11] = 1$ then G_1 is negative, if $G1[11] = 0$ then G_1 is positive. The G_1 value used in equation 2 is in the [-2..2] range with an 11 bit resolution.
- ❑ G_2 is the second order fine gain coefficient used to compensate the sensor sensitivity drift with temperature. 12 bits are stored (address 4 to 6 of the EEPROM). The MSB is the sign bit (two's complement): If $G2[11] = 1$ then G_2 is negative, if $G2[11] = 0$ then G_2 is positive. The G_2 value used in equation 2 is in the [-2..2] range with an 11 bit resolution.

The ALU computes equation 2 with 12 bits but the result is truncated to 10 bits because the Gain DAC is a 10 bit DAC. When the MLX90320 is not able to compensate for the sensor sensitivity drift with temperature, the fine gain calibration parameters stored in EEPROM will lead to a $FNGain_{real}$ value out of the [0..1] range. In this case the MLX90320 output voltage will go into a fault band to indicate that the output voltage is not reliable anymore. Typical total gains with the corresponding sensor offset ranges that can be compensated can be found in table 3.

6.4.2 The Offset calibration of the sensor signal chain.

The purpose of the 7-bit offset DAC is to be able to adjust the MLX90320 output offset anywhere in the 0.5V to 4.5V range. The voltage at the output of the coarse offset DAC can be calculated by the formula:

$$CSOff_{analog} = \left(4.52 - \frac{CSOff_{digital}}{127} \times (4.52 - 0.3) \right) \times \frac{V_{DD}}{5}$$

Equation 3

Explanation of parameters used in equation 1:

- ❑ $CSOff_{analog}$ is the voltage at the output of the coarse offset DAC.
- ❑ $CSOff_{digital}$ is the digital decimal value of the coarse offset (7 bits stored in address 11 and 15 of the EEPROM).

The voltage span at the output of the coarse offset DAC is large enough to allow the user to calibrate a decreasing output characteristic with for example 4.5V as output offset and 0.5V as output full scale. This output characteristic is only possible by inverting the inputs (setting the IINV bit).

Besides the programmable coarse offset, there is also a 10-bits programmable fine offset stage which allows adjusting the MLX90320 output offset with a high resolution (at least a resolution of 0.1% of the supply voltage). The voltage at the output of the fine offset DAC can be calculated by the formula:

$$FNOff_{analog} = (1.136 + FNOff_{real} \times (1.59 - 1.136)) \times \frac{V_{DD}}{5}$$

Equation 4

Explanation of parameters used in equation 4:

- $FNOff_{analog}$ is the voltage at the output of the fine offset DAC.
- $FNOff_{real}$ is the value of the fine offset in the [0..1] range with a 10 bit resolution.

The $\frac{V_{DD}}{5}$ term of equation 3 and 4 are due to the ratio-metric behaviour of the fine and coarse offset DACs.

The fine offset calibration allows also a second order compensation of the temperature drift of the sensor offset. The value of the fine offset is given by the formula:

Equation 5

$$FNOff_{real} = O_0 + O_1 \times (T - T_1) + O_2 \times (T - T_1)^2$$

Explanation of parameters used in equation 5:

- T_1 is the output of the temperature chain corresponding to the room temperature. The ADC of the temperature chain outputs 10 bits but 12 bits are stored (address 0 to 2 of the EEPROM). The MSB must always be 0 and the other 11 bits are obtained from an averaging from the previous temperature readings. This gives more accuracy to the output of the temperature chain. The T_1 value used in equation 5 is in the [0..1] range with an 11 bit resolution.
- O_0 is the zero order fine offset coefficient (independent from the temperature) used to compensate accurately the sensor offset at room temperature. 12 bits are stored (address 28 to 30 of the EEPROM) but only the 10 first are used. The two MSB must be 0. The O_0 value used in equation 5 is in the [0..1] range with a 10 bit resolution.
- O_1 is the first order fine offset coefficient used to compensate the sensor offset drift with temperature. 12 bits are stored (address 24 to 26 of the EEPROM). The MSB is the sign bit (two's complement): If $O1[11] = 1$ then O_1 is negative, if $O1[11] = 0$ then O_1 is positive. The O_1 value used in equation 5 is in the [-2..2] range with an 11 bit resolution.
- O_2 is the second order fine offset coefficient used to compensate the sensor offset drift with temperature. 12 bits are stored (address 20 to 22 of the EEPROM). The MSB is the sign bit (two's complement): If $O2[11] = 1$ then O_2 is negative, if $O2[11] = 0$ then O_2 is positive. The O_2 value used in equation 5 is in the [-2..2] range with an 11 bit resolution.

The ALU computes the equation 5 with 12 bits but the result is truncated to 10 bits because the Offset DAC is a 10 bit DAC. When the MLX90320 is not able to compensate for the sensor offset drift with temperature, the fine offset calibration parameters stored in EEPROM will lead to a $FNOff_{real}$ value out of the [0..1] range. In this case the MLX90320 output voltage will go into a fault band to indicate that the output voltage is not reliable anymore.

The MLX90320 also offers the possibility to set clamping levels to the output voltage. This allows creating fault bands necessary to detect external and internal faults.

6.4.3 The output clamping levels

The output voltage is in application mode limited by a 3-bit programmable low and 3-bit programmable high clamping-level. In order to set the clamping level in a high impedance node, the clamping is done at the FLT pin.

The FLT pin voltage is compared with the DA-converted value of CLAMPLOW_{dig} and CLAMPHIGH_{dig}. If the FLT pin voltage is greater than the DA-converted value of CLAMPHIGH_{dig}, then this last voltage is used as input of the output stage. If the FLT pin voltage is smaller than the DA-converted value of CLAMPLOW_{dig}, then this last voltage is used as input of the output stage. The transition from in range mode to clamping mode and vice versa takes place without overshoot.

The output pin low clamping level can be calculated by the formula :

Equation 6

$$V_{out_{lowclamp}} = (Low_{clamp} + Clamp_{low_{dig}} \times 0.013) \times V_{DD}$$

Explanation of parameters used in equation 6:

- $V_{out_{lowclamp}}$ is the output pin low clamping voltage.
- Low_{clamp} is the lowest clamp level and has a typical value of 4% +/-1% variation from sample to sample.
- $Clamp_{low_{dig}}$ is the decimal value (range of 0 to 7) of the low clamp level stored in EEPROM at the address 19.

The output pin high clamp level can be calculated by the formula:

Equation 7

$$V_{out_{highclamp}} = (High_{clamp} + (Clamp_{high_{dig}} - 7) \times 0.013) \times V_{DD}$$

Explanation of parameters used in equation 7:

- $V_{out_{highclamp}}$ is the output pin high clamping voltage.
- $High_{clamp}$ is the highest clamp level and has a typical value of 96% +/-1% variation from sample to sample.
- $Clamp_{high_{dig}}$ is the decimal value (range of 0 to 7) of the high clamp level stored in EEPROM at the address 19 and 23.

6.4.4 The Faults detection

As mentioned before, a reliable memory is obtained by storing each bit three times in the EEPROM and by using parity check to detect data corruption and majority voting when accessing the data. Thanks to the setting of output clamping levels, the MLX90320 output voltage goes to the fault bands to point out that a fault occurred and that the output signal is unreliable. The MLX90320 contains circuitry which detects and diagnoses the following faults with the loads as described and specified in and under the conditions of paragraph 5:

Internal faults

Fault detection of INP and INM have the levels at 1.5 and 3.5 Volt (with 5 Volt supply).

- INP and/or INM open
- Sensing element supply open
- Short-circuit of INP and/or INM with VDD
- Short-circuit of INP and/or INM with GND
- Short-circuit of FLT with VDD or GND

When a short-circuit of FLT with VDD occurs the output goes to the high fault band. For all other internal faults the output goes to the low fault band.

External faults

Short-circuit

- Output with VDD
- Output with GND
- Output with Vbat

In all of these above mentioned fault cases, the IC will generate an output within either of the diagnostic bands.

Open circuit

- VDD open
- GND open

In case of open circuit the output will go to the high fault band.

The MLX90320 must survive to the following reversed contacts but the output does not go to the fault bands.

- Reverse polarity
- Reverse battery polarity
- Output reversed with GND
- Output reversed with VDD

6.5 Programming the MLX90320 through the output pin

Communicating with the MLX90320 only requires a limited amount of interface circuitry, software and a computer. Melexis provides a communication equipment and belonging software such that the customer is able to start communicating with the chip in a matter of minutes.

The output pin acts as analog output pin and as communication pin.
The drive stage of a class AB amplifier is connected to that pin to output the analog output signal.
For the communication the output will be sink/source current source.
Through a short circuit detection, the ASSP knows that the user requests the pin for communication.

6.5.1 Overview

When the user wants to communicate with the MLX90320, communication must be requested.
This can be achieved by short-circuiting the output pin to ground and supply level.
The ASSP detects this short and after a delay time, the same output pin turns into a half-duplex digital communication channel.

6.5.2 Communication Request

1) Pattern to enter the communication mode

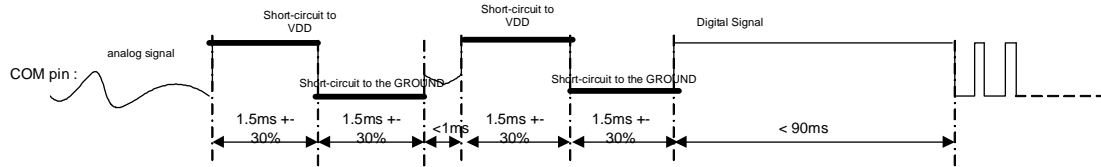

2) First case : the analog level is quite high :

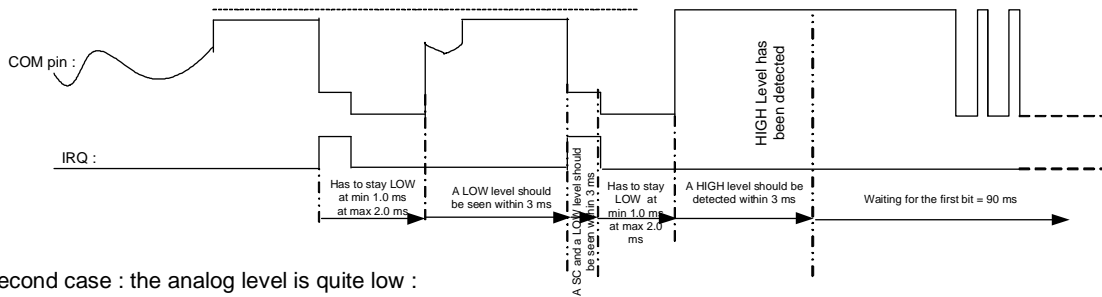

3) Second case : the analog level is quite low :

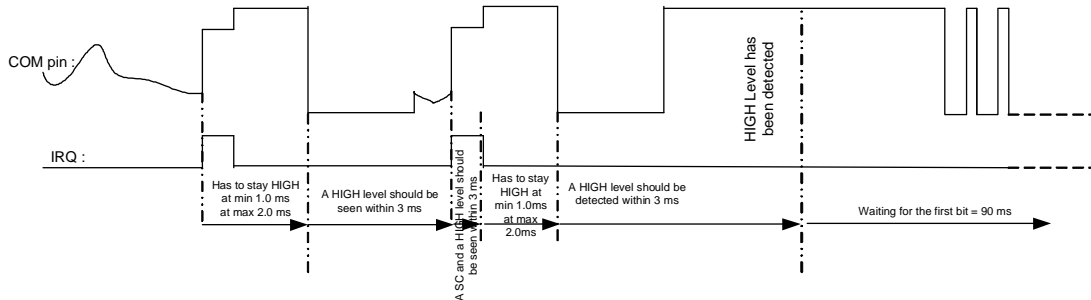

The default mode is the receive mode. The user has to send a valid command to the interface chip.

6.5.3 Bit format

The bit is coded into a pulse width modulated format (PWM).

PWM format has no need for message frame synchronization. This has the advantage that the receive speed can differ from the transmit speed. There is no configuration needed, the receiver can work with various bit rates.

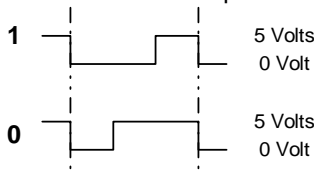

A valid bit always starts with a falling edge. This means that after making a communication request by shorting to ground, the user must reset the output line to high status.

Duty cycle: 30 / 70% (min = 20 / 80%, max = 40 / 60%)

Period: (Over total clock frequency range)

Data sent by the MLX90320			Data received by the MLX90320		
Period Length (µs)			Period Length (µs)		
Minimum	Typical	Maximum	Minimum	Typical	Maximum
1	510	695	1250	1700	2250

6.5.4 Commands

All delays mentioned below are calculated for a typical clock-frequency of 4 MHz. The clock frequency can differ +/- 15% on each chip. The delays will vary proportionally.

Stop communication mode

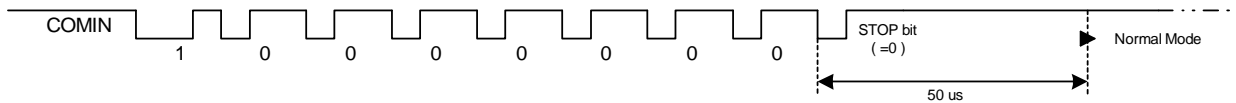

Stop the communication, ASSP goes back into normal mode. A new communication request is needed to get back into communication mode.

Reply A5

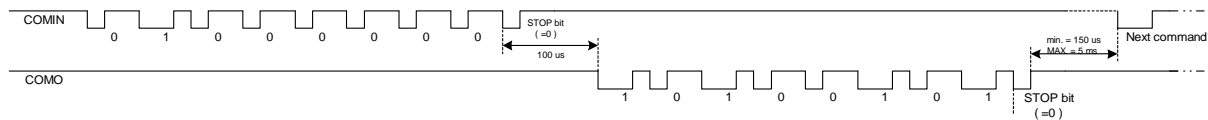

Command to see whether or not the ASSP is still in communication mode. If so, the ASSP shall respond \$A5.

Write to EEPROM

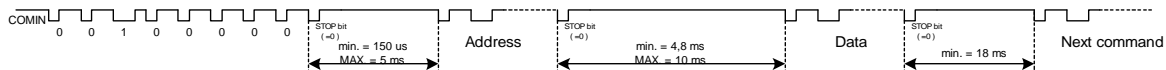

Write to a specific address. The address in the EEPROM is coded with 8 bits. As the EEPROM has 64 addresses the two first address bits should be 0. The data to store in one EEPROM address is coded with 8 bits. As each EEPROM address stores 4 calibration data bits and one parity bit, the 3 first data bits from the data byte should be 0.

Read from EEPROM

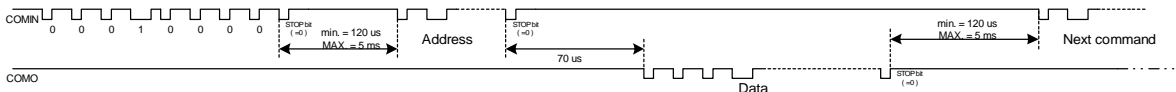

Read a specific address. The address in the EEPROM is coded with 8 bits. As the EEPROM has 64 addresses the two first address bits should be 0. A data byte is returned when reading the data from one EEPROM address but actually it contains four calibration data bits and one parity bit. So the 3 first bits read from an EEPROM address should be 0.

Read ADC value of the temperature.

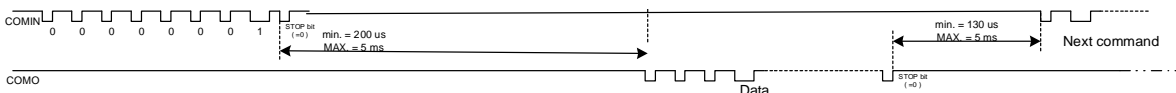

Read the digital temperature value.

The ASSP is sending back the first byte, followed a few μs later by the second byte.

One must readout 10bits data from these two byte.

The first byte are the 8 MSB bits of the ADC. The two highest bits of the second byte are the LSB bits of the ADC.

Lock EEPROM

To avoid unwanted rewriting of the EEPROM content in the field, it is strongly recommended to lock the EEPROM after calibration has been finished. For that purpose the 'Lock EEPROM' command can be used. The customer cannot undo the 'Lock EEPROM' command. This can only be done by Melexis using a special setup.

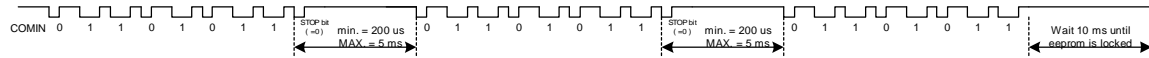

INM or INP connected to output

Test INP

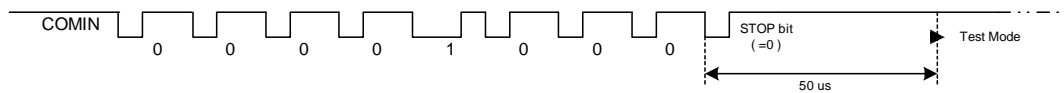

Connect INP input pin to the output. This mode can be left only by resetting the chip.

Test INM

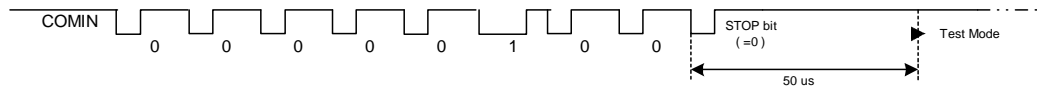

Connection INM input pin to the output. This mode can be left only by resetting the chip.

With communication one can select a mode where the INM or the INP signal is connected to the output. The chip stays in that mode until a reset is given. This can be used for failure analysis.

7 Unique Features

Offset canceling

The offset of amplifier DIDO is cancelled by using a chopping mechanism. Also the amplifier DTS and all sample-and-hold circuits make use of an offset canceling mechanism. This means that the contribution of the on-chip offsets and offset drifts is negligible compared to the external sensor offset and offset drift.

Coarse and fine second order calibration of the sensitivity and offset.

The MLX90320 can be calibrated to achieve 4V output span for a sensor output span in the 1.8mV/V to 63mV/V and can compensate 0.4mV/V to 97.2mV/V input offset depending on the sensor output span and on the desired MLX90320 output offset voltage. A wide range of sensor sensitivity and offset temperature drift can be compensated with the second order fine gain and offset calibration.

Clamping levels and fault detection on signal

The user can program a low and a high output voltage clamping level and thus create fault bands. Thanks to the fault bands creation, internal or external faults can be detected because they force the output voltage to go into a fault band. See paragraph 6 for more detailed explanations.

EEPROM

All the calibration data is stored three times on an EEPROM and a majority voting is done when accessing data. Parity check is used to diagnose data corruption. After all calibrations parameters were successfully written to EEPROM, the EEPROM can be locked by sending a 'Lock EEPROM' command (see paragraph 6). This is strongly recommended to avoid in application mode data corruption. For reliability reasons, actually each calibration bit is stored three times in the EEPROM and the circuit uses a hardware majority voting system when accessing data.

8 Typical applications circuits

8.1 Ratio-metric mode with use of external temperature sensor.

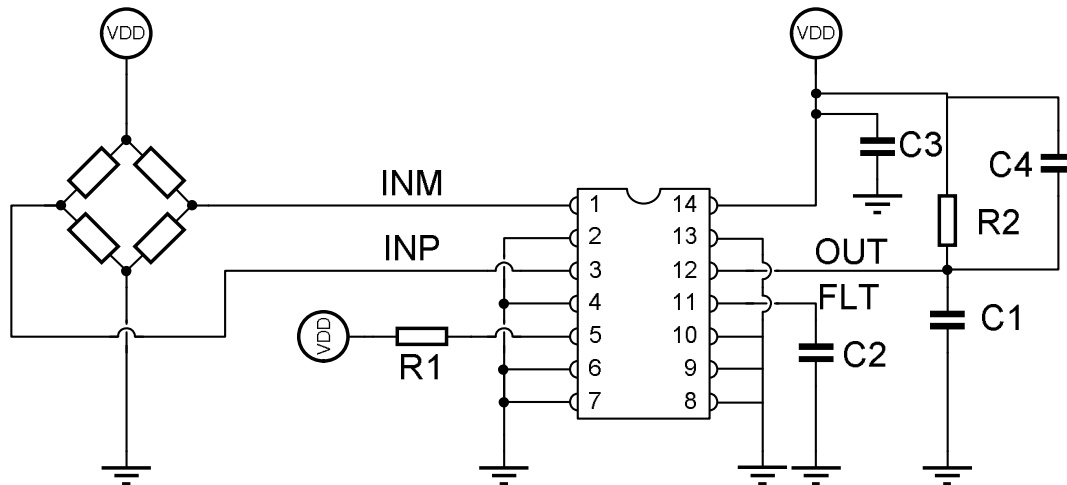

The external temperature sensor is only needed for applications where the temperature surrounding the customer sensor is different from the temperature surrounding the MLX90320. In the ratio-metric application mode, to keep the accuracy, the same supply should be used for the customer sensor, the MLX90320 and an ADC that makes the digital conversion of the analog output signal.

The capacitor C1 on the output is typical 47nF. Range: 0 – 100nF.

The capacitor C2 on the FLT pin is optional. Typical value = 10nF. Range: 0 – 100nF. It is used to decrease the noise and set the bandwidth of the system.

The decoupling capacitors C3 between the supply and the ground and C4 between output and supply have a typical value of 47nF.

The external resistor R1 is placed between the TMP pin and the supply. It is used as an external temperature sensor. The external temperature sensor could be of type Panasonic, ERAS15J103V (R1 = 10k +/- 5%, TCR = 1500ppm/degC +/- 200ppm/degC) for the -40°C to 140°C temperature range. The resistor R2 is an external pull up resistor with a typical value of 2kOhm.

8.2 Ratio-metric mode without use of external temperature sensor.

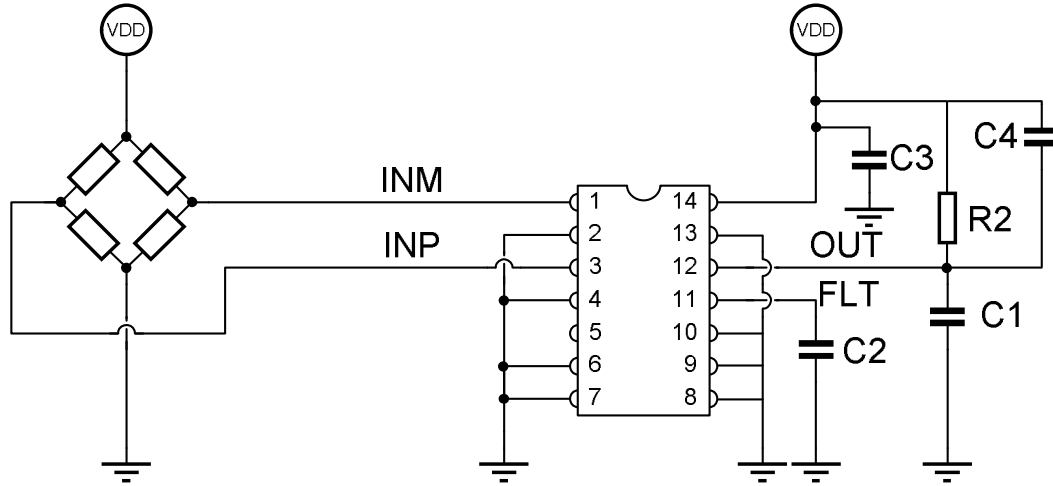

C1, C2, C3, C4 and R2 have the same values as for the ratio-metric application with use of external temperature sensor.

The internal temperature sensor can be used when the temperature surrounding the customer sensor and the MLX90320 is the same.

8.3 Non Ratio-metric mode with use of external temperature sensor.

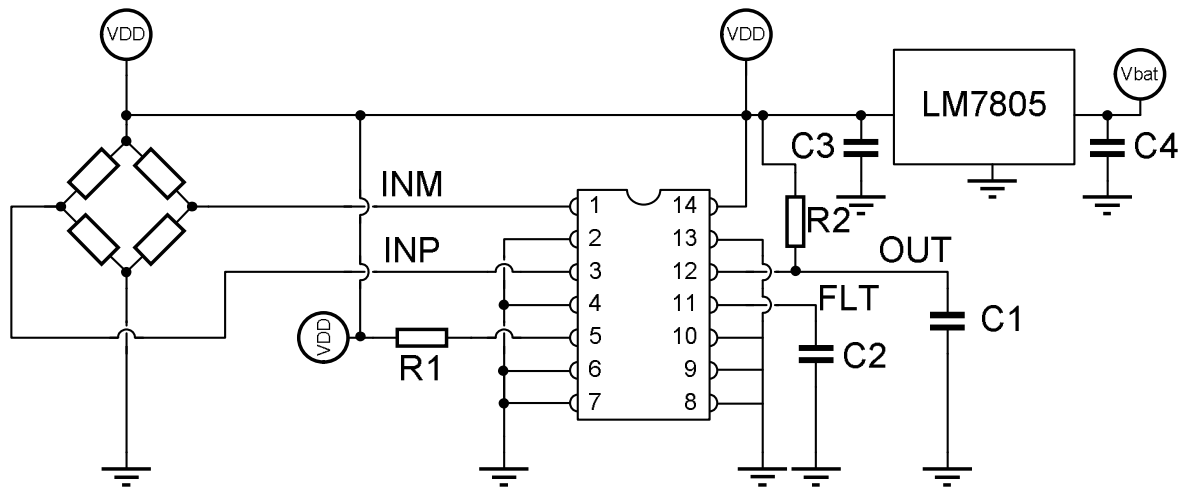

With the use of an external voltage regulator to supply the sensor, the MLX90320 as well as an ADC used for converting the analog output signal, the MLX90320 can be used in a non ratio-metric mode. An example of standard voltage regulator is the LM7805. C1, C2, R1 and R2 are the same as in the ratio-metric application mode. C4 has a typical value of 330nF and C3 of 100nF in this application mode.

8.4 Non Ratio-metric mode without use of external temperature sensor.

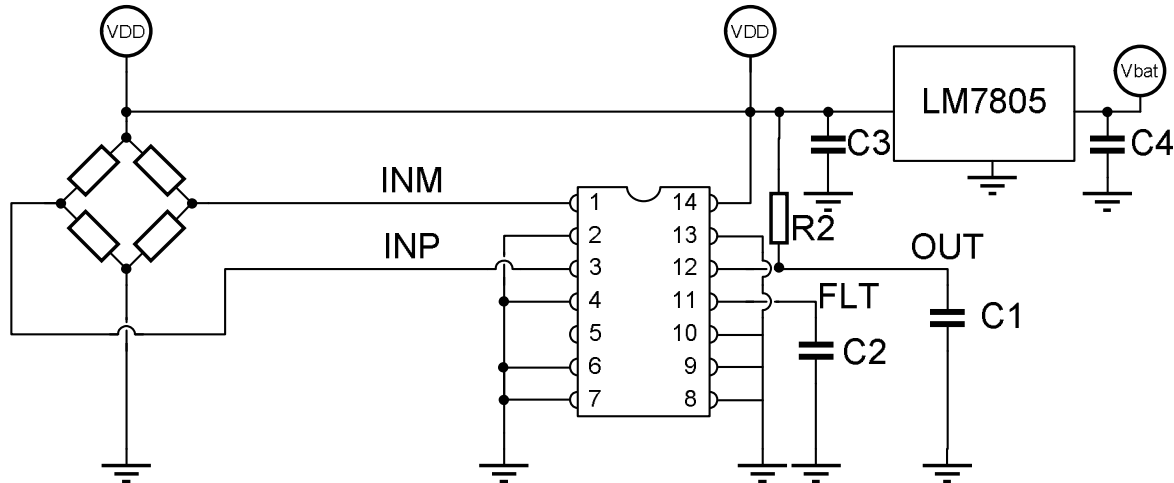

In this application mode the LM7805 generates the supply for the sensor, for the MLX90320 and for an ADC used to convert the analog output signal in a digital value. C1, C2, C3, C4 and R2 are the same as in the non ratio-metric application mode with external temperature sensor.

9 EEPROM Contents

Address Decimal	Bits	EEPROM content	Comments
0 to 2	0 to 3	T1 for Gain DAC	Contains the value of T1 used to calculate the fine gain in order to operate the second order compensation of the sensor span drift with temperature.
3	0 to 3	CLKADJ[3:0]	These bits are used to program the oscillator. If CLKADJ[3:0] = 1111, the oscillator runs at the highest frequency. If CLKADJ[3:0] = 0000, the oscillator runs at the slowest frequency. This calibration is required to calibrate the oscillator within +/-15% accuracy. A bad oscillator calibration may cause malfunction of the communication protocol thus it is only factory set.
4 to 6	0 to 3	G2 for Gain DAC	Contains the second order fine gain coefficient used to compensate the sensor sensitivity drift with temperature. The MSB is the sign bit (two's complement): If G2[11] = 1 then G2 is negative, if G2[11] = 0 then G2 is positive.
7	0	IINV	Bit used to invert the inputs
7	1 to 3	CG[2..0]	3 bits used to operate the coarse gain calibration.

			CG[2:0] = 111 means maximum gain ($13 \times 5 \times 1.9375$) and CG[2:0] = 000 means minimum gain ($3.25 \times 2 \times 1.24$).
8 to 10	0 to 3	G1 for Gain DAC	Contains the first order fine gain coefficient used to compensate the sensor sensitivity drift with temperature. The MSB is the sign bit (two's complement): If G1[11] = 1 then G1 is negative, if G1[11] = 0 then G1 is positive.
11 15	0 to 3 1 to 3	CSOF[6..0]	7 bits used to operate the coarse offset calibration.
12 to 14	0 to 3	G0 for Gain DAC	Contains the zero order fine gain coefficient (independent from the temperature) used to adjust accurately the output span at room temperature. 12 bits are stored but only the 10 first are used. The two MSB must be 0.
15	0	ClampSet	Bit used to enable (when ClampSet = 1) or disable (when Clampset = 0) the clamping
16 to 18	0 to 3	T1 for Offset DAC	Contains the value of T1 used to calculate the fine offset in order to operate the second order compensation of the offset drift with temperature.
19 23	0 to 3 2 and 3	CLAMP[5..0]	6 bits used for calibrating the clamping levels. CLAMP[2:0] are used for the low clamp levels (000 gives 4% at output and 111 gives 14% at output) and CLAMP[5:3] are used for the high clamp levels (000 gives 86% at output and 111 gives 96% at output).
20 to 22	0 to 3	O2 for Offset DAC	Contains the second order fine offset coefficient used to compensate the offset drift with temperature. The MSB is the sign bit (two's complement): If O2[11] = 1 then O2 is negative, if O2[11] = 0 then O2 is positive.
23 27	0 0 to 3	TMP_OFFSET[4:0]	These 5 bits are used to calibrate the offset of the external temperature sensor. If TMP_OFFSET[4:0] = 11111 then the TMP pin has the lowest voltage. If TMP_OFFSET[4:0] = 00000 then the TMP pin has the highest voltage. Goal is to calibrate in the neighbourhood of 2.5V. The internal temperature sensor offset calibration is only factory set.
23	1	TMP_SELECT	Bit used to choose between an internal or an external temperature sensor. If TMP_SELECT = 1 then the internal temperature sensor is chosen else an external temperature sensor is needed.
24 to 26	0 to 3	O1 for Offset DAC	Contains the first order fine offset coefficient used to compensate the offset drift with temperature. The MSB is the sign bit (two's complement): If O1[11] = 1 then O1 is negative, if O1[11] = 0 then O1 is positive.
28 to 30	0 to 3	O0 for Offset DAC	Contains the zero order fine offset coefficient (independent from the temperature) used to compensate accurately the sensor offset at room temperature. 12 bits are stored but only the 10 first are used. The two MSB must be 0.
31	0	NOT USED	
31	1 to 3	TMP_GAIN[2:0]	These 3 bits are used to calibrate the gain of the

			external temperature sensor. If TMP_GAIN[2:0] = 111, the gain is the highest. If TMP_GAIN[2:0] = 000, the gain is the lowest. The gain is calibrated in that way that the temperature sensor output is within the ADC range. The internal temperature sensor gain calibration is only factory set.
32 to 54	0 to 4	Customer	EEPROM space for the customer use. Can be used for example to store an ID number and the date.
55 to 63	0 to 4	Melexis	EEPROM space for Melexis use only.

Table 4 EEPROM contents description.

Address\bits	0	1	2	3	4
0	T1[0]	T1[1]	T1[2]	T1[3]	Parity
1	T1[4]	T1[5]	T1[6]	T1[7]	Parity
2	T1[8]	T1[9]	T1[10]	T1[11]	Parity
3	CLKADJ3	CLKADJ2	CLKADJ1	CLKADJ0	Parity
4	G2[0]	G2[1]	G2[2]	G2[3]	Parity
5	G2[4]	G2[5]	G2[6]	G2[7]	Parity
6	G2[8]	G2[9]	G2[10]	G2[11]	Parity
7	IINV	CG2	CG1	CG0	Parity
8	G1[0]	G1[1]	G1[2]	G1[3]	Parity
9	G1[4]	G1[5]	G1[6]	G1[7]	Parity
10	G1[8]	G1[9]	G1[10]	G1[11]	Parity
11	CSOF3	CSOF2	CSOF1	CSOF0	Parity
12	G0[0]	G0[1]	G0[2]	G0[3]	Parity
13	G0[4]	G0[5]	G0[6]	G0[7]	Parity
14	G0[8]	G0[9]	G0[10]	G0[11]	Parity
15	ClampSet	CSOF6	CSOF5	CSOF4	Parity
16	T1[0]	T1[1]	T1[2]	T1[3]	Parity
17	T1[4]	T1[5]	T1[6]	T1[7]	Parity
18	T1[8]	T1[9]	T1[10]	T1[11]	Parity
19	Clamp3	Clamp2	Clamp1	Clamp0	Parity
20	O2[0]	O2[1]	O2[2]	O2[3]	Parity
21	O2[4]	O2[5]	O2[6]	O2[7]	Parity
22	O2[8]	O2[9]	O2[10]	O2[11]	Parity
23	TMP_offset0	TMP_select	Clamp5	Clamp4	Parity
24	O1[0]	O1[1]	O1[2]	O1[3]	Parity
25	O1[4]	O1[5]	O1[6]	O1[7]	Parity
26	O1[8]	O1[9]	O1[10]	O1[11]	Parity
27	TMP_offset4	TMP_offset3	TMP_offset2	TMP_offset1	Parity
28	O0[0]	O0[1]	O0[2]	O0[3]	Parity
29	O0[4]	O0[5]	O0[6]	O0[7]	Parity
30	O0[8]	O0[9]	O0[10]	O0[11]	Parity
31	Not used	TMP_gain2	TMP_gain1	TMP_gain0	Parity

Table 5 EEPROM calibration data contents

32	Cust	Cust	Cust	Cust	Cust
33	Cust	Cust	Cust	Cust	Cust
34	Cust	Cust	Cust	Cust	Cust
35	Cust	Cust	Cust	Cust	Cust
36	Cust	Cust	Cust	Cust	Cust
37	Cust	Cust	Cust	Cust	Cust
38	Cust	Cust	Cust	Cust	Cust
39	Cust	Cust	Cust	Cust	Cust
40	Cust	Cust	Cust	Cust	Cust
41	Cust	Cust	Cust	Cust	Cust
42	Cust	Cust	Cust	Cust	Cust
43	Cust	Cust	Cust	Cust	Cust
44	Cust	Cust	Cust	Cust	Cust
45	Cust	Cust	Cust	Cust	Cust
46	Cust	Cust	Cust	Cust	Cust
47	Cust	Cust	Cust	Cust	Cust
48	Cust	Cust	Cust	Cust	Cust
49	Cust	Cust	Cust	Cust	Cust
50	Cust	Cust	Cust	Cust	Cust
51	Cust	Cust	Cust	Cust	Cust
52	Cust	Cust	Cust	Cust	Cust
53	Cust	Cust	Cust	Cust	Cust
54	Cust	Cust	Cust	Cust	Cust
55	Mix	Mix	Mix	Mix	Mix
56	Mix	Mix	Mix	Mix	Mix
57	Mix	Mix	Mix	Mix	Mix
58	Mix	Mix	Mix	Mix	Mix
59	Mix	Mix	Mix	Mix	Mix
60	Mix	Mix	Mix	Mix	Mix
61	Mix	Mix	Mix	Mix	Mix
62	Mix	Mix	Mix	Mix	Mix
63	Mix	Mix	Mix	Mix	Mix

Table 6 EEPROM contents of Customer and Melexis general purpose data

10 Reliability Information

This Melexis device is classified and qualified regarding soldering technology, solderability and moisture sensitivity level, as defined in this specification, according to following test methods:

- IPC/JEDEC J-STD-020
Moisture/Reflow Sensitivity Classification For Nonhermetic Solid State Surface Mount Devices (classification reflow profiles according to table 5-2)
- EIA/JEDEC JESD22-A113
Preconditioning of Nonhermetic Surface Mount Devices Prior to Reliability Testing (reflow profiles according to table 2)
- CECC00802
Standard Method For The Specification of Surface Mounting Components (SMDs) of Assessed Quality
- EIA/JEDEC JESD22-B106
Resistance to soldering temperature for through-hole mounted devices
- EN60749-15
Resistance to soldering temperature for through-hole mounted devices
- MIL 883 Method 2003 / EIA/JEDEC JESD22-B102
Solderability

For all soldering technologies deviating from above mentioned standard conditions (regarding peak temperature, temperature gradient, temperature profile etc) additional classification and qualification tests have to be agreed upon with Melexis.

The application of Wave Soldering for SMDs is allowed only after consulting Melexis regarding assurance of adhesive strength between device and board.

Based on Melexis commitment to environmental responsibility, European legislation (Directive on the Restriction of the Use of Certain Hazardous substances, RoHS) and customer requests, Melexis has installed a Roadmap to qualify their package families for lead free processes also.

Various lead free generic qualifications are running, current results on request.

For more information on manufacturability/solderability see quality page at our website:
<http://www.melexis.com/html/pdf/MLXleadfree-statement.pdf>

11 ESD Precautions

Electronic semiconductor products are sensitive to Electro Static Discharge (ESD).

Always observe Electro Static Discharge control procedures whenever handling semiconductor products.

12 Package Information

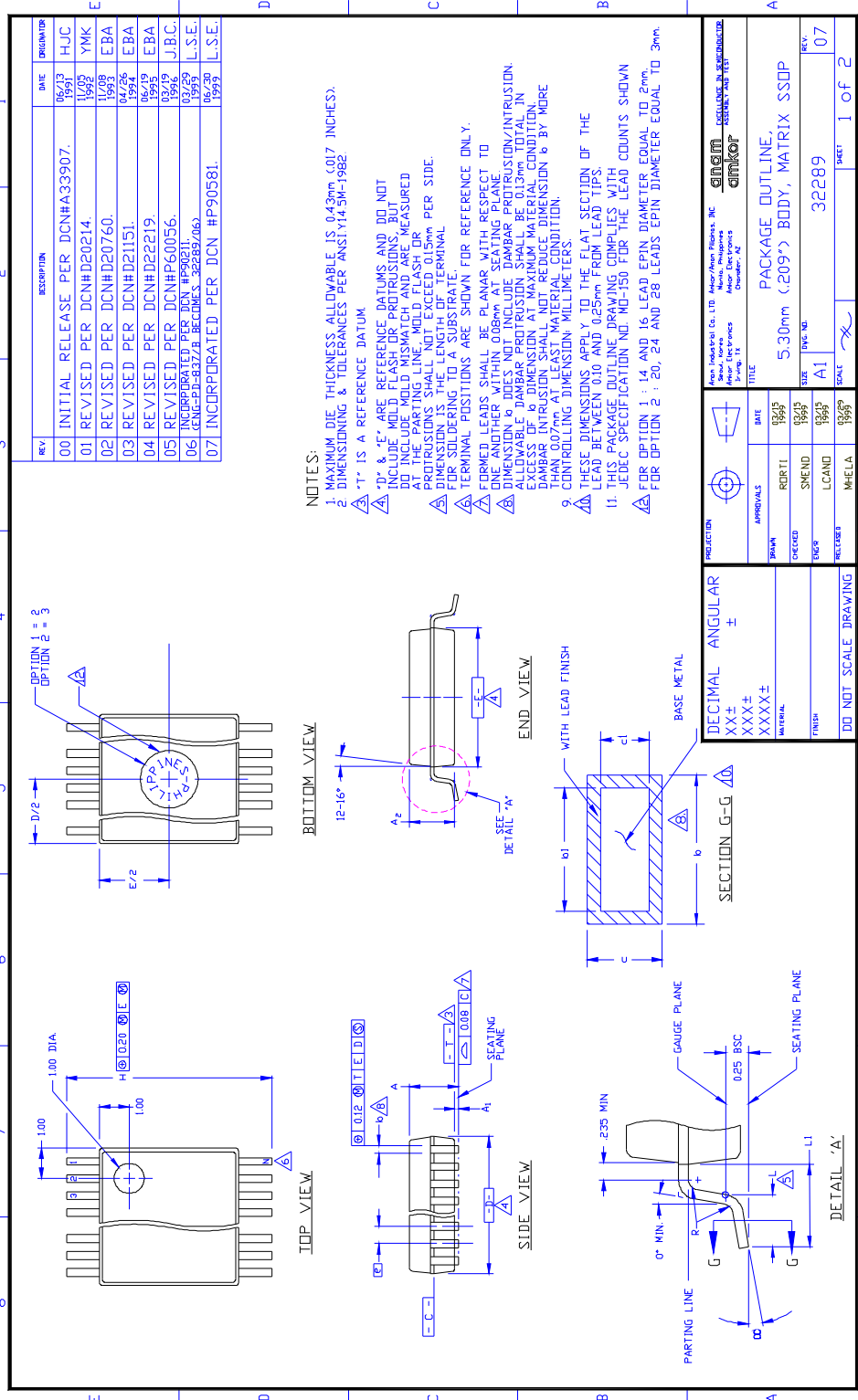

Feature	COMMON DIMENSIONS			NOTE VARIATIONS	DIMENSIONS			Feature
	MIN.	NOM.	MAX.		MIN.	NOM.	MAX.	
A	1.73	1.86	1.99	AA	6.07	6.20	6.33	14
A ₁	0.05	0.13	0.21	AB	6.07	6.20	6.33	16
A ₂	1.68	1.73	1.78	AC	7.07	7.20	7.33	20
b	0.25	-	0.38	AD	8.07	8.20	8.33	24
b ₁	0.25	0.30	0.33	AE	10.07	10.20	10.33	28
c	0.09	-	0.20	AF	10.07	10.20	10.33	30
c ₁	0.09	0.15	0.16					
D	SEE VARIATIONS 4							
E	5.20	5.30	5.38					
e	0.65 BSC							
H	7.65	7.80	7.90					
L	0.63	0.75	0.95					
L ₁	1.25 REF.							
N	SEE VARIATIONS 6							
α	0°	4°	8°					
R	0.09	0.15						

THIS TABLE IN MILLIMETERS

VARIATION AF
IS DESIGNED BUT NOT TOOLED

Feature	COMMON DIMENSIONS			NOTE VARIATIONS	DIMENSIONS			Feature
	MIN.	NOM.	MAX.		MIN.	NOM.	MAX.	
A	.068	.073	.078	AA	.239	.244	.249	14
A ₁	.002	.005	.008	AB	.239	.244	.249	16
A ₂	.066	.068	.070	AC	.278	.284	.289	20
b	.010	-	.015	AD	.318	.323	.328	24
b ₁	.010	.012	.013	AE	.397	.402	.407	28
c	.004	-	.008	AF	.397	.402	.407	30
c ₁	.004	.006	.006					
D	SEE VARIATIONS 4							
E	.205	.209	.212					
e	.0256 BSC							
H	.301	.307	.311					
L	.025	.030	.037					
L ₁	.049 REF.							
N	SEE VARIATIONS 6							
α	0°	4°	8°					
R	.004	.006						

THIS TABLE IN INCHES

TITLE		PACKAGE OUTLINE, 5.30mm (.209") BODY, MATRIX SSDP	
SIZE	PAGE NO	REV	
A1	32289	07	
SCALE	8/1	SHEET	2 of 2

13 Disclaimer

Devices sold by Melexis are covered by the warranty and patent indemnification provisions appearing in its Term of Sale. Melexis makes no warranty, express, statutory, implied, or by description regarding the information set forth herein or regarding the freedom of the described devices from patent infringement. Melexis reserves the right to change specifications and prices at any time and without notice. Therefore, prior to designing this product into a system, it is necessary to check with Melexis for current information. This product is intended for use in normal commercial applications. Applications requiring extended temperature range, unusual environmental requirements, or high reliability applications, such as military, medical life-support or life-sustaining equipment are specifically not recommended without additional processing by Melexis for each application.

The information furnished by Melexis is believed to be correct and accurate. However, Melexis shall not be liable to recipient or any third party for any damages, including but not limited to personal injury, property damage, loss of profits, loss of use, interrupt of business or indirect, special incidental or consequential damages, of any kind, in connection with or arising out of the furnishing, performance or use of the technical data herein. No obligation or liability to recipient or any third party shall arise or flow out of Melexis' rendering of technical or other services. © 2002 Melexis NV. All rights reserved.

For the latest version of this document, go to our website at
www.melexis.com

Or for additional information contact Melexis Direct:

Europe and Japan:	All other locations:
Phone: +32 1367 0495	Phone: +1 603 223 2362
E-mail: sales_europe@melexis.com	E-mail: sales_usa@melexis.com

ISO/TS 16949 and ISO14001 Certified