

## MMIC Silicon Bipolar Broadband Amplifier

The ISL55012 is a high performance gain block featuring a Darlington configuration using high  $f_T$  transistors and excellent thermal performance. They are an ideal choice for DVB-S LNB cable receiver applications.

Other members of the family include:

ISL55012 and ISL55015 match a  $75\Omega$  source to a  $50\Omega$  load.  
ISL55013 and ISL55014 match a  $50\Omega$  source to a  $50\Omega$  load.

### Ordering Information

PART NUMBER (Note)	PART MARKING	PACKAGE (Pb-Free)	PKG. DWG. #
ISL55012IEZ-T7	CCG	6 Ld SC-70	P6.049A

\* Please refer to TB347 for details on reel specifications.

NOTE: Intersil Pb-free plus anneal products employ special Pb-free material sets; molding compounds/die attach materials and 100% matte tin plate termination finish, which are RoHS compliant and compatible with both SnPb and Pb-free soldering operations. Intersil Pb-free products are MSL classified at Pb-free peak reflow temperatures that meet or exceed the Pb-free requirements of IPC/JEDEC J STD-020.

### Typical Application Circuit

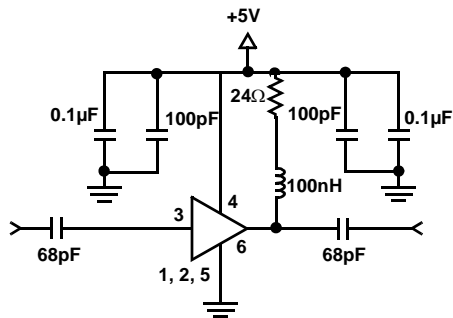

### Features

- Input impedance of  $75\Omega$
- Output impedance of  $50\Omega$
- Gain of 18dB @ 1GHz
- Noise figure of 4.7dB @ 2GHz
- OIP3 of 30dBm @ 1GHz
- Low input and output return losses
- Pb-free available (RoHS compliant)

### Applications

- LNB and LNB-T (HDTV) amplifiers
- IF gain blocks for satellite and terrestrial STBs
- PA driver amplifier
- Wireless data, satellite
- Bluetooth/WiFi
- Satellite locator and signal strength meters

### Pinout

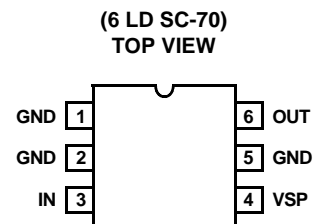

**Absolute Maximum Ratings** ( $T_A = +25^\circ\text{C}$ )

Supply Voltage from VSP to GND ..... 6V  
 Input Voltage .....  $V_{S+} +0.3\text{V}$  to GND  $-0.3\text{V}$   
 Ambient Operating Temperature .....  $-40^\circ\text{C}$  to  $+85^\circ\text{C}$   
 Storage Temperature .....  $-65^\circ\text{C}$  to  $+125^\circ\text{C}$   
 Operating Junction Temperature .....  $+135^\circ\text{C}$   
**ESD Rating**  
 Human Body Model (Per MIL-STD-883 Method 3015.7) ... 6000V  
 Machine Model (Per EIAJ ED-4701 Method C-111) ..... 3000V  
 Storage Temperature .....  $-65^\circ\text{C}$  to  $+125^\circ\text{C}$   
 Operating Junction Temperature .....  $+135^\circ\text{C}$

**Thermal Information**

Thermal Resistance (Typical)  $\theta_{JA}$  ( $^\circ\text{C}/\text{W}$ )  
 6 Ld SC-70 ..... 200  
 Pb-free reflow profile ..... see link below  
<http://www.intersil.com/pbfree/Pb-FreeReflow.asp>

*CAUTION: Stresses above those listed in "Absolute Maximum Ratings" may cause permanent damage to the device. This is a stress only rating and operation of the device at these or any other conditions above those indicated in the operational sections of this specification is not implied.*

**IMPORTANT NOTE:** All parameters having Min/Max specifications are guaranteed. Typ values are for information purposes only.

**Electrical Specifications**  $V_{SP} = +5\text{V}$ ,  $Z_{RSC} = Z_{LOAD} = 50\Omega$ ,  $T_A = +25^\circ\text{C}$ ,  $24\Omega$   $V_{SP}$  to OUT, unless otherwise specified.

PARAMETER	DESCRIPTION	CONDITIONS	MIN	TYP	MAX	UNIT
Vsp	Supply Voltage	To operate below 5V, the $24\Omega$ resistor to supply should be reduced	3.0		5.5	V
Gt	Small Signal Gain	1.0GHz	17	18.3	19.5	dB
		1.5GHz	16.1	17.4	18.6	dB
		2.0GHz	15.1	16.6	17.6	dB
P1dB	Output Power at 1dB Compression	1.0GHz	16	17.7	19	dBm
		2.0GHz	15.9	17.2	18.9	dBm
OIP3	Output Third Order Intercept Point	1.0GHz		30		dBm
		2.0GHz		27		dBm
OIP2	Output Second Order Intercept Point	Input tones at 1.0GHz and 1.1GHz, at Input Power = $-15\text{dBm}$ , Output tone 2.1GHz		44.2		dBm
BW	3dB Bandwidth	3dB below Gain @ 500MHz		2.4		GHz
IRL	Input Return Loss	1.0GHz $Z_{RSC} = 75\Omega$ , $Z_{LOAD} = 50\Omega$		23.5		dB
ORL	Output Return Loss	1.0GHz $Z_{RSC} = 75\Omega$ , $Z_{LOAD} = 50\Omega$		21.8		dB
RISOL	Reverse Isolation	2.0GHz		22.4		dB
NF	Noise Figure	2.0GHz		4.7		dB
ID	Device Operating Current		56	63.5	71	mA

Device Test Setup

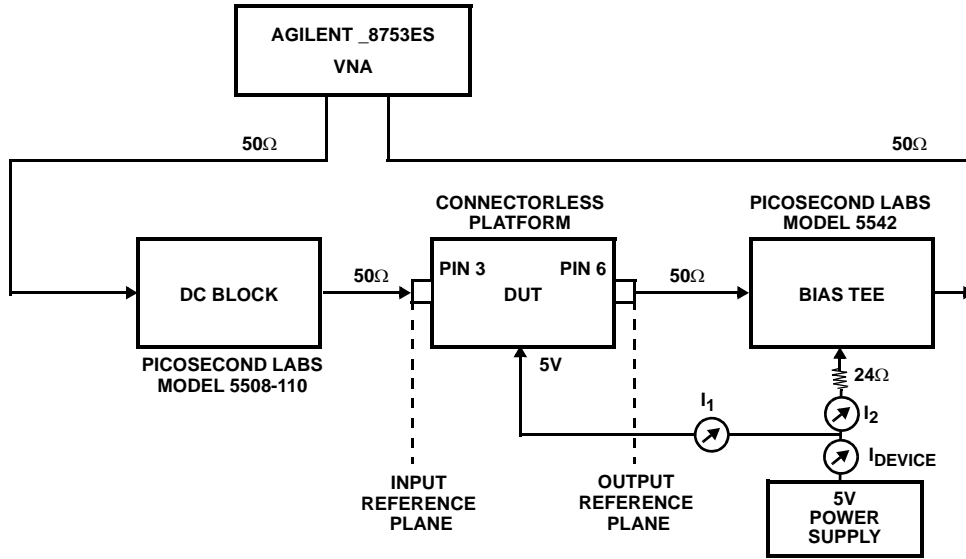

Typical Performance Curves  $Z_{src} = 75\Omega, Z_{load} = 50\Omega$

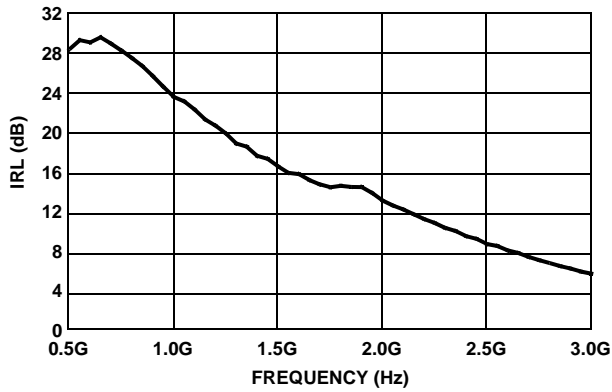

FIGURE 1. INPUT RETURN LOSS vs FREQUENCY

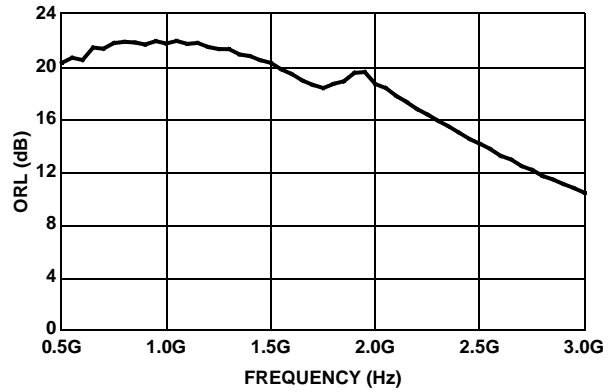

FIGURE 2. OUTPUT RETURN LOSS vs FREQUENCY

Typical Performance Curves 50Ω environment

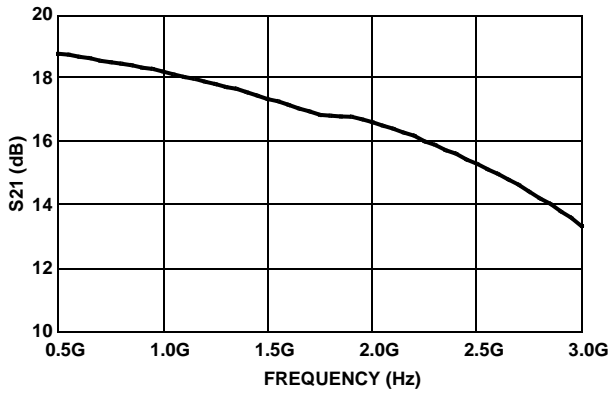

FIGURE 3. |S21| vs FREQUENCY

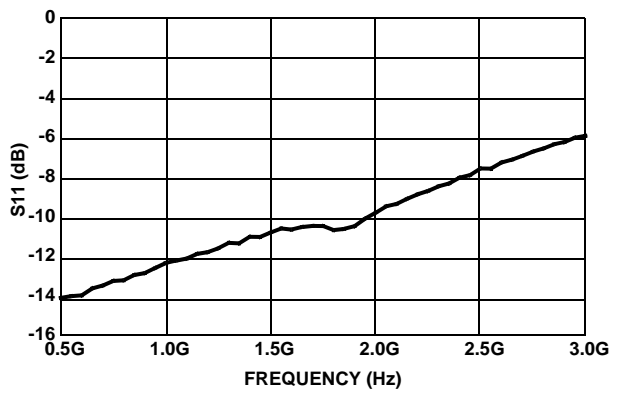

FIGURE 4. |S11| vs FREQUENCY

Typical Performance Curves 50Ω environment (Continued)

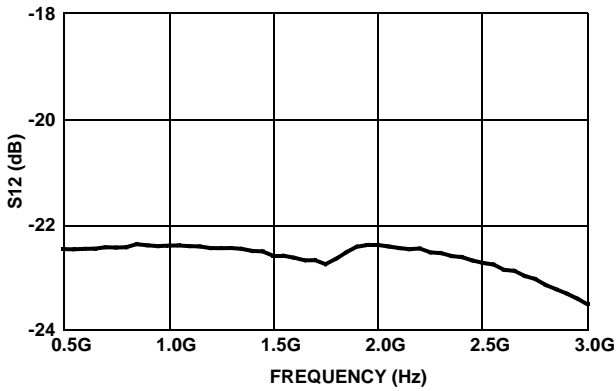

FIGURE 5. |S12| vs FREQUENCY

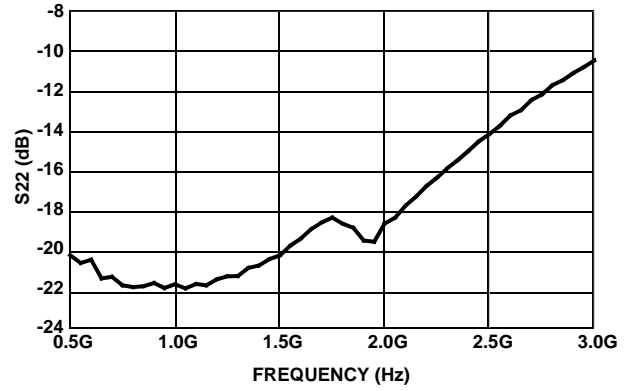

FIGURE 6. |S22| vs FREQUENCY

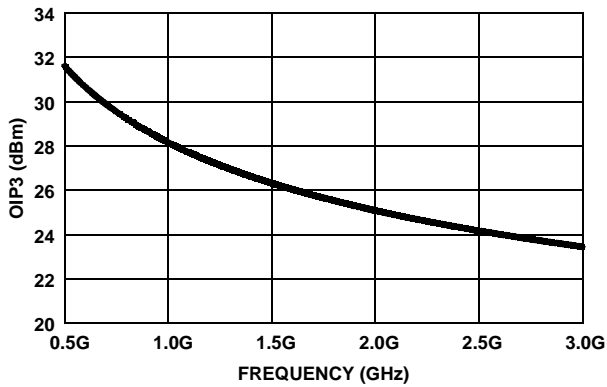

FIGURE 7. OIP3 vs FREQUENCY

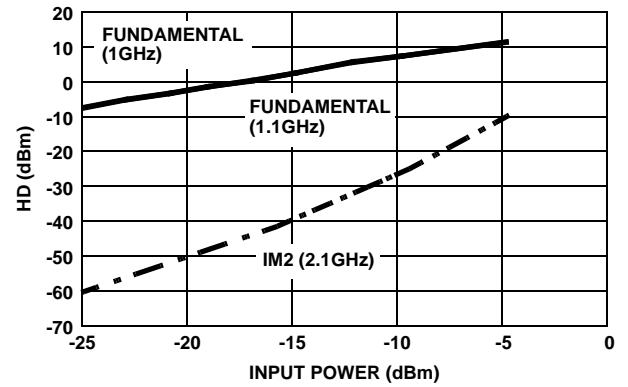

FIGURE 8. IM2 vs INPUT POWER

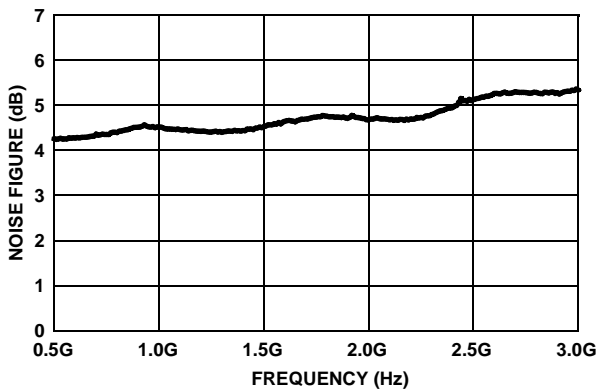

FIGURE 9. NOISE FIGURE vs FREQUENCY

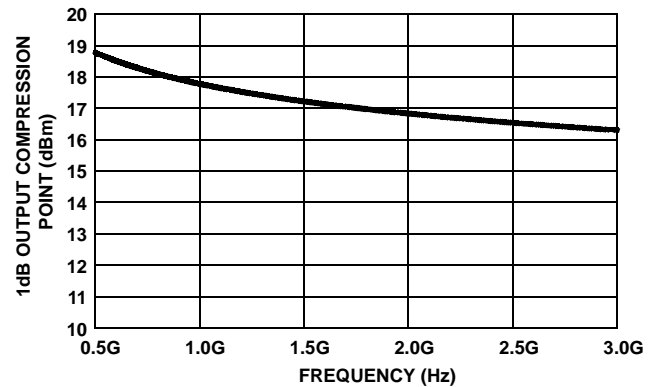

FIGURE 10. P1dB vs FREQUENCY

Typical Performance Curves 50Ω environment (Continued)

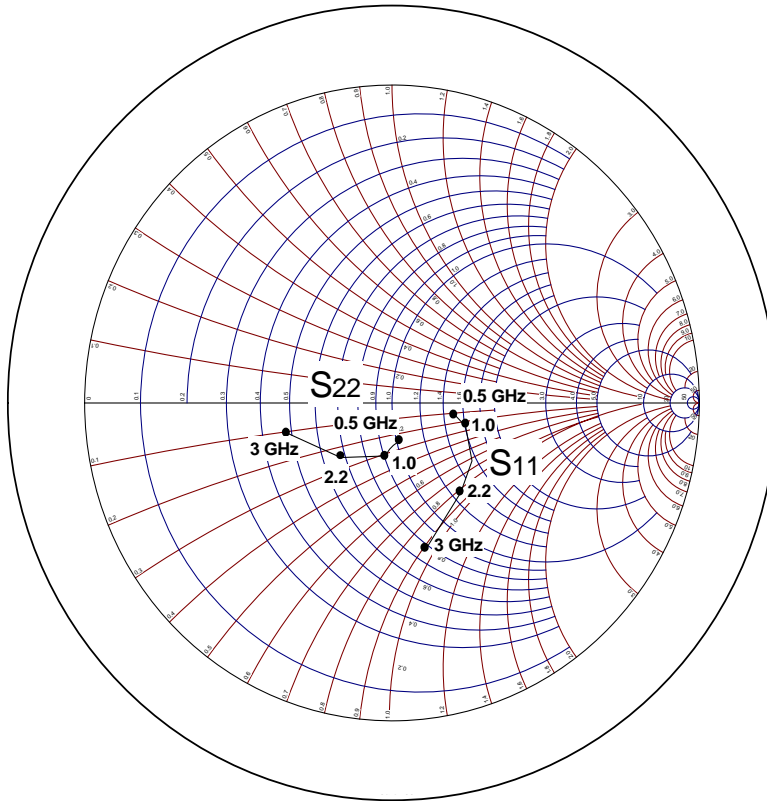
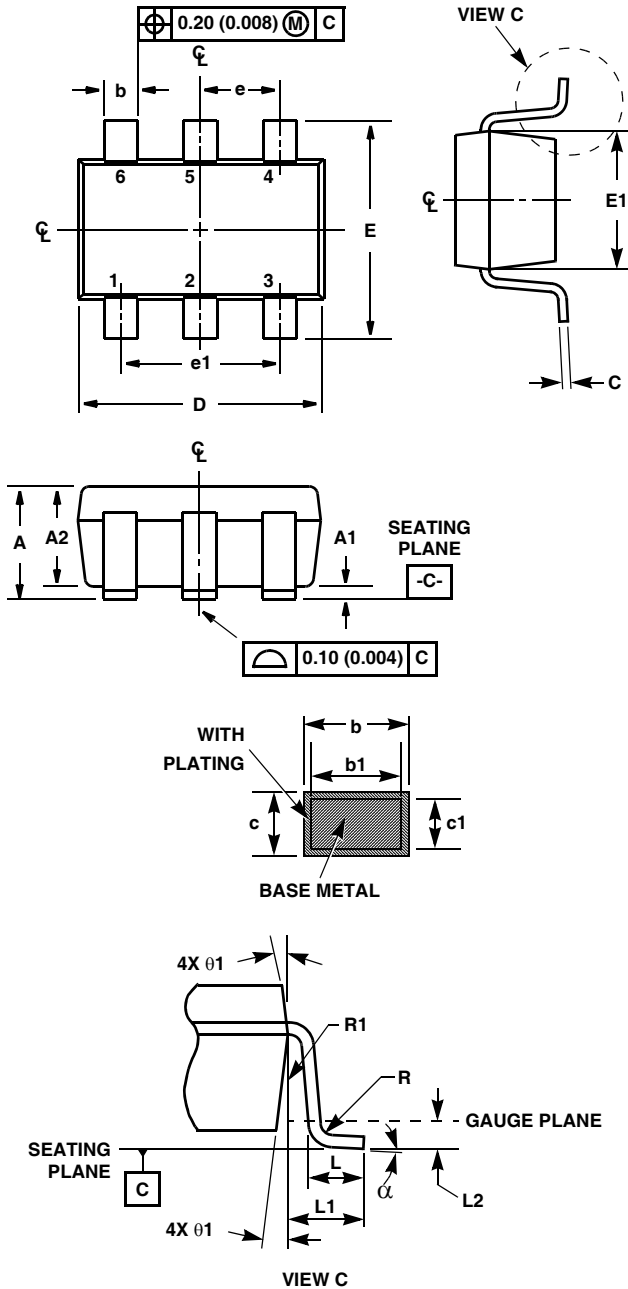

FIGURE 11. S11 AND S22 vs FREQUENCY

## Small Outline Transistor Plastic Packages (SC70-6)



### P6.049A

#### 6 LEAD SMALL OUTLINE TRANSISTOR PLASTIC PACKAGE

SYMBOL	INCHES		MILLIMETERS		NOTES
	MIN	MAX	MIN	MAX	
A	0.031	0.039	0.80	1.00	-
A1	0.001	0.004	0.025	0.10	-
A2	0.034	0.036	0.85	0.90	-
b	0.006	0.012	0.15	0.30	-
b1	0.006	0.010	0.15	0.25	-
c	0.004	0.008	0.10	0.20	6
c1	0.004	0.006	0.10	0.15	6
D	0.073	0.085	1.85	2.15	3
E	0.084 BSC		2.1 BSC		-
E1	0.045	0.053	1.15	1.35	3
e	0.0256 Ref		0.65 Ref		-
e1	0.0512 Ref		1.30 Ref		-
L	0.010	0.018	0.26	0.46	4
L1	0.016 Ref.		0.400 Ref.		-
L2	0.006 BSC		0.15 BSC		-
N	6		6		5
R	0.004	-	0.10	-	-
$\alpha$	0°	8°	0°	8°	-

Rev. 0 7/05

#### NOTES:

1. Dimensioning and tolerance per ASME Y14.5M-1994.
2. Package conforms to EIAJ SC70 and JEDEC MO203AB.
3. Dimensions D and E1 are exclusive of mold flash, protrusions, or gate burrs.
4. Footlength L measured at reference to gauge plane.
5. "N" is the number of terminal positions.
6. These Dimensions apply to the flat section of the lead between 0.08mm and 0.15mm from the lead tip.
7. Controlling dimension: MILLIMETER. Converted inch dimensions are for reference only.

All Intersil U.S. products are manufactured, assembled and tested utilizing ISO9000 quality systems.

Intersil Corporation's quality certifications can be viewed at [www.intersil.com/design/quality](http://www.intersil.com/design/quality)

*Intersil products are sold by description only. Intersil Corporation reserves the right to make changes in circuit design, software and/or specifications at any time without notice. Accordingly, the reader is cautioned to verify that data sheets are current before placing orders. Information furnished by Intersil is believed to be accurate and reliable. However, no responsibility is assumed by Intersil or its subsidiaries for its use; nor for any infringements of patents or other rights of third parties which may result from its use. No license is granted by implication or otherwise under any patent or patent rights of Intersil or its subsidiaries.*

For information regarding Intersil Corporation and its products, see [www.intersil.com](http://www.intersil.com)