



M I C R O T U N E ®

RF SILICON AND SUBSYSTEMS SOLUTIONS
FOR BROADBAND COMMUNICATIONS AND AUTOMOTIVE ELECTRONICS

MT2064 SINGLE-CHIP BROADBAND TUNER

PRODUCT BRIEF

The MT2064 is a low-power 3.3V single-chip broadband tuner with an integrated IF variable-gain amplifier.



MT2064 Single-Chip Broadband Tuner

The MicroTuner™ MT2064 is an advanced, low-power single-chip broadband tuner that has been optimized for high-performance cable modems and embedded multimedia terminal adapter (E-MTA) that require low composite distortion and low noise under digital cable environments.

The MT2064 is capable of receiving frequencies in the 48 MHz to 1 GHz range and of converting a selected channel to a standard intermediate frequency (IF) between 30 MHz and 60 MHz.

The MT2064's low phase noise makes it ideal for use in digital applications such as video, voice and high-speed data. Its dual-conversion architecture, with no requirement for tracking filters, yields the desirable characteristics of traditional cable television tuners: controlled input impedance across the entire input band, low in-band emissions, and outstanding image rejection.

In addition, the MT2064 provides excellent in-band flatness as well as very repeatable gain characteristics across the complete reception band.

The MT2064's low-power consumption significantly conserves current and can be effectively used to extend the operation of battery-powered E-MTA.

The MT2064 can be used in conjunction with MicroTune's upstream amplifiers to create a complete RF front end for bi-directional cable modem

APPLICATIONS

- VoIP Telephony Modems
- Cable Modems
- PacketCable™ E-MTA

FEATURES

- 48 MHz to 1000 MHz input frequency range
- 3.3V power supply
- Single-ended RF input reduces BOM by eliminating input balun
- Works seamlessly with all digital demodulators
- Low power dual-conversion architecture
- Minimal external components
- No tunable parts required
- Integrated IF variable gain amplifier for direct connection to digital demodulators
- Low phase noise for excellent performance in QAM 64 and QAM 256 systems
- Software and hardware shutdown modes
- Frequency synthesizers fully programmable via serial-control interface
- Fully integrated VCO circuitry simplifies PCB layout
- General-purpose input/ output (GPIO) controllable via serial-control interface
- Intermediate frequency (IF) output fully compatible with DOCSIS® 2.0, EuroDOCSIS™ 2.0
- Integrated temperature sensor
- Operates with a 16 MHz crystal
- Small 6 mm x 6 mm 40-pin Quad Flat No-Lead (QFN) package

PRELIMINARY

M I C R O T U N E

RECOMMENDED OPERATING CONDITIONS

PARAMETER	MIN	TYP	MAX	UNIT
Supply voltage	3.15	3.3	3.45	V
Supply voltage ripple			25	mVp-p
Operating junction temperature			125	°C
Serial control clock			400	kHz

ABSOLUTE MAXIMUM RATINGS

PARAMETER	MIN	MAX	UNIT
Supply voltage		3.6	V
Storage temperature range	-40	150	°C
Lead-free temperature (soldering 5 seconds)		260	°C
Input voltage	-0.3	VCC +0.3	V

TUNER ELECTRICAL CHARACTERISTICS

PARAMETER	MIN	TYP	MAX	UNIT
Power supply				
Active current		242		mA
RF signal path				
Input frequency range	48		1000	MHz
Second intermediate frequency (programmable)	30		60	MHz
Noise figure		9.5		dB
RF gain range		33		dB
Image rejection		65		dBc
Phase noise (10 kHz)		-84		dBc/Hz
Phase noise (100 kHz)		-106		dBc/Hz
IF Variable Gain Amplifier (VGA)				
Output voltage		2.0		Vp-p
AGC range		37		dB

SECOND IF SAW ELECTRICAL CHARACTERISTICS

PARAMETER	MIN	TYP	MAX	UNIT
Second IF SAW loss			17	dB

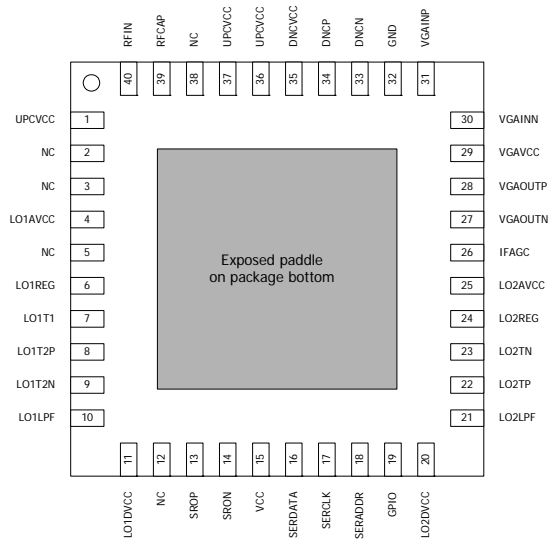

MT2064 Pin Diagram

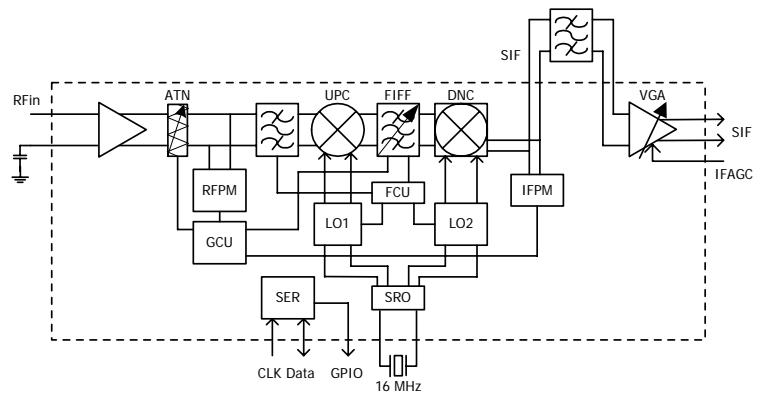

MT2064 Block Diagram

PRELIMINARY



MicroTune, Inc., 2201 Tenth Street, Plano, TX 75074, USA

Tel: +1-972-673-1600, Fax: +1-972-673-1602, E-mail: sales@microtune.com, Web site: www.microtune.com

For a detailed list of office locations, sales offices, and sales representatives, visit our Web site at www.microtune.com

The information in this document is believed to be accurate and reliable. MicroTune assumes no responsibility for any consequences arising from the use of this information, nor from any infringement of patents or the rights of third parties which may result from its use. No license is granted by implication or otherwise under any patent or other rights of MicroTune. The information in this publication replaces and supersedes all information previously supplied, and is subject to change without notice. The customer is responsible for assuring that proper design and operating safeguards are observed to minimize inherent and procedural hazards. MicroTune assumes no responsibility for applications assistance or customer product design.

The devices described in this document are not authorized for use in medical, life-support equipment, or any other application involving a potential risk of severe property or environmental damage, personal injury, or death without prior express written approval of MicroTune. Any such use is understood to be entirely at the user's risk.

MicroTune is a registered trademark of MicroTune, Inc. MicroTuner, MicroStreamer, VideoCaster, DataCaster, ClearTune, and the MicroTune logo are trademarks of MicroTune, Inc. All other trademarks belong to their respective companies.

MicroTune's products are protected by one or more of the following U.S. patents: 5,625,325; 5,648,744; 5,717,730; 5,737,035; 5,739,730; 5,805,988; 5,847,612; 6,100,761; 6,104,242; 6,163,684; 6,169,569; 6,172,378; 6,177,964; 6,211,745; 6,218,899; 6,268,778; 6,310,387; 6,323,736; 6,355,537; 6,429,502; 6,462,327; 6,535,068; 6,580,313; 6,608,522; 6,631,257; 6,714,776; 6,725,463; 6,744,308; 6,771,124; 6,784,945; 6,804,099; 6,888,406; 6,891,435; 6,906,594; 6,909,886; 6,919,774; 6,920,182; 6,922,556; 6,963,478; 6,973,288; 6,993,310; 7,035,614; 7,078,960; 7,079,195; 7,164,899; 7,171,176; 7,184,724; D469,742 and additional patents pending or filed.