

PWM Controlled, PWM/PFM Switchable Step-up DC/DC Controllers

☆GO-Compatible

■ GENERAL DESCRIPTION

The XC6367/68 series are multi-functional step-up DC/DC converter controllers with built-in high speed, low ON resistance drivers.

High efficiency is possible using an externally connected transistor, coil, diode and capacitor.

Output voltage is selectable in 100mV increments within a range of 1.5V ~ 6.5V ($\pm 2.5\%$). For output voltages outside this range, we recommend FB version, which has a 1.0V internal reference voltage. Using the FB version, the required output voltage can be set-up using 2 external resistors.

With a 300kHz oscillation frequency, the size of the external components can be reduced.

Control switches from PWM to PFM during light loads with the XC6368 (PWM/PFM switchable) and the series is highly efficient from light loads to large output currents.

Soft start time of XC6367/68A, B, and E series is internally set to 10msec and XC6367/68C, D, and F series regulate soft-start time by connecting resistors and capacitors externally.

During stand-by (CE pin "Low"), supply current is reduced to less than $0.5 \mu\text{A}$.

■ APPLICATIONS

- Electronic information organizers
- Palmtops
- Cellular and portable phones
- Portable audio systems
- Various multi-function power supplies

■ FEATURES

- Input Voltage Range** : 0.9V ~ 10V
- Operating Voltage Range** : 2.0V ~ 10V
- Output voltage Range** : 1.5V ~ 6.5V programmable in 100mV increments ($\pm 2.5\%$)
- Oscillation Frequency** : 300kHz, 100kHz ($\pm 15\%$)
Custom products for 180kHz, 500kHz
- Output Current** : More than 200mA
($V_{IN}=1.8\text{V}$, $V_{OUT}=3.3\text{V}$)
- High Efficiency** : 84% (TYP.)
- Stand-by capability** : $ISTB=0.5 \mu\text{A}$ (MAX.)
- Selection** : Soft-start set-up external
Output voltage set-up internal (V_{OUT})
Output voltage set-up external (FB)
- PWM/PFM Switching Control (XC6368)**
- Package** : SOT-25

■ TYPICAL APPLICATION CIRCUIT

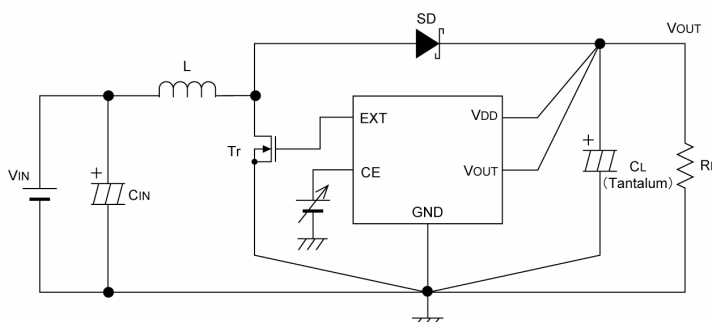

■ TYPICAL PERFORMANCE CHARACTERISTICS

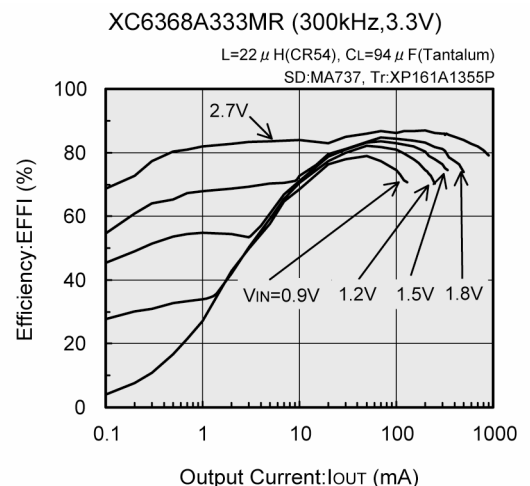

PIN CONFIGURATION

XC6367/XC6368 series

A, B, C, D types

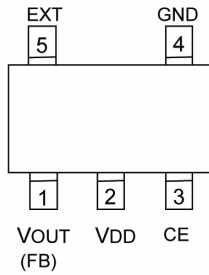

SOT-25
(TOP VIEW)

XC6367/XC6368 series

E, F types

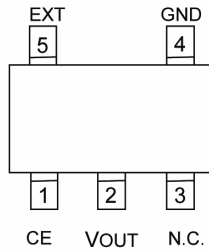

SOT-25
(TOP VIEW)

PIN ASSIGNMENT

PIN NUMBER		PIN NAME	FUNCTION
XC6367/XC6368			
A, B, C, D	E, F		
5	5	EXT	: External Transistor Connection
2	-	VDD	: Supply Voltage Input
4	4	GND	: Ground
3	1	CE	: Chip Enable (C, D, F Types: Soft Start External Set-Up, Soft Start Capacitor Connected)
1	2	VOUT (FB)	: Output Voltage Monitor (E, F Types: Output Voltage Monitor, Power Supply) (B, D Types: Output Voltage External Set-up)

PRODUCT CLASSIFICATION

● Selection Guide

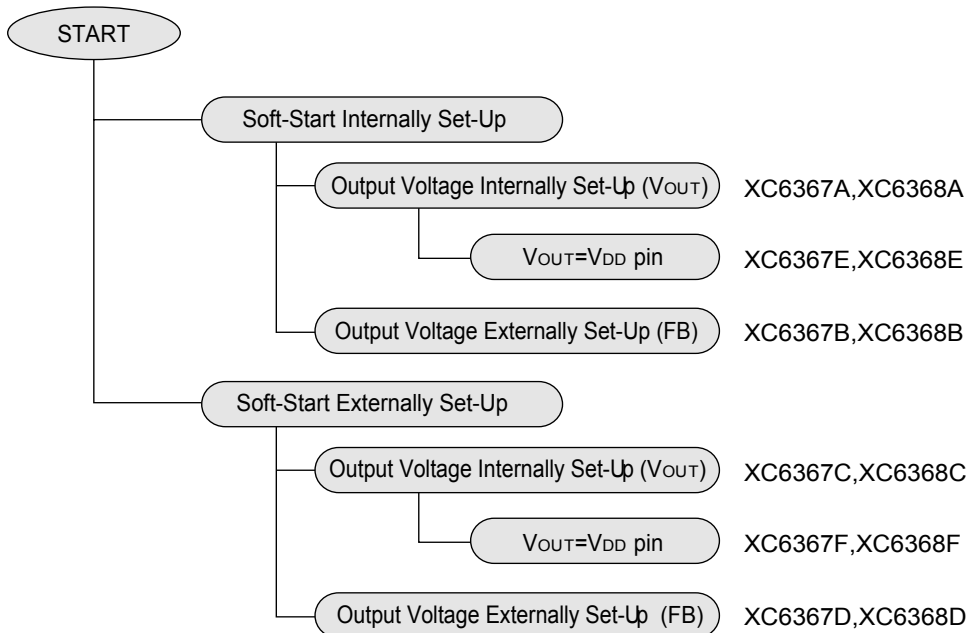

■ PRODUCT CLASSIFICATION (Continued)

● Ordering Information

XC6367①②③④⑤⑥ PWM Control

XC6368①②③④⑤⑥ PWM/PFM Switching Control

DESIGNATOR	DESCRIPTION	SYMBOL	DESCRIPTION
①	Type of DC/DC Converter	A	: VOUT type: VOUT internally set-up, Soft-start internally set-up
		B	: FB type: VOUT externally set-up, Soft-start internally set-up
		C	: VOUT type: VOUT internally set-up, Soft-start externally set-up
		D	: FB type: VOUT externally set-up, Soft-start externally set-up
		E	: VOUT type: VOUT internally set-up, Soft-start internally set-up
		F	: VOUT type: VOUT internally set-up, Soft-start externally set-up
② ③	Output Voltage	15 ~ 65	: VOUT type: 3.0V output → ②=3, ③=0
		10	: FB type (B, D types): 10 fixed → ②=1, ③=0 fixed
④	Oscillation Frequency	3	: 300kHz
		1	: 100kHz
		2	: 180kHz (Custom)
		5	: 500kHz (Custom)
⑤	Package	M	: SOT-25 (SOT-23-5)
⑥	Device Orientation	R	: Embossed tape, standard feed
		L	: Embossed tape, reverse feed

■ BLOCK DIAGRAMS

XC6367, XC6368 Series A, C, E, F types (V_{OUT})

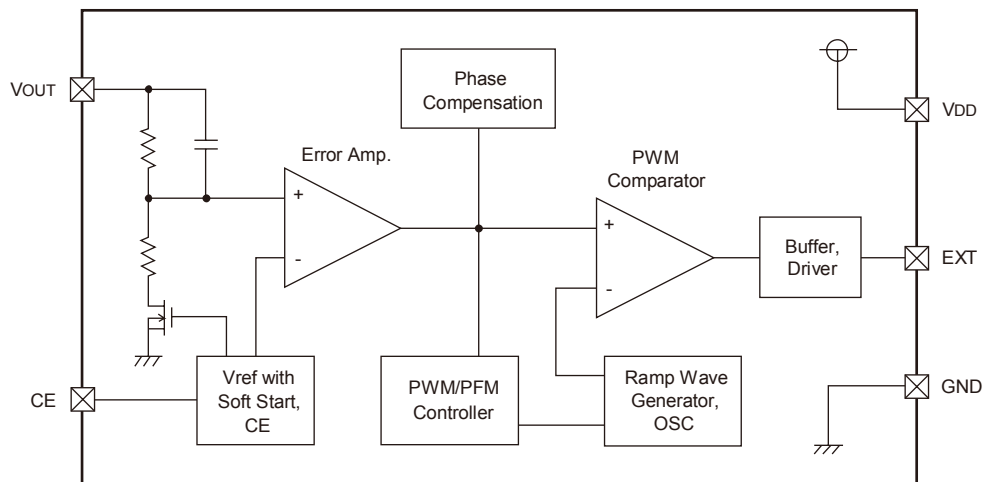

* V_{OUT} and V_{DD} of the E and F types should be connected internally.

XC6367, XC6368 Series B, D types (FB)

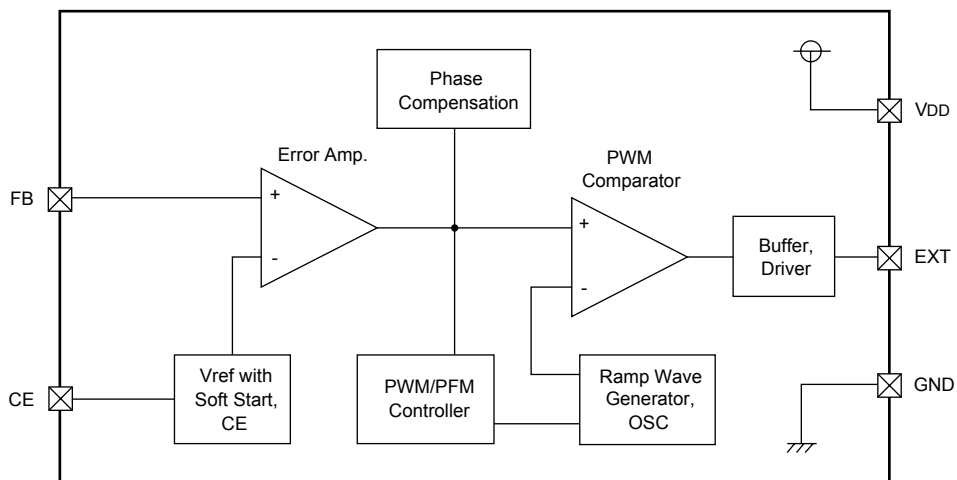

■ ABSOLUTE MAXIMUM RATINGS

Ta = 25°C

PARAMETER	SYMBOL	RATINGS	UNITS
VDD Pin Voltage	VDD	-0.3 ~ +12.0	V
VOUT Pin Voltage	VOUT	-0.3 ~ +12.0	V
FB Pin Voltage	VFB	-0.3 ~ +12.0	V
CE Pin Voltage	VCE	-0.3 ~ +12.0	V
EXT Pin Voltage	VEXT	-0.3 ~ VDD+0.3	V
EXT Pin Current	IEXT	±100	mA
Power Dissipation	Pd	150	mW
Operating Temperature Range	Topr	-30 ~ +80	°C
Storage Temperature Range	Tstg	-40 ~ +125	°C

*Voltage is all ground standardized.

■ ELECTRICAL CHARACTERISTICS

XC6367A333MR, XC6368A333MR

VOUT=3.3V, FOSC=300kHz, Ta=25°C

PARAMETER	SYMBOL	CONDITIONS	MIN.	TYP.	MAX.	UNITS
Output Voltage	VOUT		3.218	3.300	3.383	V
Supply Voltage (* 1)	VDD		2.0	-	10.0	V
Maximum Input Voltage	VIN		10.0	-	-	V
Oscillation Start Voltage 1	VST1	Tr: 2SD1628, IOUT=1.0mA	-	-	0.9	V
Oscillation Start Voltage 2	VST2	VOUT=CE: Apply voltage	-	-	0.8	V
Oscillation Hold Voltage	VHLD	Tr: Use of a 2SX1628, IOUT=1.0mA	-	-	0.7	V
Supply Current 1	IDD1	VOUT=CE=setting output voltage x 0.95	-	130	200	μA
Supply Current 2	IDD2	VOUT=CE=setting output voltage + 0.5V	-	20	35	μA
Stand-by Current	ISTB	VOUT=setting output voltage x 0.95, CE=0V	-	-	0.5	μA
Oscillator Frequency	FOSC	Same as IDD1	255	300	345	kHz
Maximum Duty Ratio	MAXDTY	Same as IDD1	78	85	92	%
PFM Duty Ratio (* 3)	PFMDTY	IOUT=0mA	15	25	35	%
CE "High" Voltage	VCEH	VOUT=setting output voltage x0.95	0.65	-	-	V
CE "Low" Voltage	VCEL	VOUT=setting output voltage x0.95	-	-	0.20	V
EXT "High" ON Resistance	REXTH	Same as IDD1, VEXT=VOUT-0.4V	-	29	43	Ω
EXT "Low" ON Resistance	REXTL	Same as IDD1, VEXT=0.4V	-	19	27	Ω
Efficiency (* 2)	EFFI		-	84	-	%
Soft-Start Time	TSS		5	10	20	msec

Conditions: Unless otherwise stated, connect VDD to VOUT; VIN=setting output voltage x 0.6, IOUT=130mA
NOTE:

* 1: When taking VDD from another power source please ensure that VDD = 2.0V or more.
Oscillation will occur with a value of VDD = 0.8V or more, but with a value of VDD = 2.0V or more, output voltage and oscillation frequency will be stable.

* 2: $EFFI = \frac{[(\text{output voltage}) \times (\text{output current})]}{[(\text{input voltage}) \times (\text{input current})]} \times 100$

* 3: Applies to the XC6368 series only (duty ratio when control changes to PFM).

■ ELECTRICAL CHARACTERISTICS (Continued)

XC6367A503MR, XC6368A503MR

V_{OUT}=5.0V, F_{OSC}=300kHz, T_a=25°C

PARAMETER	SYMBOL	CONDITIONS	MIN.	TYP.	MAX.	UNITS
Output Voltage	V _{OUT}		4875	5.000	5.125	V
Supply Voltage (* 1)	V _{DD}		2.0	-	10.0	V
Maximum Input Voltage	V _{IN}		10.0	-	-	V
Oscillation Start Voltage 1	V _{ST1}	Tr: 2SD1628, I _{OUT} =1.0mA	-	-	0.9	V
Oscillation Start Voltage 2	V _{ST2}	V _{OUT} =CE : Apply voltage	-	-	0.8	V
Oscillation Hold Voltage	V _{HLD}	Tr: 2SD1628, I _{OUT} =1.0mA	-	-	0.7	V
Supply Current 1	I _{DD1}	V _{OUT} =CE=setting output voltage x 0.95	-	180	280	μA
Supply Current 2	I _{DD2}	V _{OUT} =CE=setting output voltage + 0.5V	-	22	38	μA
Stand-by Current	I _{STB}	V _{OUT} =setting output voltage x 0.95, CE=0V	-	-	0.5	μA
Oscillation Frequency	F _{OSC}	Same as I _{DD1}	255	300	345	kHz
Maximum Duty Ratio	MAXDTY	Same as I _{DD1}	78	85	92	%
PFM Duty Ratio (* 3)	PFMDTY	I _{OUT} =0mA	15	25	35	%
CE "High" Voltage	V _{CEH}	V _{OUT} =setting output voltage x0.95	0.65	-	-	V
CE "Low" Voltage	V _{CEL}	V _{OUT} =setting output voltage x0.95	-	-	0.20	V
EXT "High" ON Resistance	R _{EXTH}	Same as I _{DD1} , V _{EXT} =V _{OUT} -0.4V	-	20	29	Ω
EXT "Low" ON Resistance	R _{EXTL}	Same as I _{DD1} , V _{EXT} =0.4V	-	13	19	Ω
Efficiency (* 2)	EFFI		-	87	-	%
Soft-Start Time	T _{SS}	Connect R _{SS} and C _{SS} , CE:0V→3.0V (XC6367C/F and XC6368C/F series)	5	10	20	msec

Conditions: Unless otherwise specified, connect V_{DD} to V_{OUT}; V_{IN}=setting output voltage x 0.6, I_{OUT}=200mA
NOTE:

- * 1: When taking V_{DD} from another power source please ensure that V_{DD} = 2.0V or more.
Oscillation will occur with a value of V_{DD} = 0.8V or more, but with a value of V_{DD} = 2.0V or more, output voltage and oscillation frequency will be stable.
- * 2: $EFFI = \frac{[(\text{output voltage}) \times (\text{output current})]}{[(\text{input voltage}) \times (\text{input current})]} \times 100$
- * 3: Applies to the XC6368 series only (duty ratio when control changes to PFM).
- * 4: The values of supply voltage and NOTE *1 do not apply to XC6367E/F and XC6368E/F series. For XC6367E/F and XC6368E/F series, output voltage less than 2.0V cannot be set-up.

■ ELECTRICAL CHARACTERISTICS (Continued)

XC6367B103MR, XC6368B103MR

V_{OUT}=3.0V, F_{OSC}=300kHz, T_a=25°C

PARAMETER	SYMBOL	CONDITIONS	MIN.	TYP.	MAX.	UNITS
Output Voltage	V _{OUT}		2.925	3.000	3.075	V
Supply Voltage (* 1)	V _{DD}		2.0	-	10.0	V
Maximum Input Voltage	V _{IN}		10.0	-	-	V
Oscillation Start Voltage 1	V _{ST1}	Tr: 2SD1628, I _{OUT} =1.0mA	-	-	0.9	V
Oscillation Start Voltage 2	V _{ST2}	V _{DD} =CE: Apply voltage, FB=0V	-	-	0.8	V
Oscillation Hold Voltage	V _{HLD}	Tr: 2SD1628, I _{OUT} =1.0mA	-	-	0.7	V
Supply Current 1	I _{DD1}	V _{DD} =CE=2.85V, FB=0V	-	120	190	μA
Supply Current 2	I _{DD2}	V _{DD} =CE=3.5V, FB=1.2V	-	20	34	μA
Stand-by Current	I _{STB}	V _{DD} =2.85V, CE=0V, FB=0V	-	-	0.5	μA
Oscillation Frequency	F _{OSC}	Same as I _{DD1}	255	300	345	kHz
Maximum Duty Ratio	MAXDTY	Same as I _{DD1}	78	85	92	%
PFM Duty Ratio (* 3)	PFMDTY	I _{OUT} =0mA	15	25	35	%
CE "High" Voltage	V _{CEH}	V _{DD} =2.85V, FB=0V	0.65	-	-	V
CE "Low" Voltage	V _{CEL}	V _{DD} =2.85V, FB=0V	-	-	0.20	V
EXT "High" ON Resistance	R _{EXTH}	Same as I _{DD1} , V _{EXT} =V _{DD} -0.4V	-	32	47	Ω
EXT "Low" ON Resistance	R _{EXTL}	Same as I _{DD1} , V _{EXT} =0.4V	-	20	30	Ω
Efficiency (* 2)	EFFI		-	84	-	%
Soft-Start Time	T _{SS}	Connect R _{SS} and C _{SS} , CE:0V→3.0V (XC6367D/68D series)	5	10	20	msec

Conditions: Unless otherwise stated, V_{IN}=1.8V, I_{OUT}=120mA

External components : R_{FB1} = 400kΩ, R_{FB2} = 200kΩ, C_{FB} = 47pF

NOTE:

* 1: When taking V_{DD} from another power source please ensure that V_{DD} = 2.0V or more.

Oscillation will occur with a value of V_{DD} = 0.8V or more, but with a value of V_{DD} = 2.0V or more, output voltage and oscillation frequency will be stable.

* 2: EFFI = $\frac{[(\text{output voltage}) \times (\text{output current})]}{[(\text{input voltage}) \times (\text{input current})]} \times 100$

* 3: Applies to the XC6368 series only (duty ratio when control changes to PFM).

■ ELECTRICAL CHARACTERISTICS (Continued)

XC6367A331MR, XC6368A331MR

V_{OUT}=3.3V, F_{OSC}=100kHz, T_a=25°C

PARAMETER	SYMBOL	CONDITIONS	MIN.	TYP.	MAX.	UNITS
Output Voltage	V _{OUT}		3.218	3.300	3.383	V
Supply Voltage (* 1)	V _{DD}		2.0	-	10.0	V
Maximum Input Voltage	V _{IN}		10.0	-	-	V
Oscillation Start Voltage 1	V _{ST1}	Tr: 2SD1628, I _{OUT} =1.0mA	-	-	0.9	V
Oscillation Start Voltage 2	V _{ST2}	V _{OUT} =CE: Apply voltage	-	-	0.8	V
Oscillation Hold Voltage	V _{HLD}	Tr: 2SD1628, I _{OUT} =1.0mA	-	-	0.7	V
Supply Current 1	I _{DD1}	V _{OUT} =CE=setting output voltage x 0.95	-	50	100	μA
Supply Current 2	I _{DD2}	V _{OUT} =CE=setting output voltage + 0.5V	-	11	20	μA
Stand-by Current	I _{STB}	V _{OUT} =setting output voltage x 0.95, CE=0V	-	-	0.5	μA
Oscillation Frequency	F _{OSC}	Same as I _{DD1}	85	100	115	kHz
Maximum Duty Ratio	MAXDTY	Same as I _{DD1}	78	85	92	%
PFM Duty Ratio (* 3)	PFMDTY	I _{OUT} =0mA	15	25	35	%
CE "High" Voltage	V _{CEH}	V _{OUT} =setting output voltage x0.95	0.65	-	-	V
CE "Low" Voltage	V _{CEL}	V _{OUT} =setting output voltage x0.95	-	-	0.20	V
EXT "High" ON Resistance	R _{EXTH}	Same as I _{DD1} , V _{EXT} =V _{OUT} -0.4V	-	29	43	Ω
EXT "Low" ON Resistance	R _{EXTL}	Same as I _{DD1} , V _{EXT} =0.4V	-	19	27	Ω
Efficiency (* 2)	EFFI		-	84	-	%
Soft-Start Time	T _{SS}		5	10	20	msec

Conditions: Unless otherwise stated, connect V_{DD} to V_{OUT}; V_{IN}=setting output voltage x 0.6, I_{OUT}=130mA

NOTE:

- * 1: When taking V_{DD} from another power source please ensure that V_{DD} = 2.0V or more.
Oscillation will occur with a value of V_{DD} = 0.8V or more, but with a value of V_{DD} = 2.0V or more, output voltage and oscillation frequency will be stable.
- * 2: EFFI = $\frac{[(\text{output voltage}) \times (\text{output current})]}{[(\text{input voltage}) \times (\text{input current})]} \times 100$
- * 3: Applies to the XC6368 series only (duty ratio when control changes to PFM).

■ ELECTRICAL CHARACTERISTICS (Continued)

XC6367A501MR, XC6368A501MR

V_{OUT}=5.0V, F_{OSC}=100kHz, T_a=25°C

PARAMETER	SYMBOL	CONDITIONS	MIN.	TYP.	MAX.	UNITS
Output Voltage	V _{OUT}		4875	5.000	5.125	V
Supply Voltage (* 1)	V _{DD}		2.0	-	10.0	V
Maximum Input Voltage	V _{IN}		10.0	-	-	V
Oscillation Start Voltage 1	V _{ST1}	Tr: 2SD1628, I _{OUT} =1.0mA	-	-	0.9	V
Oscillation Start Voltage 2	V _{ST2}	V _{OUT} =CE: Apply voltage	-	-	0.8	V
Oscillation Hold Voltage	V _{HLD}	Tr: 2SX1628, I _{OUT} =1.0mA	-	-	0.7	V
Supply Current 1	I _{DD1}	V _{OUT} =CE=setting output voltage x 0.95	-	70	120	μA
Supply Current 2	I _{DD2}	V _{OUT} =CE=setting output voltage + 0.5V	-	11	22	μA
Stand-by Current	I _{STB}	V _{OUT} =setting output voltage x 0.95, CE=0V	-	-	0.5	μA
Oscillation Frequency	F _{OSC}	Same as I _{DD1}	85	100	115	kHz
Maximum Duty Ratio	MAXDTY	Same as I _{DD1}	78	85	92	%
PFM Duty Ratio (* 3)	PFMDTY	I _{OUT} =0mA	15	25	35	%
CE "High" Voltage	V _{CEH}	V _{OUT} =setting output voltage x0.95	0.65	-	-	V
CE "Low" Voltage	V _{CEL}	V _{OUT} =setting output voltage x0.95	-	-	0.20	V
EXT "High" ON Resistance	R _{EXTH}	Same as I _{DD1} , V _{EXT} =V _{OUT} -0.4V	-	20	29	Ω
EXT "Low" ON Resistance	R _{EXTL}	Same as I _{DD1} , V _{EXT} =0.4V	-	13	19	Ω
Efficiency (* 2)	EFFI		-	87	-	%
Soft-Start Time	T _{SS}		5	10	20	msec

Conditions: Unless otherwise stated, connect V_{DD} to V_{OUT}; V_{IN}=setting output voltage x 0.6, I_{OUT}=200mA
NOTE:

* 1: When taking V_{DD} from another power source please ensure that V_{DD} = 2.0V or more.
Oscillation will occur with a value of V_{DD} = 0.8V or more, but with a value of V_{DD} = 2.0V or more,
output voltage and oscillation frequency will be stable.

* 2: EFFI = $\frac{\text{[(output voltage) x (output current)]}}{\text{[(input voltage) x (input current)]}} \times 100$

* 3: Applies to the XC6368 series only (duty ratio when control changes to PFM).

■ ELECTRICAL CHARACTERISTICS (Continued)

XC6367B101MR, XC6368B101MR

V_{OUT}=3.0V, FOSC=100kHz, T_a=25°C

PARAMETER	SYMBOL	CONDITIONS	MIN.	TYP.	MAX.	UNITS
Output Voltage	V _{OUT}		2.925	3.000	3.075	V
Supply Voltage (* 1)	V _{DD}		2.0	-	10.0	V
Maximum Input Voltage	V _{IN}		10.0	-	-	V
Oscillation Start Voltage 1	V _{ST1}	Tr: 2SD1628, I _{OUT} =1.0mA	-	-	0.9	V
Oscillation Start Voltage 2	V _{ST2}	V _{DD} =CE: Apply voltage, FB=0V	-	-	0.8	V
Oscillation Hold Voltage	V _{HLD}	Tr: 2SD1628, I _{OUT} =1.0mA	-	-	0.7	V
Supply Current 1	I _{DD1}	V _{DD} =CE=2.85V, FB=0V	-	50	90	μA
Supply Current 2	I _{DD2}	V _{DD} =CE=3.5V, FB=1.2V	-	11	20	μA
Stand-by Current	I _{STB}	V _{DD} =2.85V, CE=0V, FB=0V	-	-	0.5	μA
Oscillation Frequency	FOSC	Same as I _{DD1}	85	100	115	kHz
Maximum Duty Ratio	MAXDTY	Same as I _{DD1}	78	85	92	%
PFM Duty Ratio (*3)	PFMDTY	I _{OUT} =0mA	15	25	35	%
CE "High" Voltage	V _{CEH}	V _{DD} =2.85V,FB=0V	0.65	-	-	V
CE "Low" Voltage	V _{CEL}	V _{DD} =2.85V,FB=0V	-	-	0.20	V
EXT "High" ON Resistance	R _{EXTH}	Same as I _{DD1} , V _{EXT} =V _{DD} -0.4V	-	32	47	Ω
EXT "Low" ON Resistance	R _{EXTL}	Same as I _{DD1} , V _{EXT} =0.4V	-	20	30	Ω
Efficiency (* 2)	EFFI		-	84	-	%
Soft-Start Time	T _{SS}		5	10	20	msec

Conditions: Unless otherwise stated, V_{IN}=1.8V, I_{OUT}=120mA

External components : R_{FB1} = 400kΩ, R_{FB2} = 200kΩ, C_{FB} = 47pF

NOTE:

- * 1: When taking V_{DD} from another power source please ensure that V_{DD} = 2.0V or more.
Oscillation will occur with a value of V_{DD} = 0.8V or more, but with a value of V_{DD} = 2.0V or more, output voltage and oscillation frequency will be stable.
- * 2: EFFI = $\frac{[(\text{output voltage}) \times (\text{output current})]}{[(\text{input voltage}) \times (\text{input current})]} \times 100$
- * 3: Applies to the XC6368 series only (duty ratio when control changes to PFM).

■ TEST CIRCUITS

Circuit 1. XC6367A, XC6368A

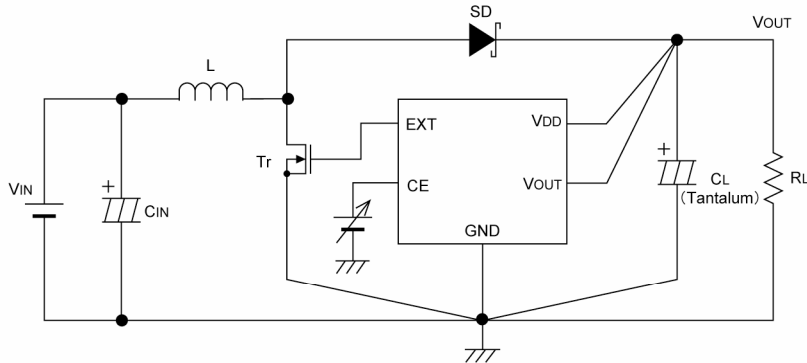

Circuit 2. XC6367B, XC6368B

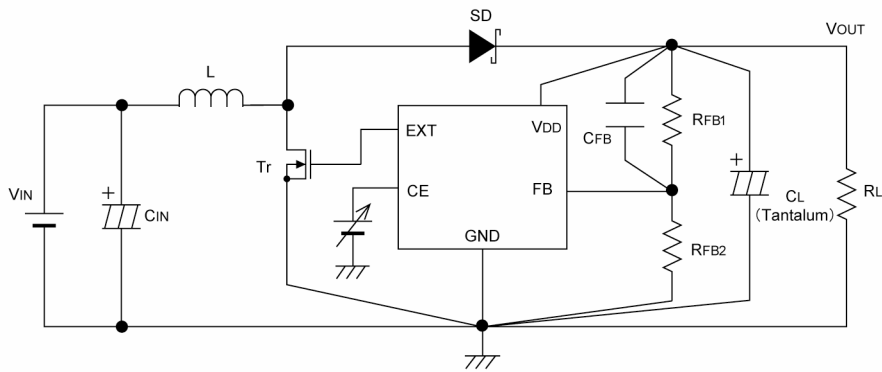

Circuit 3. XC6367C, XC6368C

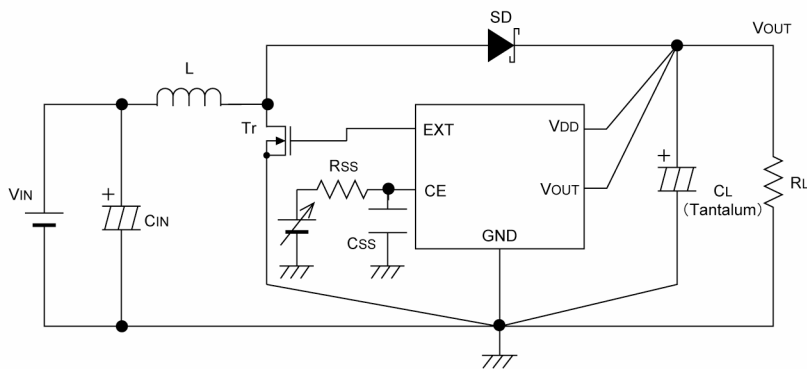

TEST CIRCUITS (Continued)

Circuit 4. XC6367D, XC6368D

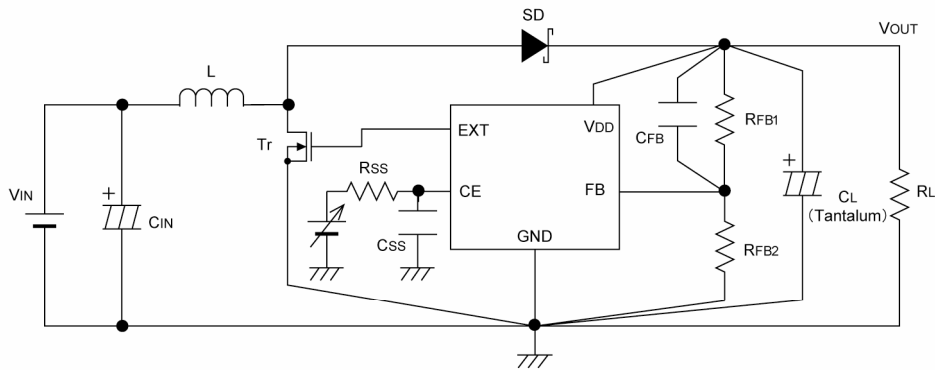

Circuit 5. XC6367E, XC6368E

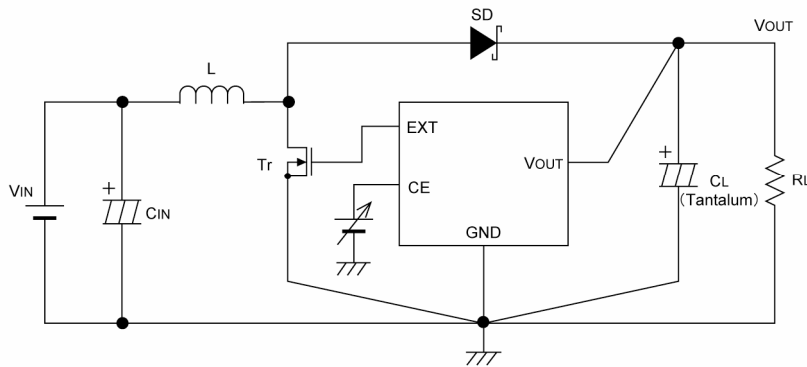

Circuit 6. XC6367F, XC6368F

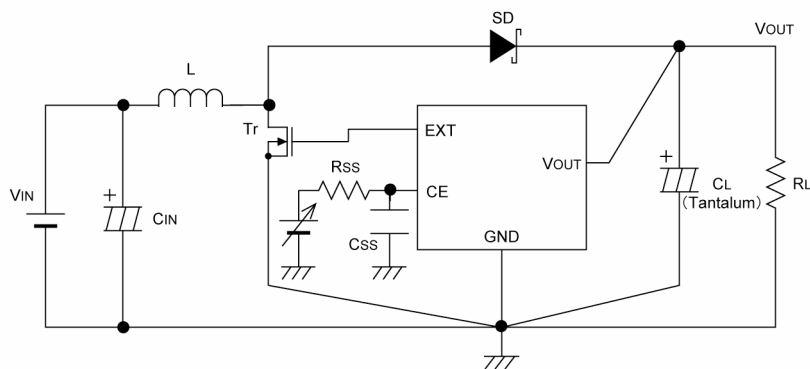

■ **TEST CIRCUITS (Continued)**

Circuit 7. XC6367A, XC6368A (NPN Transistor)

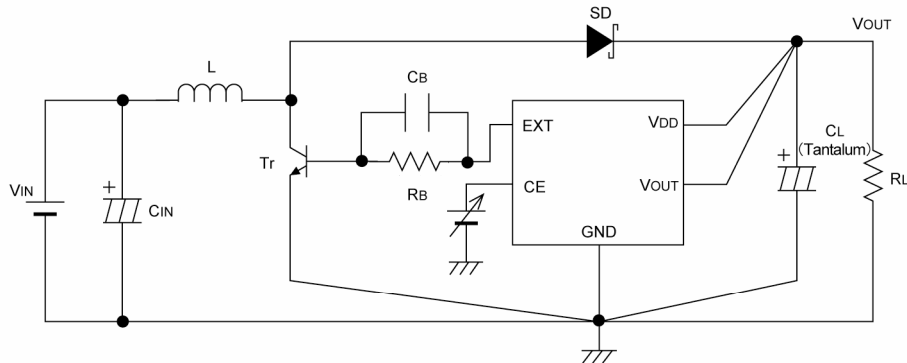

Circuit 8. XC6367B, XC6368B (NPN Transistor)

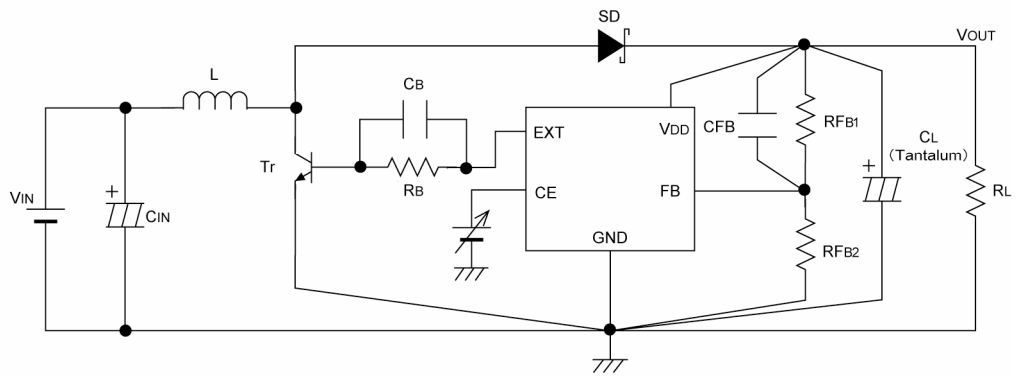

Circuit 9. XC6367C, XC6368C (NPN Transistor)

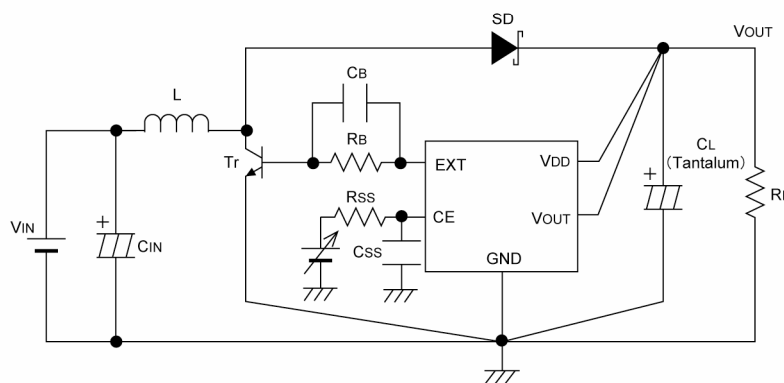

TEST CIRCUITS (Continued)

Circuit 10. XC6367D, XC6368D (NPN Transistor)

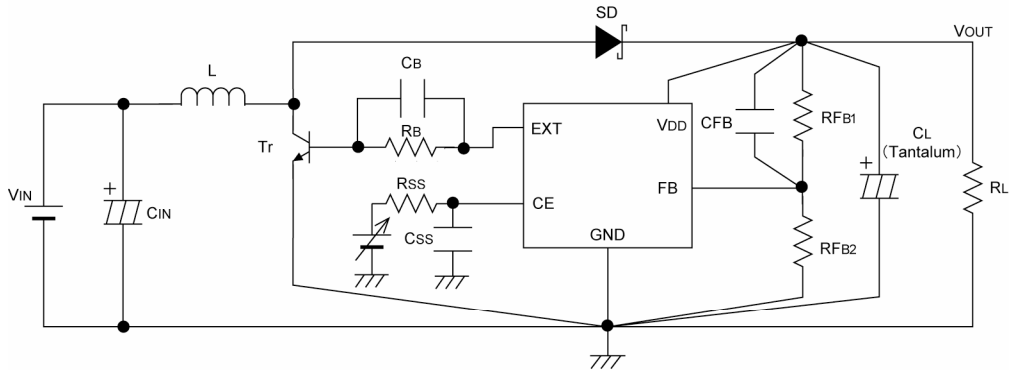

Circuit 11. XC6367E, XC6368E (NPN Transistor)

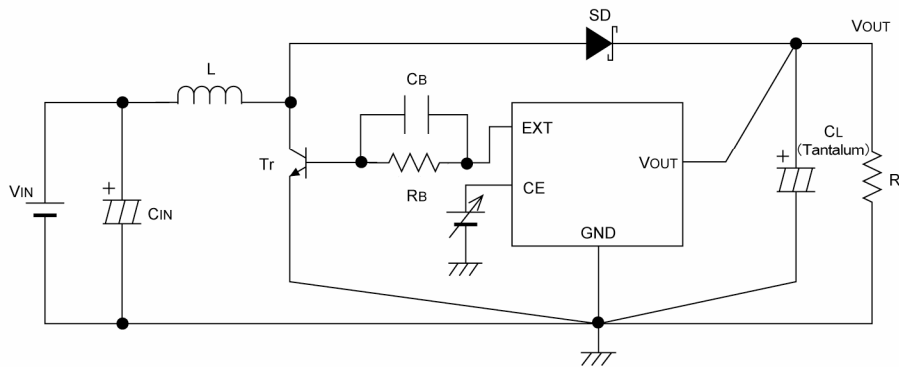

Circuit 12. XC6367F, XC6368F (NPN Transistor)

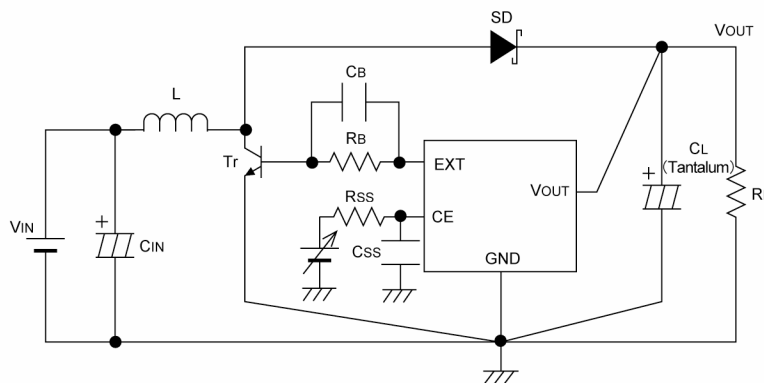

■ TEST CIRCUITS (Continued)

● External Components

Tr	: XP161A1355PR (N-ch Power MOSFET, TOREX) As the breakdown voltage of XP161A1355PR is 8V, take care with the power supply voltage. With output voltages over 6V, use the XP161A1265PR with a breakdown voltage of 12V. V _{ST1} : XP161A1355PR = 1.2V (MAX.) XP161A1265PR = 1.5V (MAX.)
L	: 22 μH (CR54, SUMIDA FOSC=300kHz) 47 μH (CR75, SUMIDA FOSC=100, 180kHz) 10 μH (CR54, SUMIDA FOSC=500kHz)
SD	: MA2Q735 (Schottky Diode, MATSUSHITA)
C _{IN}	: 16V, 220 μF (Aluminium Electrolytic Capacitor)
CL	: 16V, 47 μF + 47 μF (Tantalum capacitor, NICHICON MCE)

NPN Tr type:

Tr	: 2SD1628 (SANYO)
R _b	: 500 Ω (Adjust according to load and Tr. hFE levels)
C _b	: 2200pF (Ceramic Type)

$$\text{Set up so that } CB \leq 1 \div (2 \pi \times RB \times FOSC \times 0.7)$$

C, D, F type (soft-start externally set-up):

C _{SS}	: 0.1 μF (Ceramic Capacitor)
R _{SS}	: 470k Ω (C, F Type), 220k Ω (D Type)

B, D type (FB versions)

R _{FB}	: Set up so that $R_{FB1} \div R_{FB2} = V_{OUT} - 1$ (V_{OUT} = setting output voltage), Please use with $R_{FB1} + R_{FB2} \leq 2M \Omega$
C _{FB}	: Set up so that $f_{zfb} = 1 \div (2 \times \pi \times C_{FB} \times R_{FB1})$ is within the 0.1 to 20kHz range (10kHz conventional) Adjustments necessary in respect of L, CL.
e.g	$V_{OUT} = 3.0V$ $R_{FB1} = 400k \Omega$, $R_{FB2} = 200k \Omega$, $C_{FB} = 47pF$

For using MOSFET, We recommend using TOREX MOSFETs, which has a gate protection diode built-in.

GATE PROTECTION DIODE BUILT-IN MOSFET	R _{ds} (ON)
XP161A1355PR	0.15 Ω @ V _{gs} =1.5V
XP161A1265PR	0.095 Ω @ V _{gs} =2.5V

NOTES ON USE

1. Take ample care to ensure that none of the IC's, nor the external component's, absolute maximum ratings are exceeded.
2. Be extremely careful when selecting parts and do not limit your reference to the specifications and characteristics for the DC/DC converter alone. The IC also depends, to a great extent, upon the external components.
3. Arrange the peripherals in the environs of the IC. In order to reduce wiring impedance, use short, thick wires. In particular, wire the load capacitor as close as possible and strengthen the ground wiring sufficiently.
4. Ground current during switching may cause the IC's operations to become unstable due to changes in ground voltage, so please strengthen the IC's GND pin surroundings.

External Components

1. Setting soft-start time

In order to lengthen soft-start time we recommend that you use the C or D types of the series which have soft start time externally set-up.

Soft-start time (T_{SS}) is between MIN & MAX, as indicated in the graphs below, so please select soft-start capacitor value (C_{SS}) to suit your application.

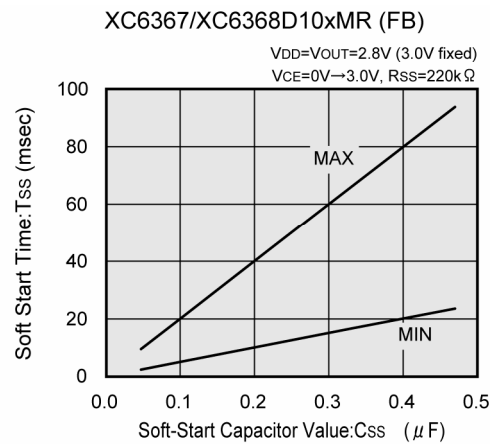
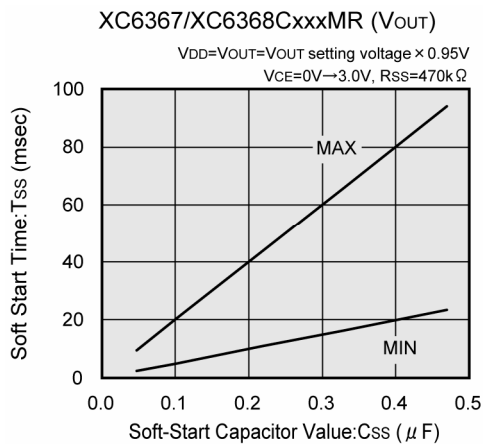

2. R_{FB1}, C_{FB} set up

$$f_{zfb} = 1 \div (2\pi \times C_{FB} \times R_{FB1})$$

In order to achieve a value for f_{zfb} within the range of 0.1kHz to 20kHz, we recommend that values for R_{FB1} & C_{FB} are selected from the area indicated within the lines of f_{zfb} = 0.1kHz and f_{zfb} = 20 kHz as shown on the graph below. Please select combinations of values as close to the f_{zfb} = 10kHz line as possible.

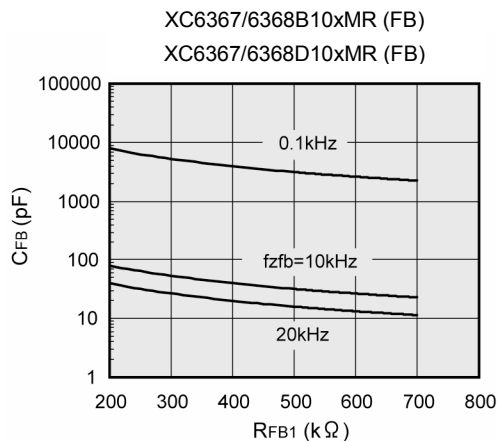

■ TYPICAL PERFORMANCE CHARACTERISTICS

(1) Output Voltage vs. Output Current

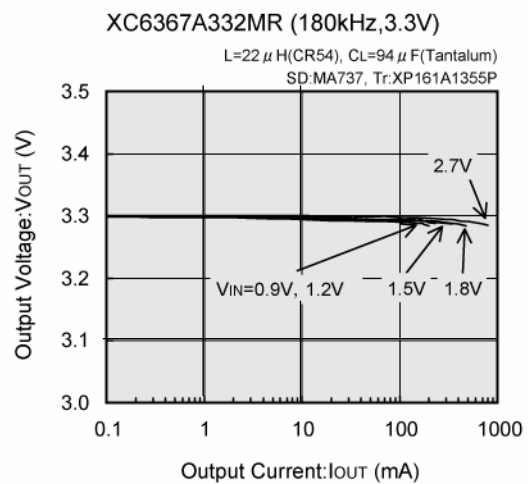
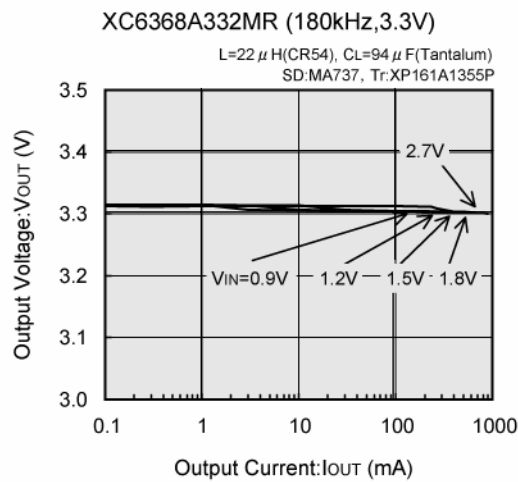
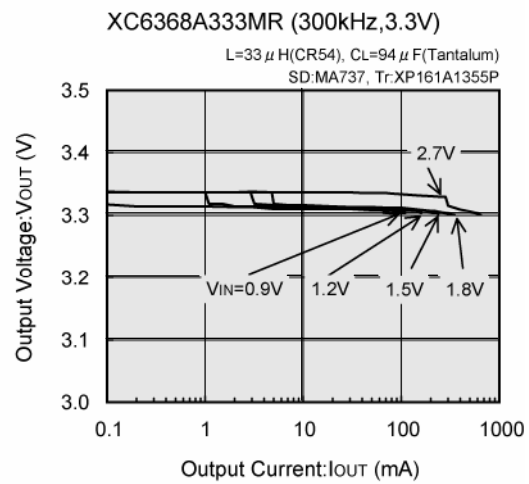
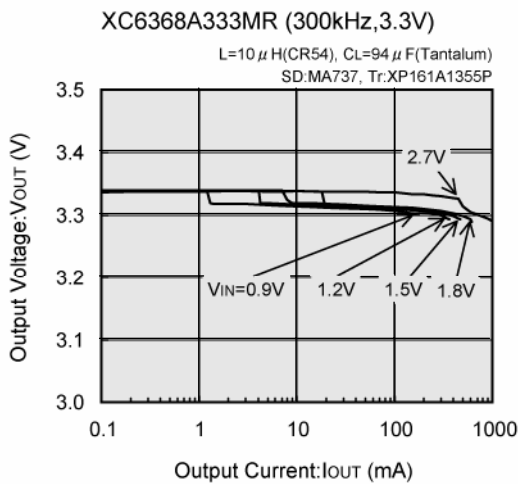
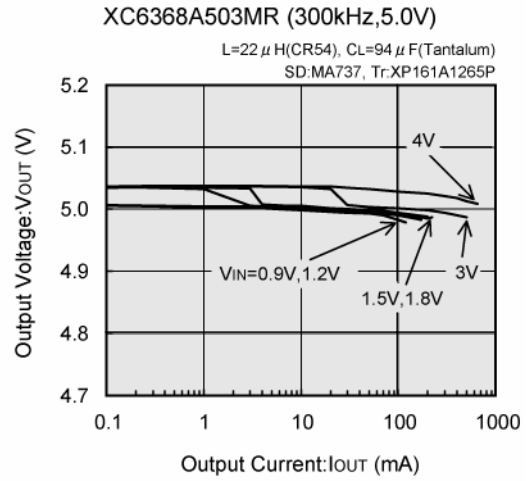
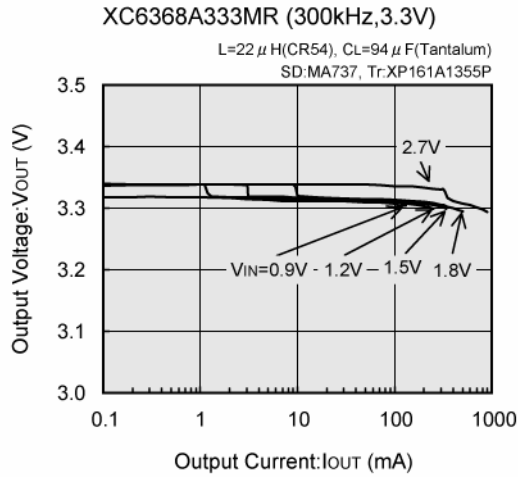

<External component> CIN=220 μ F (Electrolytic capacitor)

TYPICAL PERFORMANCE CHARACTERISTICS (Continued)

(1) Output Voltage vs. Output Current (Continued)

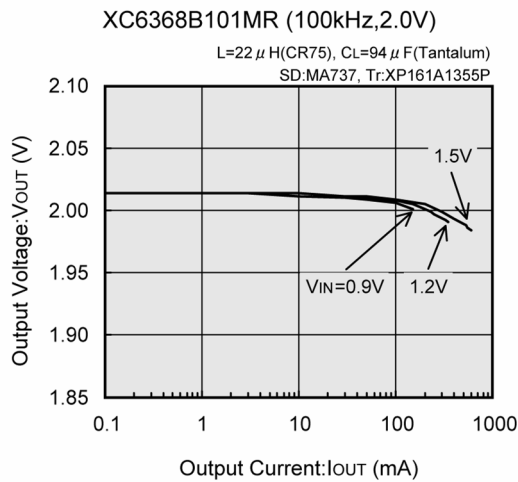
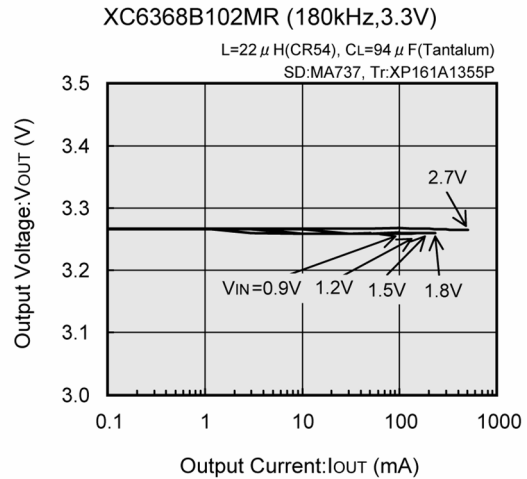
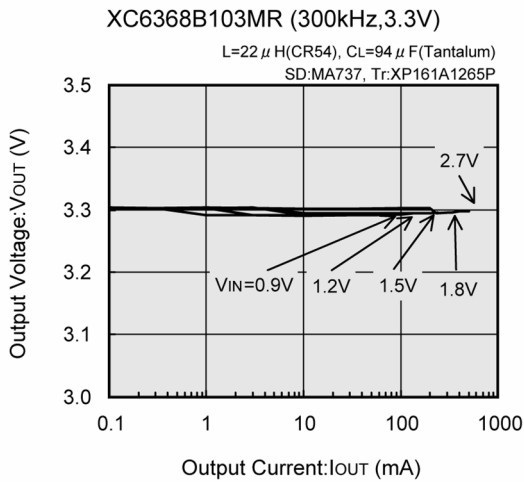
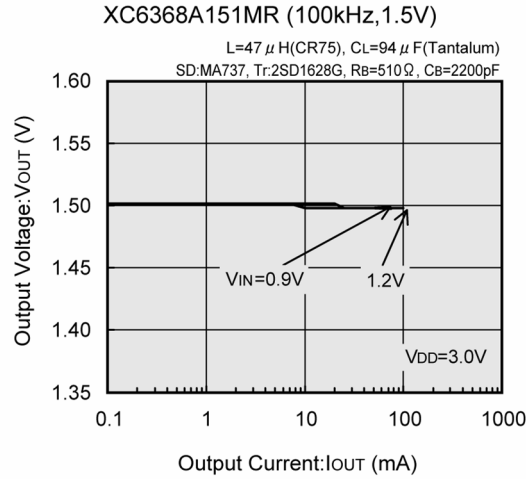
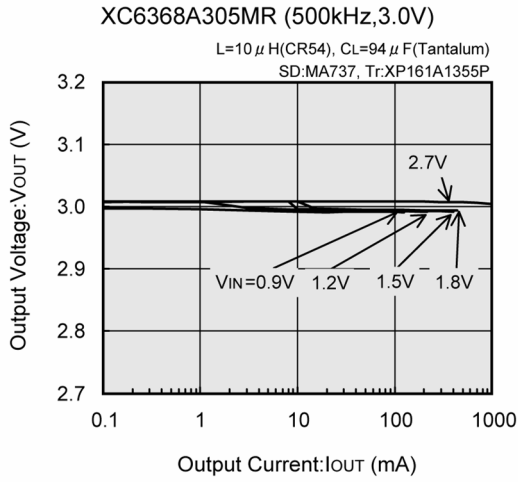

〈External component〉 CIN=220 μ F (Electrolytic capacitor)

■ TYPICAL PERFORMANCE CHARACTERISTICS (Continued)

(2) Efficiency vs. Output Current

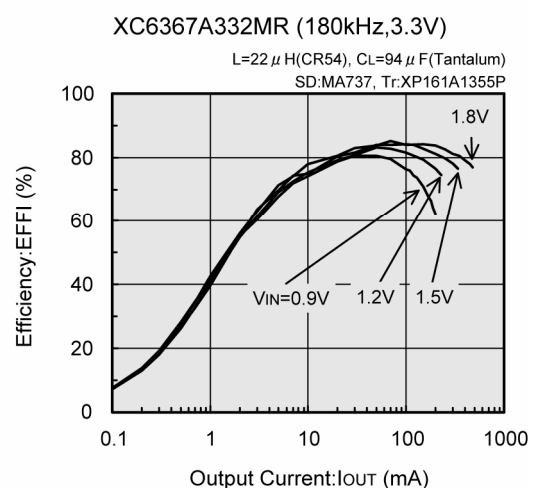
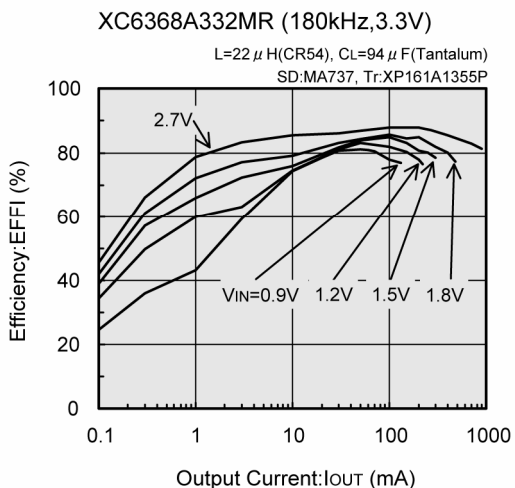
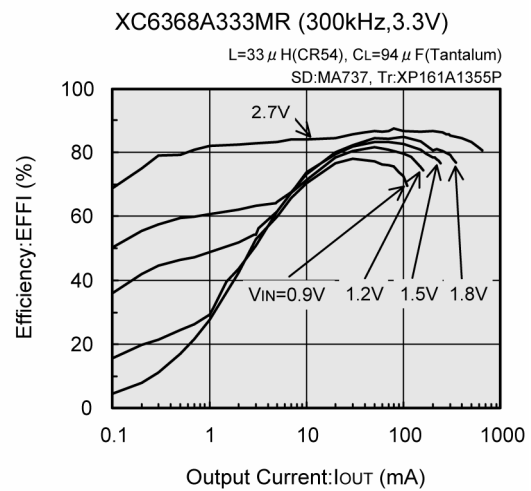
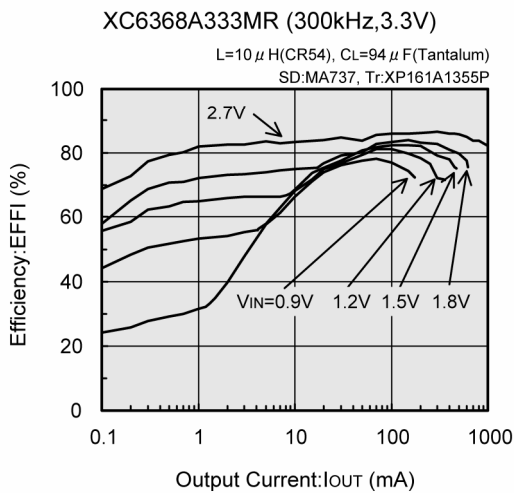
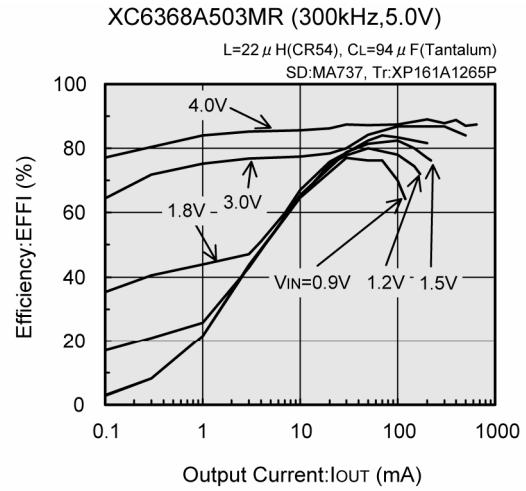
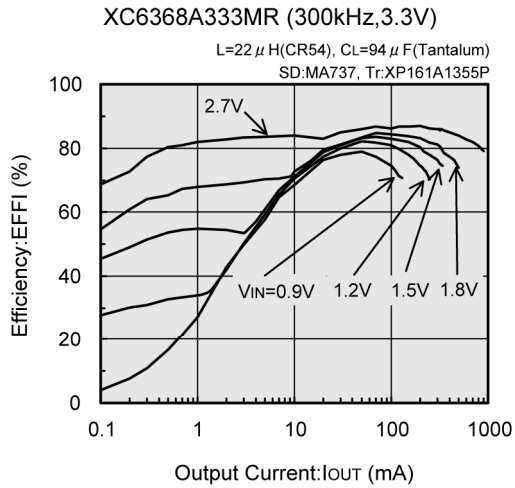

〈External component〉 CIN=220 μ F (Electrolytic capacitor)

TYPICAL PERFORMANCE CHARACTERISTICS (Continued)

(2) Efficiency vs. Output Current (Continued)

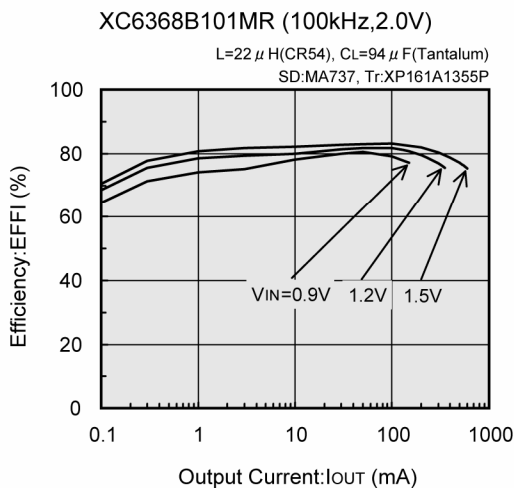
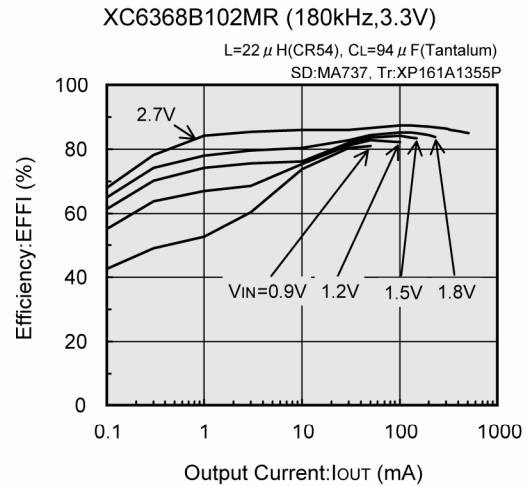
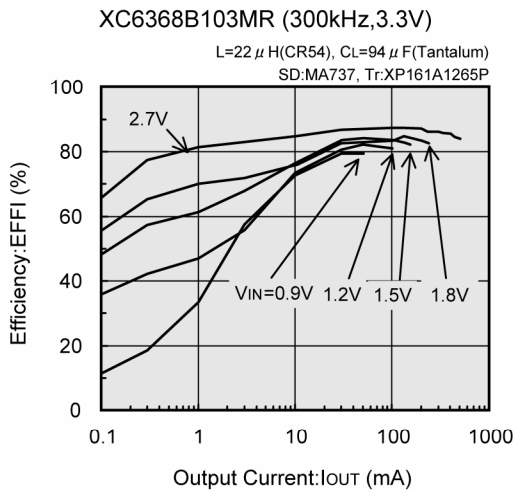
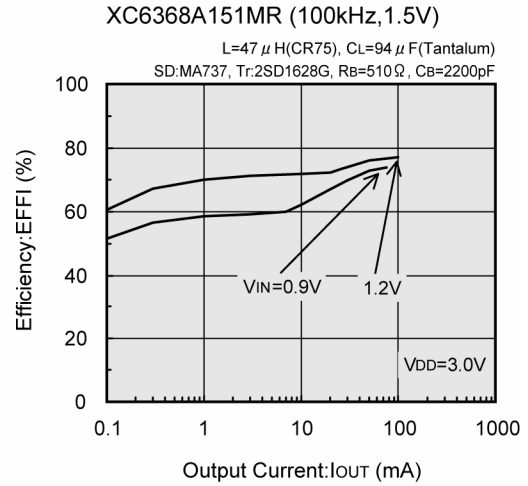
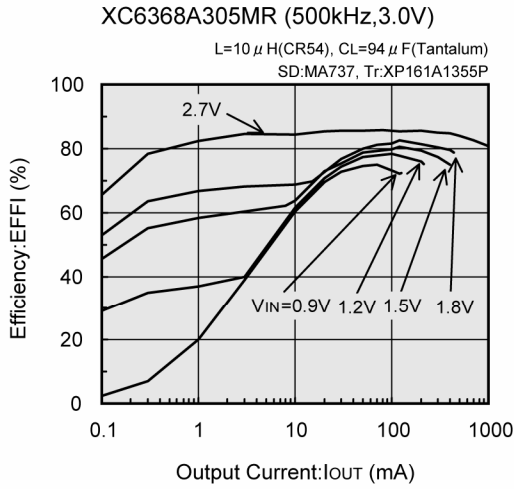

〈External component〉 CIN=220 μ F (Electrolytic capacitor)

■ TYPICAL PERFORMANCE CHARACTERISTICS (Continued)

(3) Ripple Voltage vs. Output Current

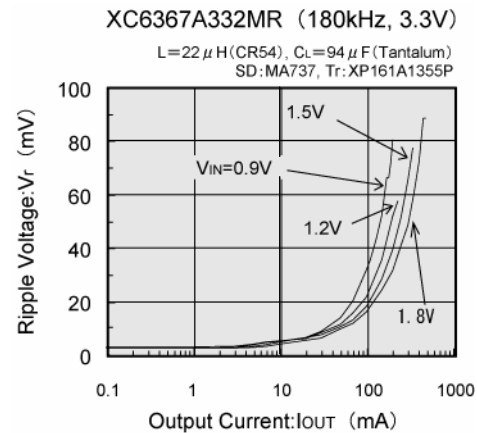
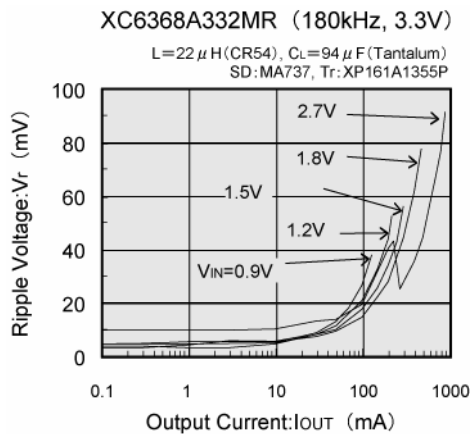
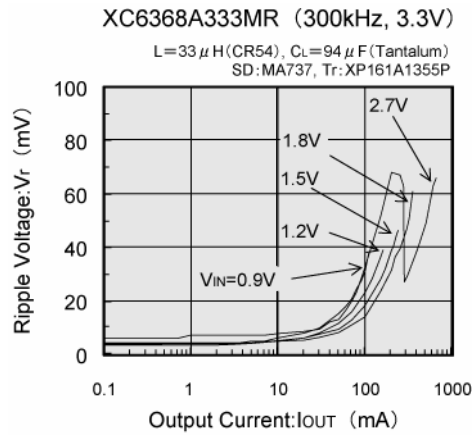
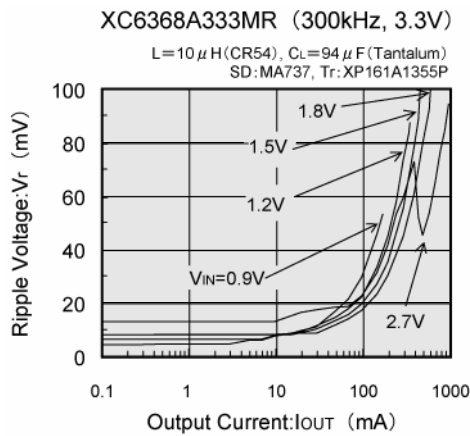
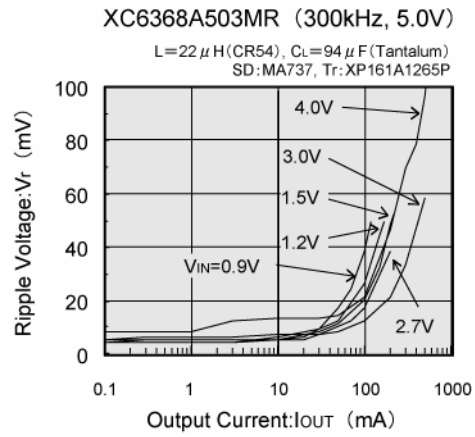
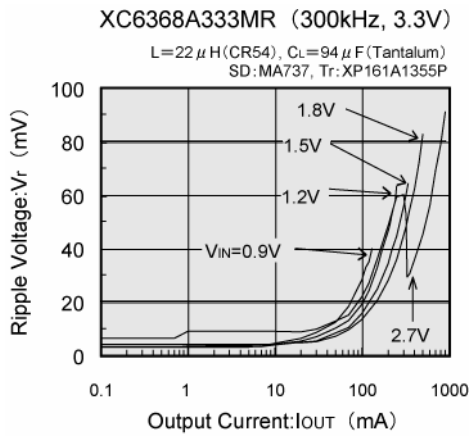

TYPICAL PERFORMANCE CHARACTERISTICS (Continued)

(3) Ripple Voltage vs. Output Current (Continued)

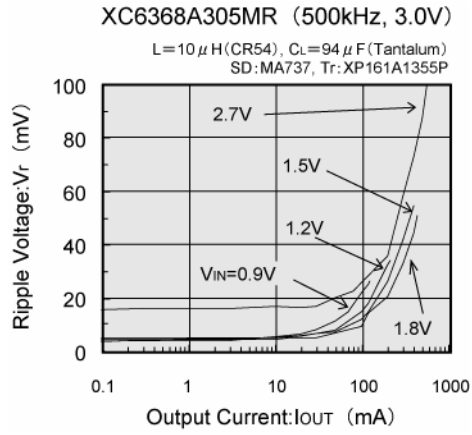

■ TYPICAL PERFORMANCE CHARACTERISTICS (Continued)

(4) Output Voltage vs. Ambient Temperature

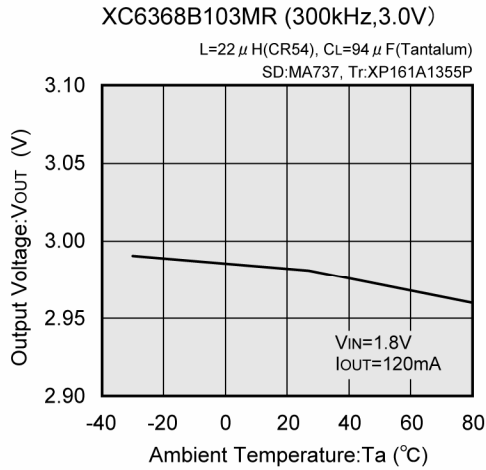

(5) Supply Current 1 vs. Ambient Temperature

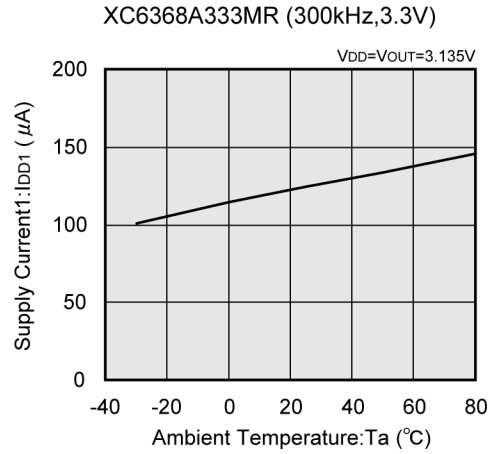

(6) Supply Current 2 vs. Ambient Temperature

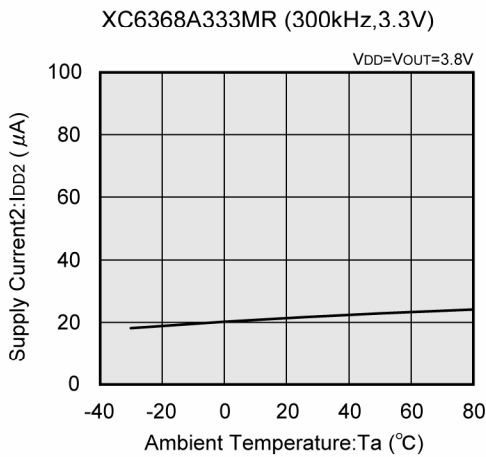

(7) Stand-by Current vs. Ambient Temperature

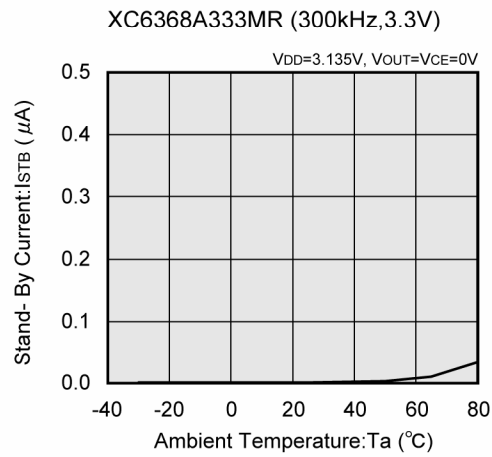

(8) EXT "H" ON Resistance vs. Ambient Temperature

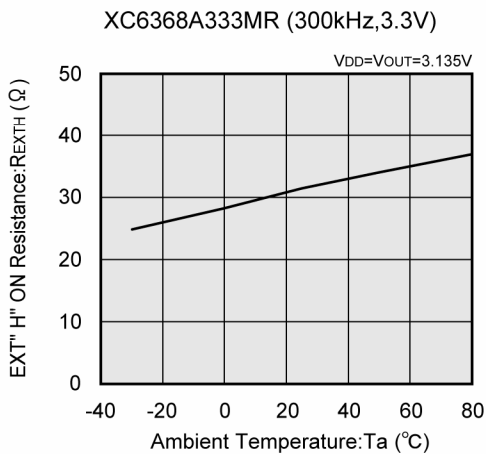

(9) EXT "L" ON Resistance vs. Ambient Temperature

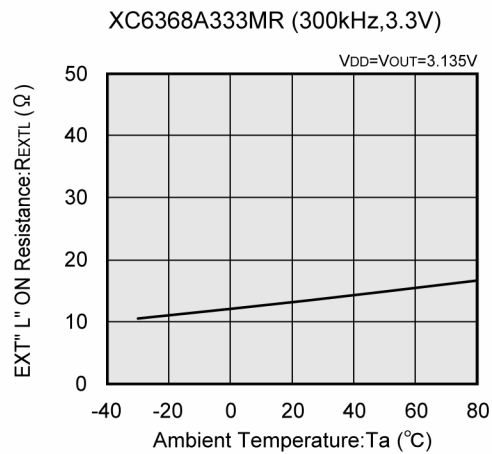

TYPICAL PERFORMANCE CHARACTERISTICS (Continued)

(10) Oscillation Frequency vs. Ambient Temperature

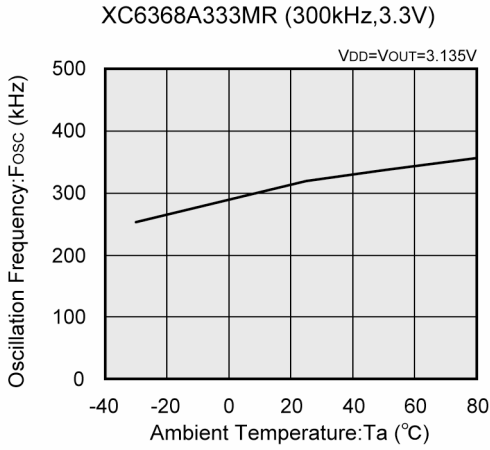

(11) Maximum Duty Ratio vs. Ambient Temperature

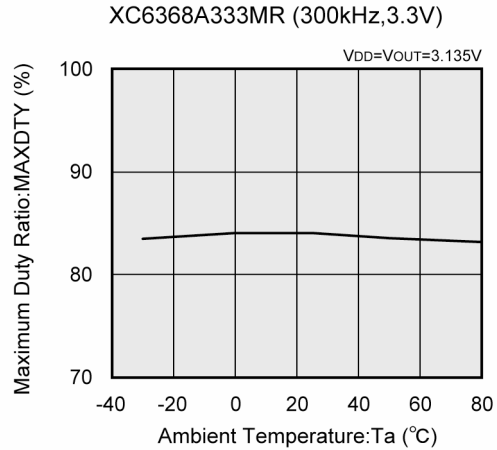

(12) PFM Duty Ratio vs. Ambient Temperature

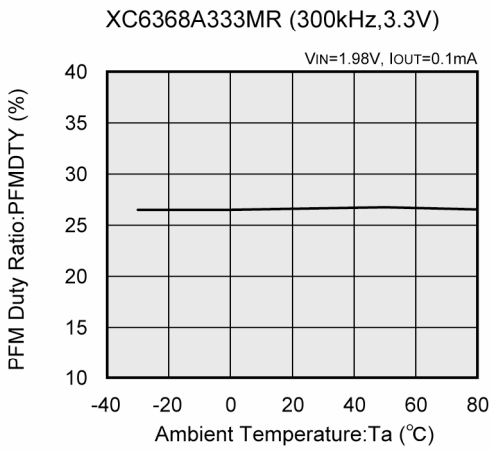

(13) Efficiency vs. Ambient Temperature

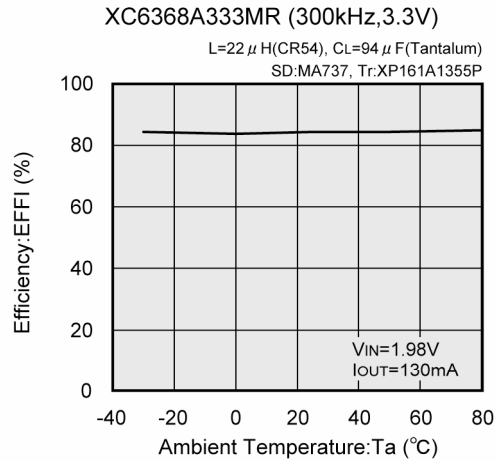

(14) Operation Start Voltage vs. Ambient Temperature

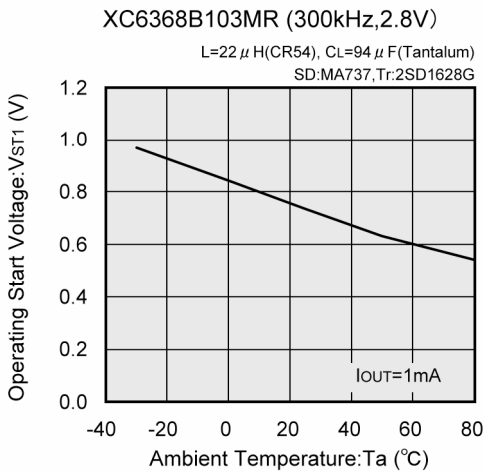

(15) Operation Hold Voltage vs. Ambient Temperature

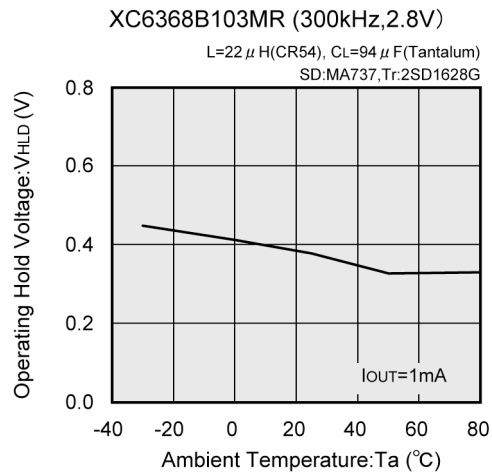

■ **TYPICAL PERFORMANCE CHARACTERISTICS (Continued)**

(16) Oscillation Start Voltage vs. Ambient Temperature

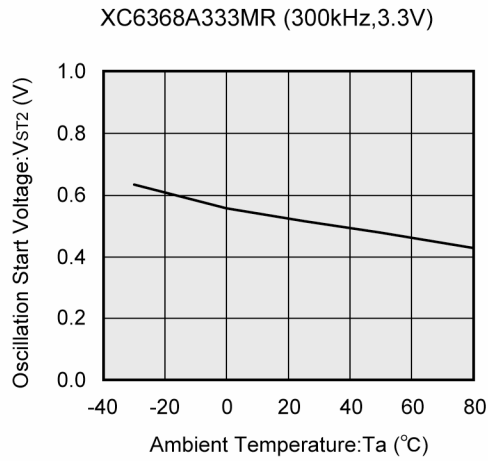

(17) Soft-Start Time vs. Ambient Temperature

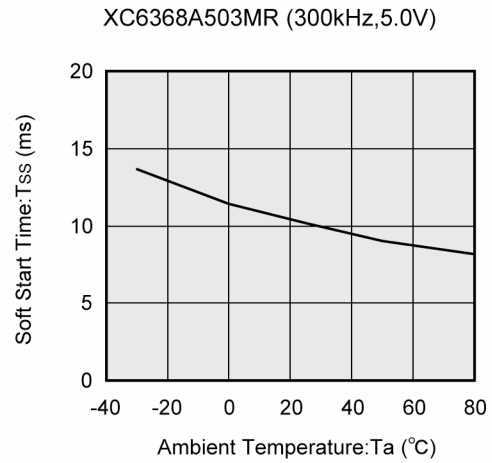

(18) CE "L" Voltage vs. Ambient Temperature

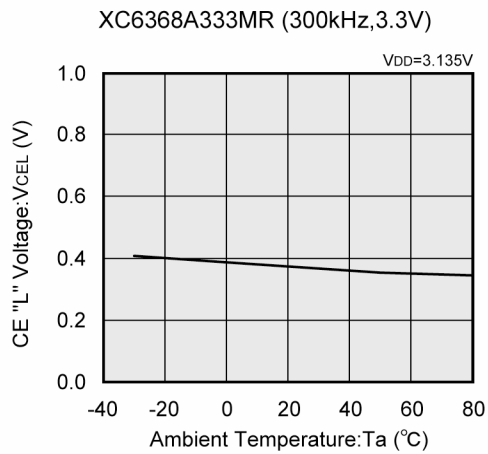

(19) CE "H" Voltage vs. Ambient Temperature

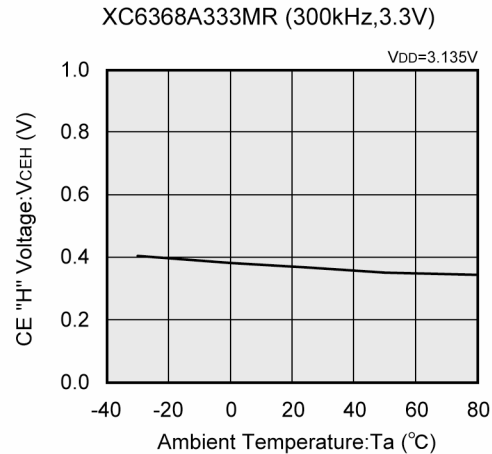

TYPICAL PERFORMANCE CHARACTERISTICS (Continued)

(20) Load Transient Response

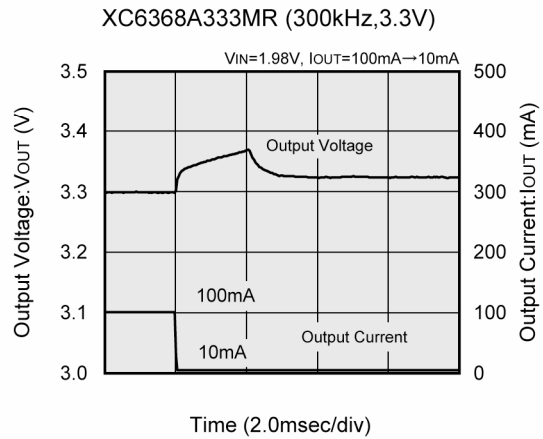
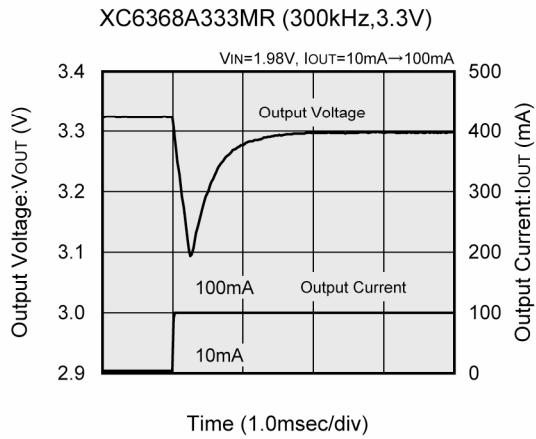
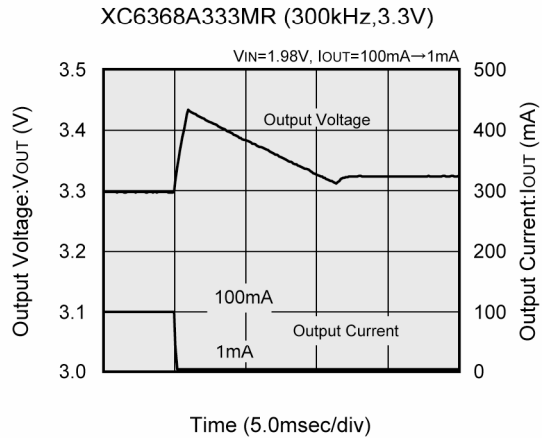
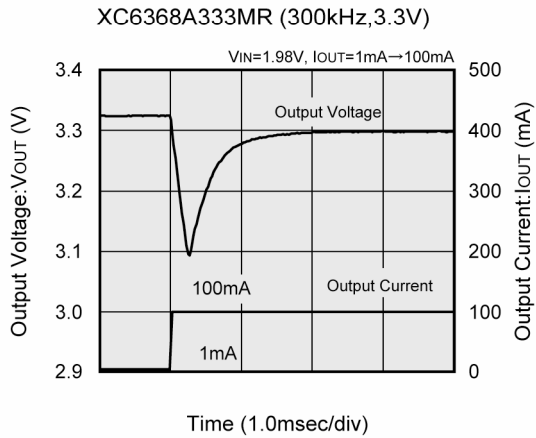
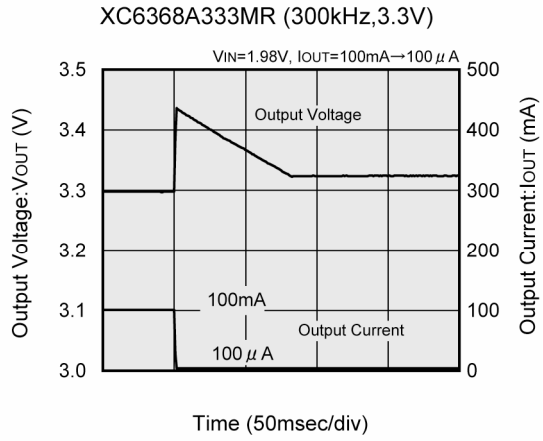
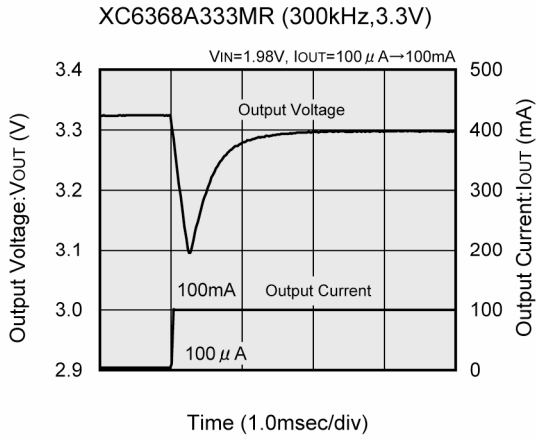

PACKAGING INFORMATION

● SOT-25

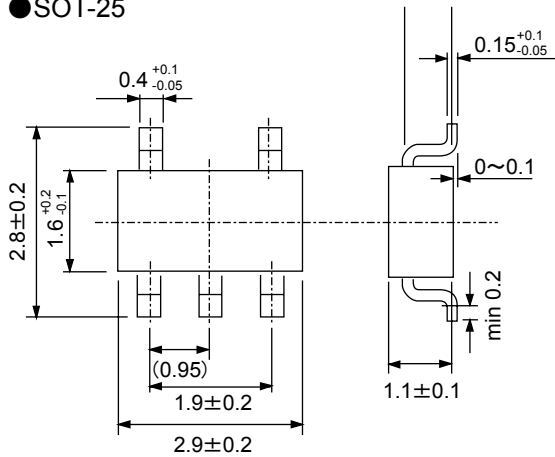

MARKING RULE

● XC6367/6368 Series

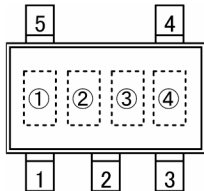

SOT-25
(TOP VIEW)

① Represents product series

MARK	PRODUCT SERIES	MARK	PRODUCT SERIES
<u>A</u>	XC6367A	<u>K</u>	XC6368A
<u>B</u>	XC6367B	<u>L</u>	XC6368B
<u>C</u>	XC6367C	<u>M</u>	XC6368C
<u>D</u>	XC6367D	<u>N</u>	XC6368D
<u>E</u>	XC6367E	<u>P</u>	XC6368E
<u>F</u>	XC6367F	<u>R</u>	XC6368F

② Represents integer of output voltage and oscillation frequency

OUTPUT VOLTAGE (V)	OSCILLATION FREQUENCY (kHz)			
	100	180	300	500
1	B	1	1	B
2	C	2	2	C
3	D	3	3	D
4	E	4	4	E
5	F	5	5	F
6	H	6	6	H
FOR CUSTOM PRODUCT	S			

③ Represents decimal number of output voltage and oscillation frequency

OUTPUT VOLTAGE (V)	OSCILLATION FREQUENCY (kHz)			
	100	180	300	500
0	0	0	A	A
1	1	1	B	B
2	2	2	C	C
3	3	3	D	D
4	4	4	E	E
5	5	5	F	F
6	6	6	H	H
7	7	7	K	K
8	8	8	L	L
9	9	9	M	M

④ Represents production lot number

0 to 9, A to Z repeated (G, I, J, O, Q, W excepted)

1. The products and product specifications contained herein are subject to change without notice to improve performance characteristics. Consult us, or our representatives before use, to confirm that the information in this catalog is up to date.
2. We assume no responsibility for any infringement of patents, patent rights, or other rights arising from the use of any information and circuitry in this catalog.
3. Please ensure suitable shipping controls (including fail-safe designs and aging protection) are in force for equipment employing products listed in this catalog.
4. The products in this catalog are not developed, designed, or approved for use with such equipment whose failure of malfunction can be reasonably expected to directly endanger the life of, or cause significant injury to, the user.
(e.g. Atomic energy; aerospace; transport; combustion and associated safety equipment thereof.)
5. Please use the products listed in this catalog within the specified ranges.
Should you wish to use the products under conditions exceeding the specifications, please consult us or our representatives.
6. We assume no responsibility for damage or loss due to abnormal use.
7. All rights reserved. No part of this catalog may be copied or reproduced without the prior permission of Torex Semiconductor Ltd.

TOREX SEMICONDUCTOR LTD.