



**Pb Free**

**RoHS Compliant**

### Features

- Miniature ceramic package
- Highly reliable with seam welding
- CMOS output
- Supply voltage  $V_{DD}=3.3V$
- Internal Bypass Capacitor
- Low Jitter
- $\pm 25ppm$  available

**Table 1**

Stability Code	Stability (ppm)	$T_{OPR}$ (°C)	Note
<b>0</b>	$\pm 50$	-10 to +70 (Standard)	Standard specifications
<b>S</b>	$\pm 30$	-10 to +70 (Standard)	With only certain frequencies
<b>U</b>	$\pm 25$	-10 to +70 (Standard)	With only certain frequencies
<b>F</b>	$\pm 100$	-40 to +85 (Extend)	With only certain frequencies
<b>G</b>	$\pm 50$	-40 to +85 (Extend)	With only certain frequencies

### How to Order

**K50H-3C 0 - S E 125.000**  
 ① ② ③ ④ ⑤

- ① Type(7x5 SMD, 3.3V)
- ② Frequency Stability Code(See Table 1)
- ③ Duty Ratio(S: 45% to 55% STD)
- ④ Enable/Disable Function(STD)
- ⑤ Oscillation Frequency(Ex.: 125.000MHz)

Packaging(Tape & Reel 1,000pcs/reel)

### Specifications

Item	Symbol	Conditions	Min.	Max.	Units	
Output Frequency Range	$F_{OUT}$		50	170	MHz	
Frequency Stability	$F_{SBY}$	Overall conditions: initial tolerance, operating temperature range, rated power supply voltage change, load change, aging(1year @25°C), shock and vibration	-25	+25	ppm	
			-30	+30		
			-50	+50		
Storage Temperature Range	$T_{STG}$		-55	+125	°C	
Operating Temperature Range	$T_{OPR}$	Standard	-10	+70		
		Extend(option)	-40	+85		
Max. Supply Voltage	—		-0.5	7.0	Volt	
Supply Voltage	$V_{DD}$	Stability: $\pm 50ppm, \pm 100ppm$ (Ext Temp)	2.97	3.63		
		Stability: $\pm 25ppm, \pm 30ppm, \pm 50ppm$ (Ext Temp)	3.14	3.46		
Current Consumption (Maximum Loaded)	$I_{DD}$	$50 \leq F_{OUT} \leq 85MHz$	—	30	mA	
		$85 < F_{OUT} \leq 100MHz$	—	40		
		$100 < F_{OUT} \leq 135MHz$	—	50		
		$135 < F_{OUT} \leq 160MHz$	—	60		
Duty Ratio(Symmetry)	$I_{ST}$	Standby Function	—	10	$\mu A$	
Duty Ratio(Symmetry)	SYM	@ 50% $V_{DD}$	45	55	%	
Rise/Fall Time (10% $V_{DD}$ to 90% $V_{DD}$ Maximum Loaded)	$T_r/T_f$	$50 \leq F_{OUT} < 100MHz$	20% $V_{DD}$ to 80% $V_{DD}$	—	3.5	nS
			10% $V_{DD}$ to 90% $V_{DD}$	—	5.0	
		$100 \leq F_{OUT} \leq 160MHz$	20% $V_{DD}$ to 80% $V_{DD}$	—	1.5	
			10% $V_{DD}$ to 90% $V_{DD}$	—	2.0	
Output Voltage-"L"	$V_{OL}$		—	10% $V_{DD}$	Volt	
Output Voltage-"H"	$V_{OH}$		90% $V_{DD}$	—		
Output Load	CL	CMOS	—	15	pF	
Input Voltage Range	$V_{IN}$		0	$V_{DD}$	Volt	
Input Voltage-"L"	$V_{IL}$		—	30% $V_{DD}$	Volt	
Input Voltage-"H"	$V_{IH}$		70% $V_{DD}$	—		
Output Disable Time	—		—	5	mS	
Output Enable Time	—		—	150	nS	
Start-up Time	ST	@ Minimum operating Voltage to be 0sec.	—	10	mS	
Deterministic Jitter pk-pk	DJ	Measured with "Wavecrest DTS-2079", VISI 6.3.1	—	2	psec	
1Sigma jitter	1sigma		—	4		

Note: Please contact us for inquire about extended operating temperature range, available frequencies and other conditions.  
 All electrical characteristics are defined at the maximum load and operating temperature range.

### Dimensions

(Unit : mm)

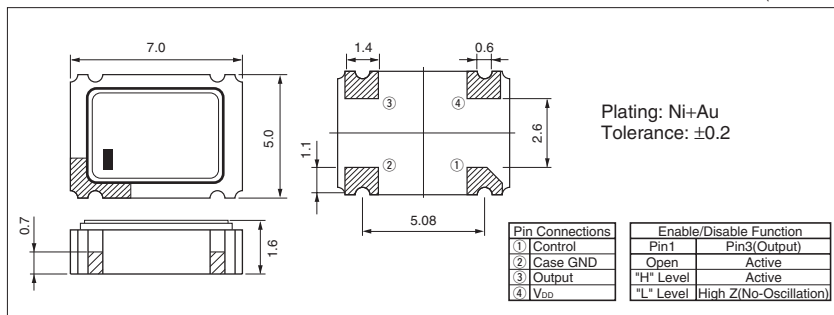

### Recommended Land Pattern

(Unit : mm)

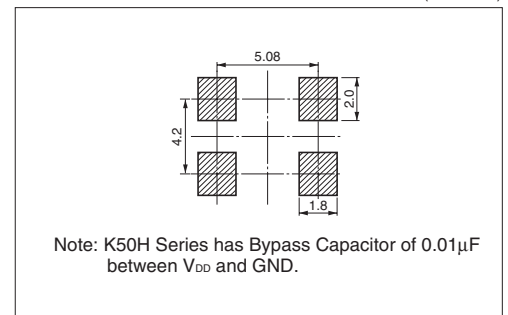

CMOS / 3.3V / 7.0x5.0mm

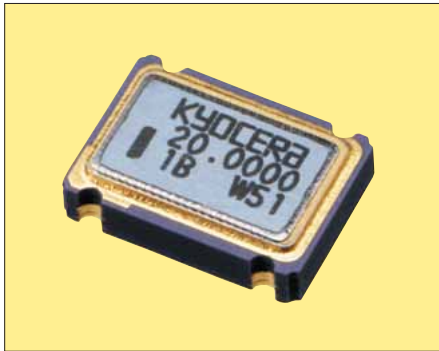

Pb Free

RoHS Comforming

**Features**

- Miniature ceramic package
- Highly reliable with seam welding
- CMOS output
- Supply voltage  $V_{DD}=3.3V$
- $\pm 25ppm$  available

**How to Order**

K50-3C 0 - S E 25.0000  
① ② ③ ④ ⑤

- ① Type(7x5 SMD, 3.3V)
- ② Frequency Stability Code(See Table1)
- ③ Duty Ratio(S: 45% to 55% STD)
- ④ Enable/Disable Function(STD)
- ⑤ Oscillation Frequency(Ex.: 25.0000MHz)

Packaging(Tape & Reel 1Kpcs/reel)

**Table 1**

Stability Code	Stability (ppm)	T <sub>OPR</sub> (°C)	Note
0	± 50	-10 to +70 (Standard)	Standard specifications
S	± 30		With only certain frequencies
U	± 25		
F	±100	-40 to +85 (Extend)	With only certain frequencies
G	± 50		

**Specifications**

Item	Symbol	Conditions	Min.	Max.	Units
Output Frequency Range	F <sub>OUT</sub>		1.5	80	MHz
Frequency Stability	F <sub>SBY</sub>	Overall conditions: initial tolerance, operating temperature range, rated power supply voltage change, load change, aging(1year @25°C), shock and vibration	-25 -30 -50	+25 +30 +50	ppm
Storage Temperature Range	T <sub>STG</sub>		-55	+125	°C
Operating Temperature Range	T <sub>OPR</sub>	Standard Extend(option)	-10 -40	+70 +85	
Max. Supply Voltage	—		-0.5	7.0	Volt
Supply Voltage	V <sub>DD</sub>	Stability: ±50ppm, ±30ppm, ±100ppm(Ext Temp) Stability: ±25ppm, ±50ppm(Ext Temp)	2.97 3.14	3.63 3.46	
Current Consumption (Maximum Loaded)	I <sub>DD</sub>	1.5<F <sub>OUT</sub> <=20MHz 20<F <sub>OUT</sub> <=40MHz 40<F <sub>OUT</sub> <=60MHz 60<F <sub>OUT</sub> <=80MHz	— — — —	10 15 20 30	mA
Standby/Disable Current	I <sub>ST</sub> /I <sub>DE</sub>	8<F <sub>OUT</sub> <=32MHz(Standby Function) 32<F <sub>OUT</sub> <=50MHz(Disable Function) 50<F <sub>OUT</sub> <=80MHz(Standby Function)	— — —	10 15 10	μA mA μA
Duty Ratio(Symmetry)	SYM	@50% V <sub>DD</sub>	45	55	%
Rise/Fall Time (10% V <sub>DD</sub> to 90% V <sub>DD</sub> Maximum Loaded)	T <sub>r</sub> /T <sub>f</sub>	8<F <sub>OUT</sub> <=26MHz 26<F <sub>OUT</sub> <=45MHz 45<F <sub>OUT</sub> <=80MHz	— — —	10 8 5	nS
Output Voltage-"L"	V <sub>OL</sub>	I <sub>OL</sub> =8mA	—	10% V <sub>DD</sub>	Volt
Output Voltage-"H"	V <sub>OH</sub>	I <sub>OH</sub> =-8mA	90% V <sub>DD</sub>	—	
Output Load	CL	CMOS	—	15	pF
Input Voltage Range	V <sub>IN</sub>		0	V <sub>DD</sub>	Volt
Input Voltage-"L"	V <sub>IL</sub>		—	30% V <sub>DD</sub>	
Input Voltage-"H"	V <sub>IH</sub>		70% V <sub>DD</sub>	—	
Output Disable Time	—		—	150	nS
Output Enable Time	—	8<F <sub>OUT</sub> <=32MHz 32<F <sub>OUT</sub> <=50MHz 50<F <sub>OUT</sub> <=80MHz	— — —	5 150 5	mS nS mS
Start-up Time	ST	@ Minimum operating Voltage to be 0sec.	—	10	mS

Note: Please contact us for inquires about extended operating temperature range, available frequencies and other conditions.  
All electrical characteristics are defined at the maximum load and operating temperature range.

**Dimensions**

(Unit : mm)

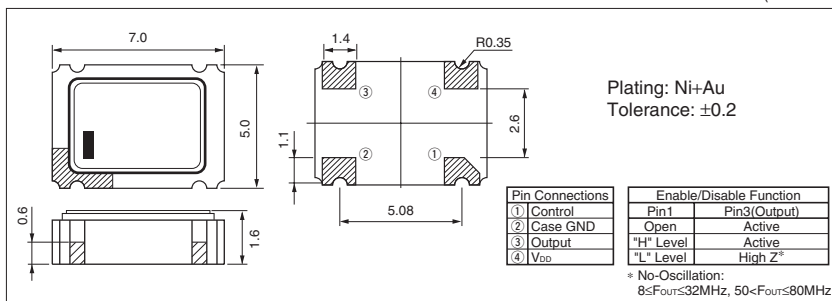

**Recommended Land Pattern**

(Unit : mm)

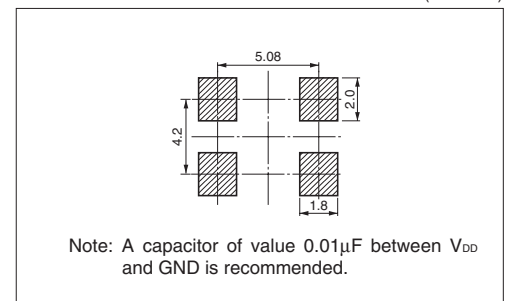

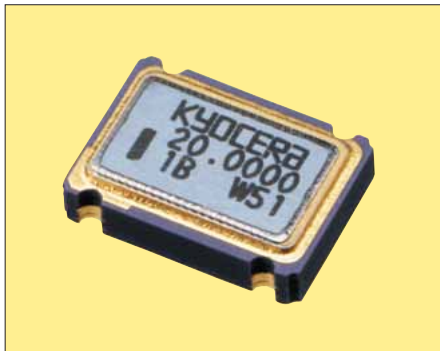

Pb Free

RoHS Conforming

### Features

- Miniature ceramic package
- Highly reliable with seam welding
- CMOS output
- Supply voltage  $V_{DD}=5.0V$
- $\pm 25ppm$  available

Table 1

Code	Stability (ppm)	$T_{OPR}$ (°C)	Note
S	$\pm 30$		With only certain frequencies
U	$\pm 25$		With only certain frequencies
F	$\pm 100$	-40 to +85 (Extend)	
G	$\pm 50$		

### How to Order

K50-HC 0 - C S E 25.0000  
 ① ② ③ ④ ⑤ ⑥

- ① Type(7x5 SMD, 5.0V)
- ② Frequency Stability Code(See Table1)
- ③ CMOS Output
- ④ Duty Ratio(S: 45% to 55% STD)
- ⑤ Enable/Disable Function(STD)
- ⑥ Oscillation Frequency(Ex.: 25.0000MHz)

Packaging(Tape & Reel 1Kpcs/reel)

### Specifications

Item	Symbol	Conditions	Min.	Max.	Units
Output Frequency Range	$F_{OUT}$		1.5	68	MHz
Frequency Stability	$F_{SBY}$	Overall conditions: initial tolerance, operating temperature range, rated power supply voltage change, load change, aging(1year @25°C), shock and vibration	-25	+25	ppm
			-30	+30	
			-50	+50	
Storage Temperature Range	$T_{STG}$		-55	+125	°C
Operating Temperature Range	$T_{OPR}$	Standard	-10	+70	
		Extend(option)	-40	+85	
Max. Supply Voltage	—		-0.5	7.0	Volt
Supply Voltage	$V_{DD}$	Stability: $\pm 50ppm, \pm 30ppm, \pm 100ppm$ (Ext Temp)	4.5	5.5	
		Stability: $\pm 25ppm, \pm 50ppm$ (Ext Temp)	4.75	5.25	
Current Consumption (Maximum Loaded)	$I_{DD}$	$1.5 < F_{OUT} \leq 20MHz$	—	25	mA
		$20 < F_{OUT} \leq 40MHz$	—	35	
		$40 < F_{OUT} \leq 68MHz$	—	50	
Disable Current	$I_{DE}$	@68.0000MHz	—	30	mA
Duty Ratio(Symmetry)	SYM	@50% $V_{DD}$	45	55	%
Rise/Fall Time (10% $V_{DD}$ to 90% $V_{DD}$ Maximum Loaded)	$T_r/T_f$	$8 < F_{OUT} \leq 26MHz$	—	10	nS
		$26 < F_{OUT} \leq 45MHz$	—	8	
		$45 < F_{OUT} \leq 68MHz$	—	5	
Output Voltage-"L"	$V_{OL}$	$I_{OL} = 16mA$	—	10% $V_{DD}$	Volt
Output Voltage-"H"	$V_{OH}$	$I_{OH} = -16mA$	90% $V_{DD}$	—	
Output Load(CMOS)	CL	$8 < F_{OUT} \leq 50MHz$	—	50	pF
		$50 < F_{OUT} \leq 68MHz$	—	15	
Input Voltage Range	$V_{IN}$		0	$V_{DD}$	Volt
Input Voltage-"L"	$V_{IL}$		—	0.8	Volt
Input Voltage-"H"	$V_{IH}$		2.2	—	
Output Disable Time	—		—	100	nS
Output Enable Time	—		—	100	nS
Start-up Time	ST	@ Minimum operating Voltage to be 0sec.	—	10	mS

Note: Please contact us for inquiries about extended operating temperature range, available frequencies and other conditions. All electrical characteristics are defined at the maximum load and operating temperature range.

### Dimensions

(Unit : mm)

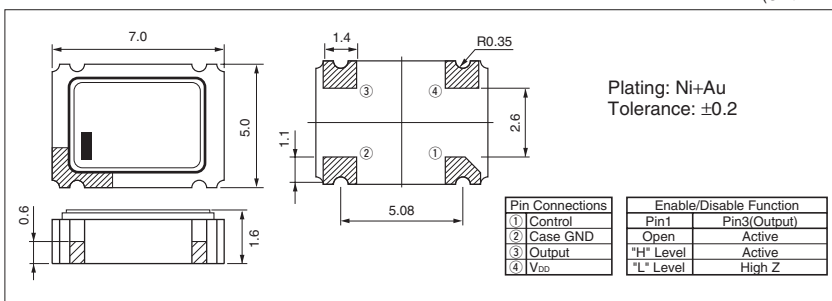

### Recommended Land Pattern

(Unit : mm)

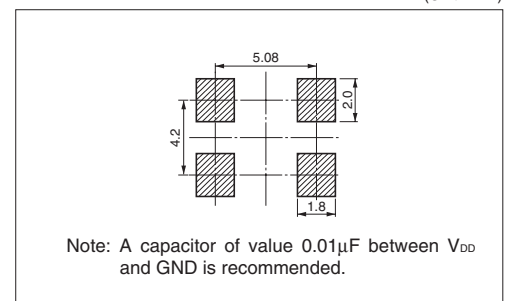

## 1. Shock & Drop • Vibration

Do not inflict excessive shock and mechanical vibration that exceeds the norm, such as hitting or mistakenly dropping, when transporting and mounting on a board. There are cases when pieces of crystal break, and pieces that are used become damaged, and become inoperable. When a shock or vibration that exceeds the norm has been inflicted, make sure to check the characteristics.

## 2. Cleaning

Since a crystal piece can be broken by resonance when a crystal device is cleaned by ultrasonic cleaning. Be careful when carrying out ultrasonic cleaning.

## 3. Soldering conditions

To maintain the product reliability, please follow recommended conditions.

### Standard soldering iron conditions

	Crystal Oscillators
Soldering iron	280°C ~ 340°C
Time	3+1/-0sec. max

### Reflow conditions (Example)

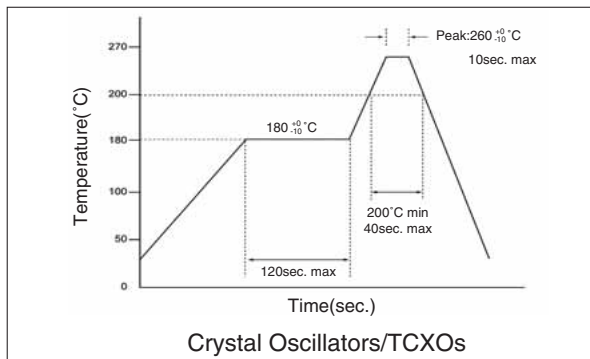

Recommended reflow Conditions vary depending upon products. Please check with the respective specification for details.

## 4. Mounting Precautions

### Leaded Devices

The special glass, located where the lead of the retainer base comes out, is aligned with the coefficient of thermal expansion of the lead. If the glass is damaged and cracks appear, there may be cases in which performance deteriorates and it fails to operate.

Consequently, when making the device adhere closely and applying solder, align the gap of the hole of the board with the gap of the lead and insert without excessive force.

When making the device adhere closely to a through hole board and applying solder, be careful that the solder does not get into the metal part of the retainer base and cause a short. Putting in an insulation spacer is one more method of preventing a short circuit.

When the lead is mounted floating, fix it as far as possible so that contact with other parts and the breakage due to the fatigue, and the mechanical resonance of the lead will not occur.

When the lead is bent and used, do not bend the lead directly from the base, separate it 0.5mm or more and then bend it. When bending, before attaching to the board, fix the place where the lead comes out in advance and attach it after bending so that a crack does not occur in the glass part.

### Surface Mount Devices

The lead of the device and the pattern of the board is soldered on the surface. Since extreme deformation of the board tears off the pattern, tears off the lead metal, cracks the solder and damages the sealed part of the device and there are cases in which performance deteriorates and operation fails, use it within the stipulated bending conditions. Due to the small cracks in the board resulting from mounting, please pay sufficient attention when attaching a device at the position where the warping of the board is great.

When using an automatic loading machine, as far as possible, select a type that has a small impact and use it while confirming that there is no damage.

Surface mount devices are NOT flow soldering compatible.

## 5. Storage Condition

Since the long hour high temperature and low temperature storage, as well as the storage at high humidity are causes of deterioration in frequency accuracy and solderability.

Parts should be stored in temperature range of -5 to +40°C, humidity 40 to 60% RH, and avoid direct sunlight. Then use within 6 months.

## 6. In order to use crystal oscillators

- (1) The miniature crystal oscillator for the clock utilizes a C-MOS IC and incorporates a protective circuit against static electricity. However, exercise care in the same manner as for a normal C-MOS IC.
- (2) Internal capacitor is not provided in the power supply section (+DC-GND).  
To serve as overimpressed voltage and overcurrent protective device, place a bypass capacitor (0.01  $\mu$ F) as near as possible to the (+DC-GND) terminal.  
However, the capacity value is meant as a guideline.  
Depending on the capacitor type, frequency characteristics vary. Accordingly, use a capacitor that matches the frequency characteristics.
- (3) Applying reverse voltage could result in damage to internal parts. Take care not to connect terminals incorrectly.
- (4) Please do not use oscillators under unfavorable condition such as beyond specified range in catalog or specification sheet.
- (5) Please keep oscillators away from water, salt water or harmful gas.
- (6) K50H-3C / FSO series should be stored in humidity-controlled area after the package is unsealed, in temperature  $+25\pm 5^{\circ}\text{C}$  under humidity of 65%RH, and should be mounted on PCB within 7 days.
- (7) K50H-3C / FSO series has Bypass Capacitor between VDD and GND.

## Test Circuits and Clock Timing Chart

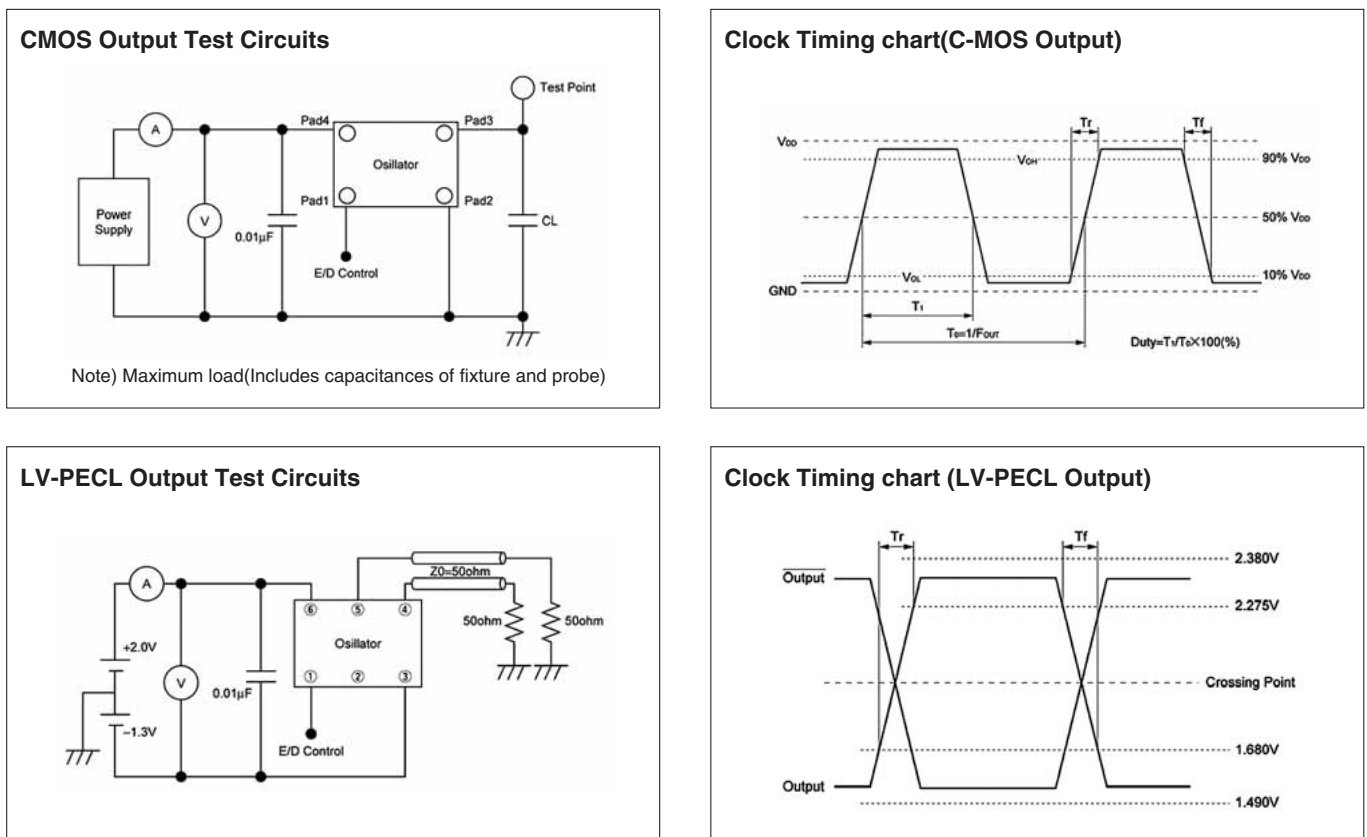

Tape & Reel Specifications

Crystal Oscillators

	KC2520	K25	K30	FXO-61F FXO-64F VC-FXO-65F	
T A P E	A	2.0±0.1	2.0±0.1	2.0±0.1	
	B	4.0±0.1	4.0±0.1	4.0±0.1	
	C	φ1.5+0.1/-0	φ1.5+0.1/-0	φ1.5+0.1/-0	φ1.55±0.1
	D	4.0±0.1	8.0±0.1	8.0±0.1	8.0±0.1
	E	3.5±0.05	3.5±0.05	5.5±0.1	5.5±0.1
	F	1.75±0.1	1.75±0.1	1.75±0.1	1.75±0.1
	G	8.0±0.2	8.0±0.2	12.0±0.2	12.0±0.3
	H	φ1.1±0.1	φ1.55±0.1	φ1.55±0.1	φ1.55±0.1
	J	2.7±0.1	3.5±0.05	5.5±0.1	5.4±0.1
	L	2.2±0.1	2.8±0.05	3.7±0.1	3.6±0.1
	N	1.25±0.1	1.1±0.05	1.4±0.1	1.7±0.1
O	0.2±0.05	0.3±0.05	0.3±0.05	0.3±0.05	
R E E L	P	φ180+0/-3	φ180+0/-3	φ180+0/-3	φ254±2
	Q	φ60+1/-0	φ60+1/-0	φ60+1/-0	φ100±1
	R	φ13±0.2	φ13±0.2	φ13±0.2	φ13±0.5
	S	φ21±0.8	φ21±0.8	φ21±0.8	φ21±0.8
	U	2.0±0.5	2.0±0.5	2.0±0.5	2.0±0.5
	W	9.0±0.3	9.0±0.3	13.0±0.3	13.4±2/-0
Qty	2000	2000	1000	1000	

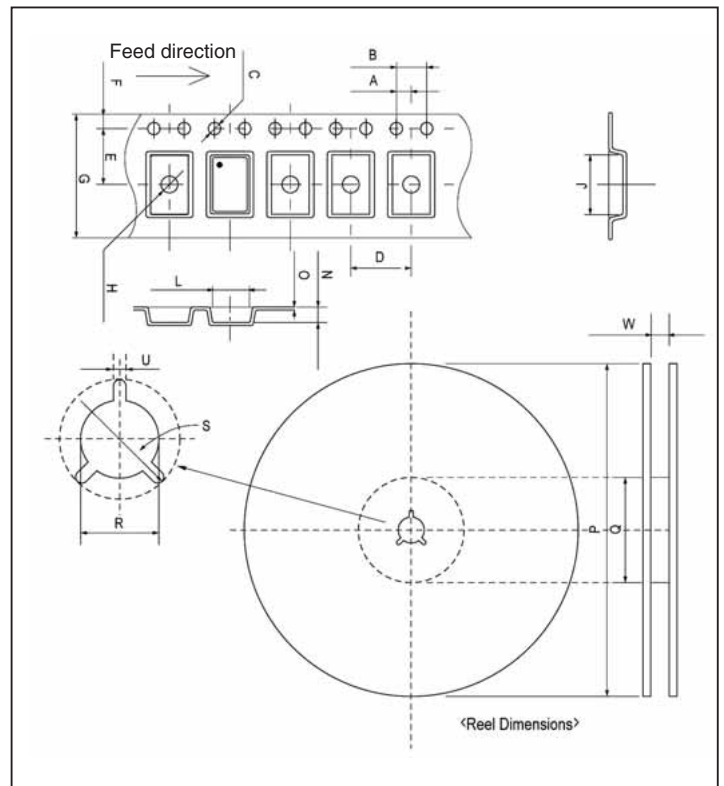

	FSO-1C/1D FSO-2B/2C/2D VC-FSO-1D	FXO-31F FXO-34F FXO-37F VC-FXO-35F VCXO-7050	K50H K50 K53 K50V-3P	KT21	(VC)TCXO-214C	(VC)TCXO-212C	(VC)TCXO-208C MFO-208F	KT18B	KT20A	(VC)TCXO-204C	
T A P E	A	2.0±0.1	2.0±0.1	2.0±0.1	2.0±0.1	2.0±0.1	2.0±0.1	2.0±0.1	2.0±0.1	2.0±0.1	
	B	4.0±0.1	4.0±0.1	4.0±0.1	4.0±0.1	4.0±0.1	4.0±0.1	4.0±0.1	4.0±0.1	4.0±0.1	
	C	φ1.55±0.1	φ1.55±0.1	φ1.5±0.1	φ1.5+0.1/-0	φ1.5+0.1/-0	φ1.5+0.1/-0	φ1.5+0.1/-0	φ1.5+0.1/-0	φ1.5+0.1/-0	
	D	8.0±0.1	8.0±0.1	8.0±0.1	4.0±0.1	4.0±0.1	4.0±0.1	8.0±0.1/4.0±0.1	8.0±0.1/4.0±0.1	8.0±0.1	4.0±0.1
	E	7.5±0.1	7.5±0.1	7.5±0.1	3.5±0.1	3.5±0.05	5.5±0.1	5.5±0.1	5.5±0.1	5.5±0.1	7.5±0.1
	F	1.75±0.1	1.75±0.1	1.75±0.1	1.75±0.1	1.75±0.1	1.75±0.1	1.75±0.1	1.75±0.1	1.75±0.1	1.75±0.1
	G	16.0±0.3	16.0±0.3	16.0±0.2	8.0±0.3	8.0±0.2	8.0±0.3/12.0±0.3	12.0±0.3	12.0±0.3	12.0±0.3	16.0±0.3
	H	φ1.55	φ1.55	φ1.55±0.1	φ1.5+0.1/-0	φ1.0+0.2/-0	φ1.5+0.1/-0	φ1.5+0.1/-0	φ1.5+0.1/-0	φ1.5+0.1/-0	φ1.5+0.1/-0
	J	8.18	8.18	7.4±0.1	3.5±0.1	3.6±0.1	4.4±0.1	5.5±0.1	5.5±0.1	5.5±0.1	7.4±0.1
	L	5.56	5.56	5.4±0.1	2.8±0.1	2.9±0.1	2.9±0.1	3.7±0.1	3.7±0.1	3.7±0.1	5.4±0.1
	N	2.16±0.1	2.16±0.1	2.0±0.1	1.1±0.1	1.3±0.1	1.1±0.1/1.3±0.1	1.6±0.1/1.5±0.1	1.6±0.1/1.5±0.1	1.8±0.1	2.1±0.1
O	0.3±0.05	0.3±0.05	0.3±0.05	0.25±0.05	0.3±0.05	0.2±0.05/0.3±0.05	0.3±0.05	0.3±0.05	0.3±0.05	0.3±0.05	
R E E L	P	φ330±2φ254±2	φ330±2φ254±2	φ180+0/-3	φ180±2	φ180+1/-1.5	φ254±1/φ180+1/-1.5	φ330±1	φ330±1	φ330±1	φ254±2
	Q	φ100±1	φ100±1	φ60+1/-0	φ60	φ60+1/-0	φ100±1/φ60+1/-0	φ100±1/φ60	φ100±1/φ60	φ100±1	φ100±1
	R	φ13±0.3	φ13±0.3	φ13±0.2	φ13±0.2	φ13±0.2	φ13±0.2	φ13±0.2	φ13±0.2	φ13±0.2	φ13±0.2
	S	φ21±0.8	φ21±0.8	φ21±0.8	φ21±0.8	φ21±0.8	φ21±0.8	φ21±0.8	φ21±0.8	φ21±0.8	φ21±0.8
	U	2.0±0.5	2.0±0.5	2.0±0.5	2.0±0.5	2.0±0.5	2.0±0.5	2.0±0.5	2.0±0.5	2.0±0.2	2.0±0.5
	W	16.4	17.5±0.5/16.4	17±0.2	9.0±0.1	9.0+0.3/-0	9.0±0.3/13.0+0.3-0	13.5±1	13.5±1	13.5±1	17.5±0.5
Qty	3000/1000	3000/1000	1000	2000	2000	4000/2000	2000	4000	4000	1000	

**ORDERING FORMAT FOR CRYSTAL OSCILLATORS**

Please specify the following items when ordering crystal oscillators.

**I. Standard products shown in the catalogue:**

Please specify package type and nominal frequency.

**II. Special-order products:**

Please specify the following items in specification.

**1 . Frequency**

(1)Oscillation Frequency \_\_\_\_\_ Hz

**2 . Frequency Stability**

(1)Temperature \_\_\_\_\_  $\times 10^{-6}$  MAX. \_\_\_\_\_ ~ \_\_\_\_\_ °C (On the basis of +25°C frequency)

(2)Supply Voltage \_\_\_\_\_  $\times 10^{-6}$  MAX. \_\_\_\_\_ VDC  $\pm$  \_\_\_\_\_ %

(3)Load. \_\_\_\_\_  $\times 10^{-6}$  MAX. \_\_\_\_\_  $\Omega$ // \_\_\_\_\_ pF  $\pm$  \_\_\_\_\_ %  $\pm$  \_\_\_\_\_ %

(4)Aging \_\_\_\_\_  $\times 10^{-6}$  MAX./year

**3 . Frequency Tuning Range**

$\pm$  \_\_\_\_\_  $\times 10^{-6}$  MIN

**4 . Frequency Control Range**

$\pm$  \_\_\_\_\_  $\sim \pm$  \_\_\_\_\_  $\times 10^{-6}$  /+ \_\_\_\_\_ V  $\pm$  \_\_\_\_\_ V

**5 . Output**

(1)Voltage \_\_\_\_\_ Vrms \_\_\_\_\_ V<sub>P-P</sub> MIN.

(2)Wave Form

Sine, Half sine wave, Harmonics 2nd \_\_\_\_\_ dB, 3rd \_\_\_\_\_ dB, Others \_\_\_\_\_ dB

(3)Load Resistance \_\_\_\_\_  $\Omega$ //Capacitance \_\_\_\_\_ pF

**6 . Supply Voltage**

(1)For circuit \_\_\_\_\_ VDC  $\pm$  \_\_\_\_\_ %, \_\_\_\_\_ mA MAX.

**7 . Environmental Condition**

(1)Operating Temperature Range \_\_\_\_\_ ~ \_\_\_\_\_ °C

(2)Vibration

Total Amplitude \_\_\_\_\_ mm, Vibration Frequency \_\_\_\_\_ Hz~ \_\_\_\_\_ Hz

(3)Shock \_\_\_\_\_

**8 . Dimensions, Pin Connection \_\_\_\_\_**
**9 . Application \_\_\_\_\_**