

RELIABILITY REPORT
FOR
MAX1644EAE
PLASTIC ENCAPSULATED DEVICES

February 11, 2002

MAXIM INTEGRATED PRODUCTS

120 SAN GABRIEL DR.

SUNNYVALE, CA 94086

Written by



Jim Pedicord
Quality Assurance
Reliability Lab Manager

Reviewed by



Bryan J. Preeshl
Quality Assurance
Executive Director

Conclusion

The MAX1644 successfully meets the quality and reliability standards required of all Maxim products. In addition, Maxim's continuous reliability monitoring program ensures that all outgoing product will continue to meet Maxim's quality and reliability standards.

Table of Contents

| | |
|-----------------------------------|--------------------------------------|
| I.Device Description | V.Quality Assurance Information |
| II.Manufacturing Information | VI.Reliability Evaluation |
| III.Packaging Information | |
| IV.Die Information |Attachments |

I. Device Description

A. General

The MAX1644 constant-off-time, PWM step-down DC-DC converter is ideal for use in applications such as PC cards, CPU daughter cards, and desktop computer bus-termination boards. The device features internal synchronous rectification for high efficiency and reduced component count. It requires no external Schottky diode. The internal 0.10Ω PMOS power switch and 0.10Ω NMOS synchronous-rectifier switch easily deliver continuous load currents up to 2A. The MAX1644 produces a preset +3.3V or +2.5V output voltage or an adjustable output from +1.1V to V_{IN} . It achieves efficiencies as high as 95%.

The MAX1644 uses a unique current-mode, constant-off-time, PWM control scheme, which includes an Idle Mode^a to maintain high efficiency during light-load operation. The programmable constant-off-time architecture sets switching frequencies up to 350kHz, allowing the user to optimize performance trade-offs between efficiency, output switching noise, component size, and cost. The device also features an adjustable soft-start to limit surge currents during start-up, a 100% duty cycle mode for low-dropout operation, and a low-power shutdown mode that disconnects the input from the output and reduces supply current below $1\mu\text{A}$. The MAX1644 is available in a 16-pin SSOP package.

B. Absolute Maximum Ratings

| <u>Item</u> | <u>Rating</u> |
|---|------------------------------|
| V _{cc} , IN to GND | -0.3V to +6V |
| IN to V _{CC} | +/-0.3V |
| PGND to GND | +/-0.3V |
| LX to PGND | -0.3V to ($V_{IN} + 0.3V$) |
| All other Pins to GND | -0.3V to ($V_{CC} + 0.3V$) |
| Continuous LX Output Current | 2.5A |
| REF Short Circuit to GND Duration | Continuous |
| Storage Temp. | -65°C to +150°C |
| Lead Temp. (10 sec.) | +300°C |
| Continuous Power Dissipation ($T_A = +70^\circ\text{C}$) | |
| 16-Pin SSOP | 1.2W |
| Derates above +70°C (part mounted on 1 in ² of 1 oz. Copper) | |
| 16-Pin SSOP | 16.7mW/°C |

II. Manufacturing Information

- A. Description: 2A, Low-Voltage, Step-Down Regulator w/ Synchronous Rectification & Internal Switches
- B. Process: S12 (Standard 1.2 micron silicon gate CMOS)
- C. Number of Device Transistors: 1840
- D. Fabrication Location: Oregon or California, USA
- E. Assembly Location: Philippines
- F. Date of Initial Production: June, 1999

III. Packaging Information

- A. Package Type: **16-Lead SSOP**
- B. Lead Frame: Copper
- C. Lead Finish: Solder Plate
- D. Die Attach: Silver-filled Epoxy
- E. Bondwire: Gold (2.0 mil dia.)
- F. Mold Material: Epoxy with silica filler
- G. Assembly Diagram: Buildsheet # 05-1101-0105
- H. Flammability Rating: Class UL94-V0
- I. Classification of Moisture Sensitivity per JEDEC standard JESD22-A112: Level 1

IV. Die Information

- A. Dimensions: 121 x 132 mils
- B. Passivation: $\text{Si}_3\text{N}_4/\text{SiO}_2$ (Silicon nitride/ Silicon dioxide)
- C. Interconnect: Aluminum/Si (Si = 1%)
- D. Backside Metallization: None
- E. Minimum Metal Width: 1.2 microns (as drawn)
- F. Minimum Metal Spacing: 1.2 microns (as drawn)
- G. Bondpad Dimensions: 5 mil. Sq.
- H. Isolation Dielectric: SiO_2
- I. Die Separation Method: Wafer Saw

V. Quality Assurance Information

- A. Quality Assurance Contacts: Jim Pedicord (Reliability Lab Manager)
Bryan Preeshl (Executive Director of QA)
Kenneth Huening (Vice President)
- B. Outgoing Inspection Level: 0.1% for all electrical parameters guaranteed by the Datasheet.
0.1% For all Visual Defects.
- C. Observed Outgoing Defect Rate: < 50 ppm
- D. Sampling Plan: Mil-Std-105D

VI. Reliability Evaluation

A. Accelerated Life Test

The results of the 135°C biased (static) life test are shown in **Table 1**. Using these results, the Failure Rate (λ) is calculated as follows:

$$\lambda = \frac{1}{\text{MTTF}} = \frac{1.83}{192 \times 4389 \times 239 \times 2} \quad (\text{Chi square value for MTTF upper limit})$$

└ Temperature Acceleration factor assuming an activation energy of 0.8eV

$$\lambda = 4.54 \times 10^{-9} \quad \lambda = 4.54 \text{ F.I.T. (60\% confidence level @ 25°C)}$$

This low failure rate represents data collected from Maxim's reliability qualification and monitor programs. Maxim also performs weekly Burn-In on samples from production to assure reliability of its processes. The reliability required for lots which receive a burn-in qualification is 59 F.I.T. at a 60% confidence level, which equates to 3 failures in an 80 piece sample. Maxim performs failure analysis on rejects from lots exceeding this level. The attached Burn-In Schematic (Spec. # 06-5250) shows the static circuit used for this test. Maxim also performs 1000 hour life test monitors quarterly for each process. This data is published in the Product Reliability Report (**RR-1M**).

B. Moisture Resistance Tests

Maxim evaluates pressure pot stress from every assembly process during qualification of each new design. Pressure Pot testing must pass a 20% LTPD for acceptance. Additionally, industry standard 85°C/85%RH or HAST tests are performed quarterly per device/package family.

C. E.S.D. and Latch-Up Testing

The PX05 die type has been found to have all pins able to withstand a transient pulse of $\pm 1500\text{V}$, per Mil-Std-883 Method 3015 (reference attached ESD Test Circuit). Latch-Up testing has shown that this device withstands a current of $\pm 250\text{mA}$ and/or $\pm 20\text{V}$.

Table 1
Reliability Evaluation Test Results

MAX1644EAE

| TEST ITEM | TEST CONDITION | FAILURE IDENTIFICATION | SAMPLE SIZE | NUMBER OF FAILURES |
|-----------------------------------|---|----------------------------------|--------------------|---------------------------|
| Static Life Test (Note 1) | | | | |
| | Ta = 135°C Biased Time = 192 hrs. | DC Parameters & functionality | 239 | 0 |
| Moisture Testing (Note 2) | | | | |
| Pressure Pot | Ta = 121°C P = 15 psi. RH= 100% Time = 168hrs. | DC Parameters & functionality | 340 | 1 |
| 85/85 | Ta = 85°C RH = 85% Biased Time = 1000hrs. | DC Parameters & functionality | 77 | 0 |
| Mechanical Stress (Note 2) | | | | |
| Temperature Cycle | -65°C/150°C 1000 Cycles Method 1010 | DC Parameters | 77 | 0 |

Note 1: Life Test Data may represent plastic D.I.P. qualification lots for the Small Outline package.

Note 2: Generic Package/Process data

Attachment #1

TABLE II. Pin combination to be tested. 1/ 2/

| | Terminal A (Each pin individually connected to terminal A with the other floating) | Terminal B (The common combination of all like-named pins connected to terminal B) |
|----|---|---|
| 1. | All pins except V_{PS1} 3/ | All V_{PS1} pins |
| 2. | All input and output pins | All other input-output pins |

1/ Table II is restated in narrative form in 3.4 below.

2/ No connects are not to be tested.

3/ Repeat pin combination I for each named Power supply and for ground

(e.g., where V_{PS1} is V_{DD} , V_{CC} , V_{SS} , V_{BB} , GND, $+V_S$, $-V_S$, V_{REF} , etc).

3.4 Pin combinations to be tested.

- a. Each pin individually connected to terminal A with respect to the device ground pin(s) connected to terminal B. All pins except the one being tested and the ground pin(s) shall be open.
- b. Each pin individually connected to terminal A with respect to each different set of a combination of all named power supply pins (e.g., V_{SS1} , or V_{SS2} or V_{SS3} or V_{CC1} , or V_{CC2}) connected to terminal B. All pins except the one being tested and the power supply pin or set of pins shall be open.
- c. Each input and each output individually connected to terminal A with respect to a combination of all the other input and output pins connected to terminal B. All pins except the input or output pin being tested and the combination of all the other input and output pins shall be open.

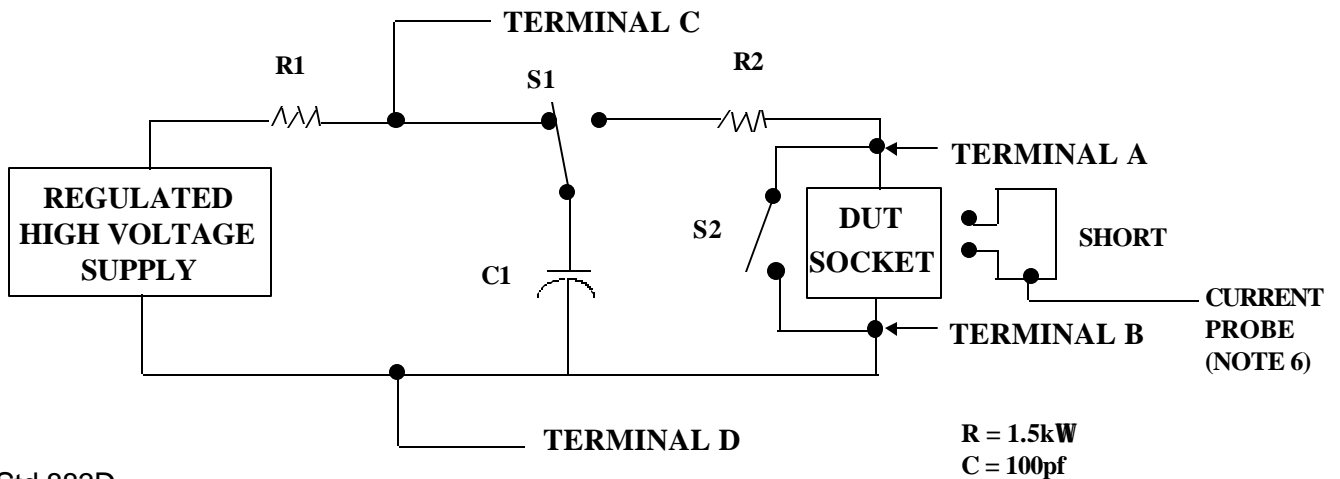

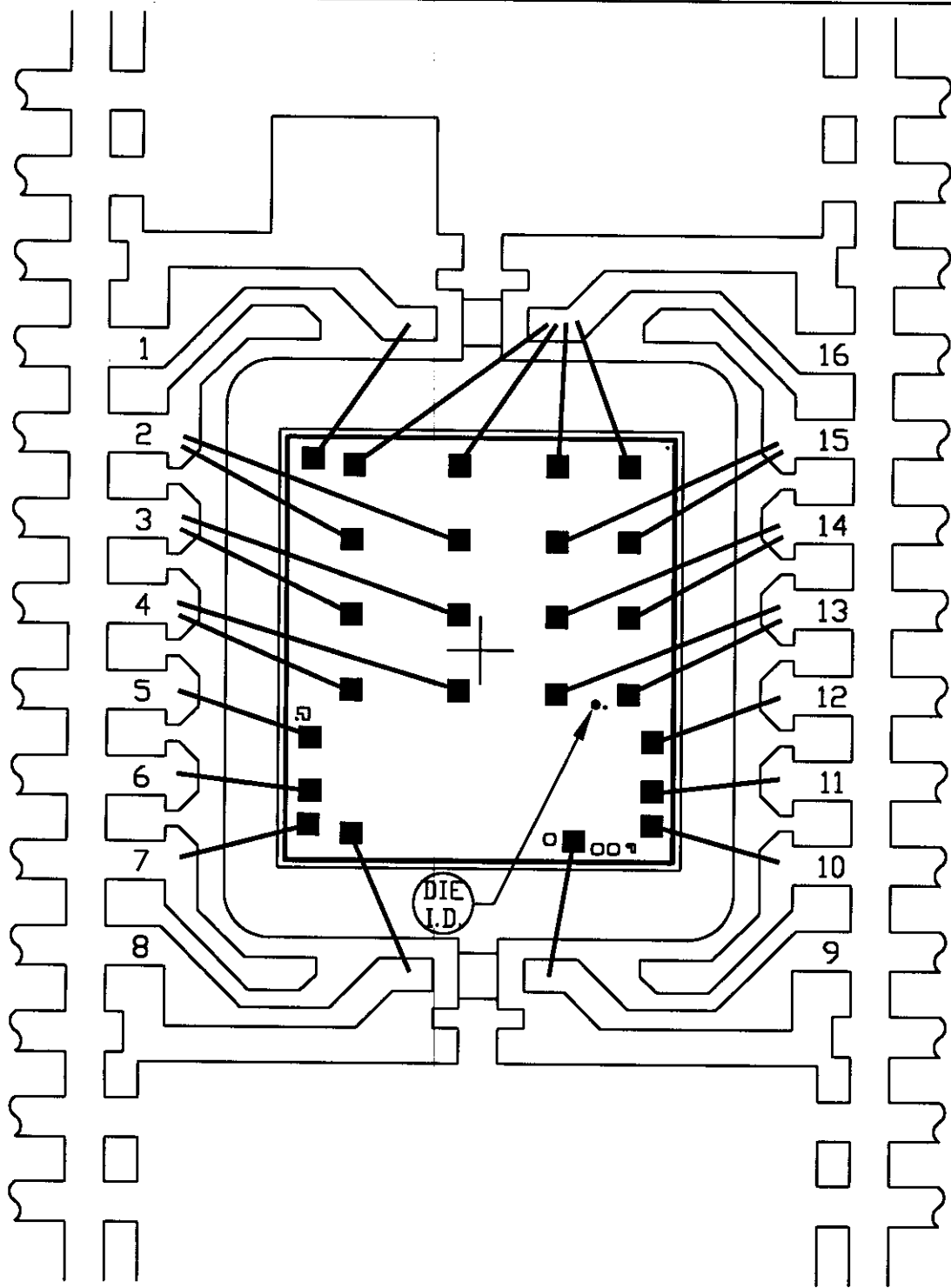

PKG.CODE: A16-2

CAV./PAD SIZE:
154X173

PKG.
DESIGN

APPROVALS

DATE

MAXIM

BUILDSHEET NUMBER:
05-1101-0105

REV:
B

ONCE PER BOARD

ONCE PER DEVICE

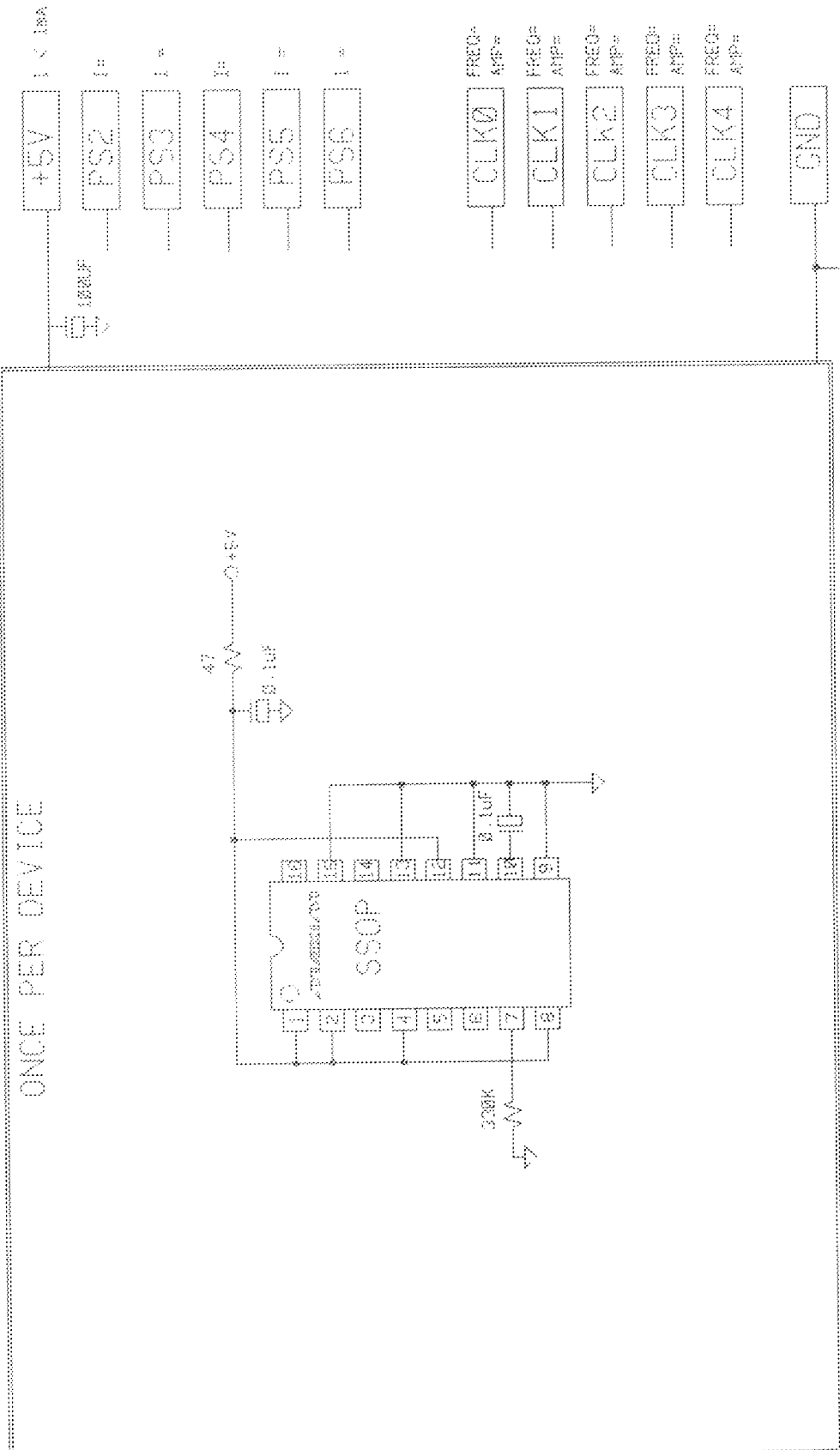

-- STEADY STATE LIFE TEST IS PER MIL-STD-883 METHOD JMMS
 -- BURN-IN IS PER MIL-STD-883 METHOD 1015, COND. 6

NOTES:

1. TEMPERATURE: 125C OR EQUIVALENT
2. TYPE: 160 HOURS RTH, OR EQUIVALENT
3. ALL COMPONENTS AND MATERIAL MUST STAND 155C CONTINUOUS
4. APPROVED FOR LXJ COMMERCIAL [X] HR-650

SPEC. NO. 06-5250 REV: A

MAXIM BURN-IN SCHEMATIC

DEVICE TYPE(G):

DATE: 11/1/96

MAX1644

DRAWN BY