



LBN10001 MHz SAW Filter Electrical Characteristic

Specifications

Parameter	Unit	Minimum	Typical	Maximum
Center Frequency	MHz	99.9	100	100.1
Insertion Loss	dB		27	29
3 dB Bandwidth	MHz	19.40	19.41	
30 dB Bandwidth	MHz		20.35	20.4
Passband variation	dB		1.0	1.5
Absolute Delay	usec		3.64	
Ultimate Rejection	dB	50	53	
Substrate Material		YZ LN		
Ambient Temperature	°C	25		
Package Size		DIP3512 (35.0x12.7x5.2mm ³)		

Typical Performance

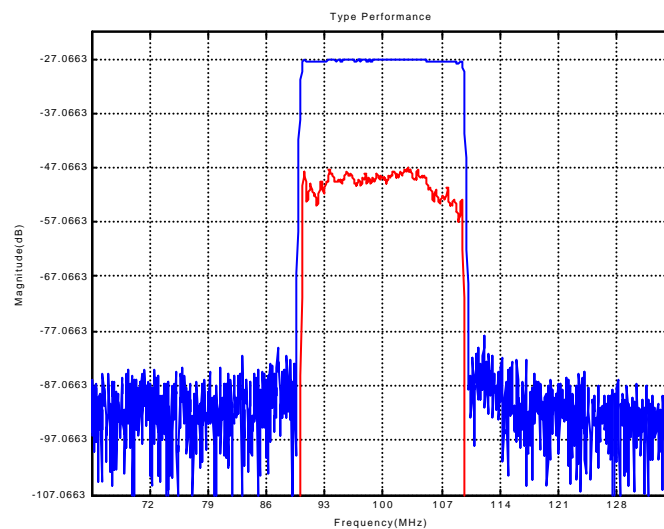

Package Outline

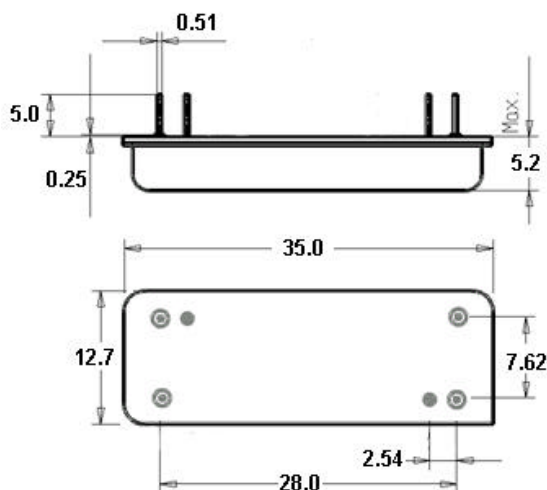

Matching Configuration

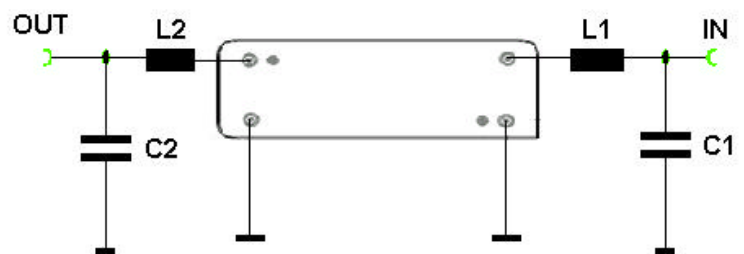

L1=56nH L2=120nH
 C1=C2=20pF

Source/Load Impedance = 50 ohm