

Heterojunction Bipolar Transistor Technology (InGaP HBT)

Broadband High Linearity Amplifier

The MMG3003NT1 is a General Purpose Amplifier that is internally input matched and internally output prematched. It is designed for a broad range of Class A, small-signal, high linearity, general purpose applications. It is suitable for applications with frequencies from 40 to 3600 MHz such as Cellular, PCS, BWA, WLL, PHS, CATV, VHF, UHF, UMTS and general small-signal RF.

Features

- Frequency: 40-3600 MHz
- P1dB: 24 dBm @ 900 MHz
- Small-Signal Gain: 20 dB @ 900 MHz
- Third Order Output Intercept Point: 40.5 dBm @ 900 MHz
- Single Voltage Supply
- Internally Matched to 50 Ohms
- Low Cost SOT-89 Surface Mount Package
- RoHS Compliant
- In Tape and Reel. T1 Suffix = 1000 Units per 12 mm, 7 inch Reel.

MMG3003NT1

**40-3600 MHz, 20 dB
 24 dBm
 InGaP HBT**

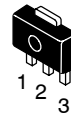

**CASE 1514-02, STYLE 1
 SOT-89
 PLASTIC**

NOT RECOMMENDED FOR NEW DESIGN

NOT RECOMMENDED FOR NEW DESIGN

Table 1. Typical Performance (1)

Characteristic	Symbol	900 MHz	2140 MHz	3500 MHz	Unit
Small-Signal Gain (S21)	G_p	20	16.9	12	dB
Input Return Loss (S11)	IRL	-15	-14.1	-11.2	dB
Output Return Loss (S22)	ORL	-9.3	-14.5	-10.2	dB
Power Output @1dB Compression	P1db	24	23.3	20.5	dBm
Third Order Output Intercept Point	IP3	40.5	40	37	dBm

1. $V_{CC} = 6.2$ Vdc, $T_C = 25^\circ\text{C}$, 50 ohm system

Table 2. Maximum Ratings

Rating	Symbol	Value	Unit
Supply Voltage	V_{CC}	7	V
Supply Current	I_{CC}	400	mA
RF Input Power	P_{in}	15	dBm
Storage Temperature Range	T_{stg}	-65 to +150	$^\circ\text{C}$
Junction Temperature (2)	T_J	150	$^\circ\text{C}$

2. For reliable operation, the junction temperature should not exceed 150°C .

Table 3. Thermal Characteristics ($V_{CC} = 6.2$ Vdc, $I_{CC} = 180$ mA, $T_C = 25^\circ\text{C}$)

Characteristic	Symbol	Value (3)	Unit
Thermal Resistance, Junction to Case	$R_{\theta JC}$	31.6	$^\circ\text{C}/\text{W}$

3. Refer to AN1955, *Thermal Measurement Methodology of RF Power Amplifiers*. Go to <http://www.freescale.com/rf>. Select Documentation/Application Notes - AN1955.

Table 4. Electrical Characteristics ($V_{CC} = 6.2$ Vdc, 900 MHz, $T_C = 25^\circ\text{C}$, 50 ohm system, in Freescale Application Circuit)

Characteristic	Symbol	Min	Typ	Max	Unit
Small-Signal Gain (S21)	G_p	19.3	20	—	dB
Input Return Loss (S11)	IRL	—	-15	—	dB
Output Return Loss (S22)	ORL	—	-9.3	—	dB
Power Output @ 1dB Compression	P1dB	—	24	—	dBm
Third Order Output Intercept Point	IP3	—	40.5	—	dBm
Noise Figure	NF	—	4	—	dB
Supply Current (1)	I_{CC}	160	180	205	mA
Supply Voltage (1)	V_{CC}	—	6.2	—	V

1. For reliable operation, the junction temperature should not exceed 150°C .

Table 5. Functional Pin Description

Pin Number	Pin Function
1	RF _{in}
2	Ground
3	RF _{out} /DC Supply

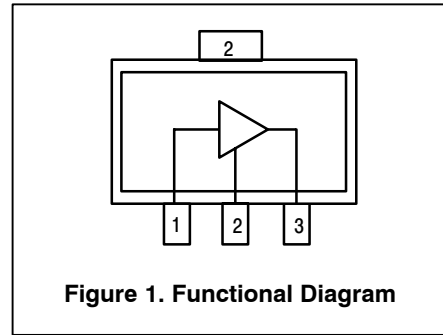

Figure 1. Functional Diagram

Table 6. ESD Protection Characteristics

Test Conditions/Test Methodology	Class
Human Body Model (per JESD 22-A114)	1B (Minimum)
Machine Model (per EIA/JESD 22-A115)	A (Minimum)
Charge Device Model (per JESD 22-C101)	IV (Minimum)

Table 7. Moisture Sensitivity Level

Test Methodology	Rating	Package Peak Temperature	Unit
Per JESD 22-A113, IPC/JEDEC J-STD-020	1	260	°C

50 OHM TYPICAL CHARACTERISTICS

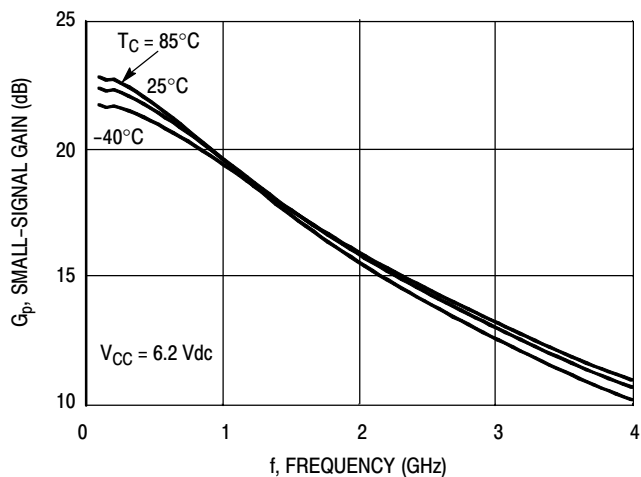

Figure 2. Small-Signal Gain (S21) versus Frequency

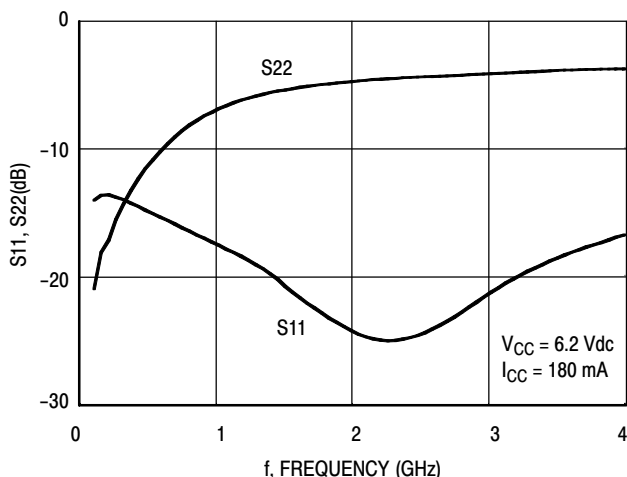

Figure 3. Input/Output Return Loss versus Frequency

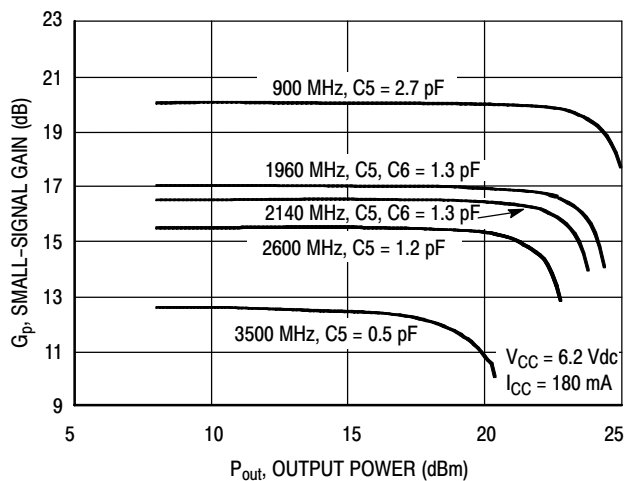

Figure 4. Small-Signal Gain versus Output Power

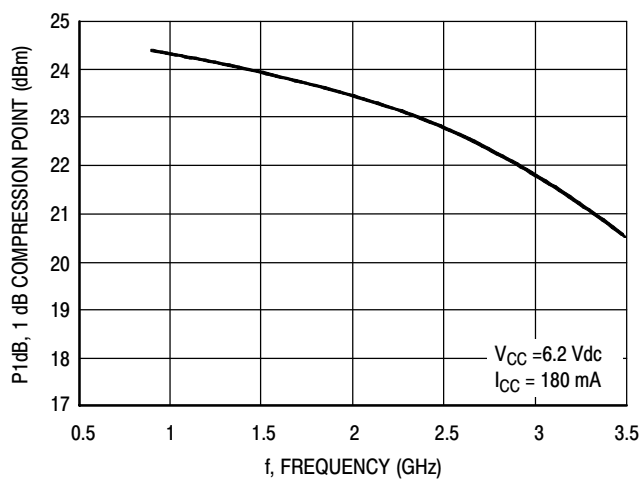

Figure 5. P1dB versus Frequency

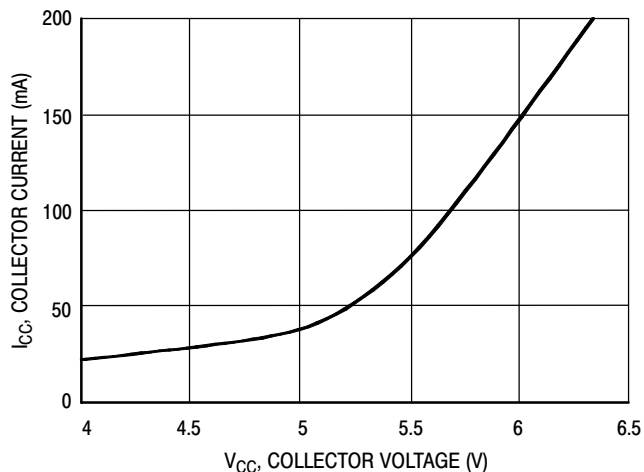

Figure 6. Collector Current versus Collector Voltage

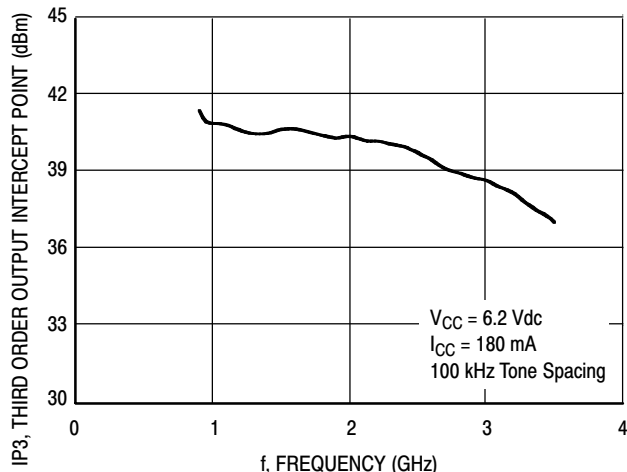

Figure 7. Third Order Output Intercept Point versus Frequency

NOT RECOMMENDED FOR NEW DESIGN

NOT RECOMMENDED FOR NEW DESIGN

50 OHM TYPICAL CHARACTERISTICS

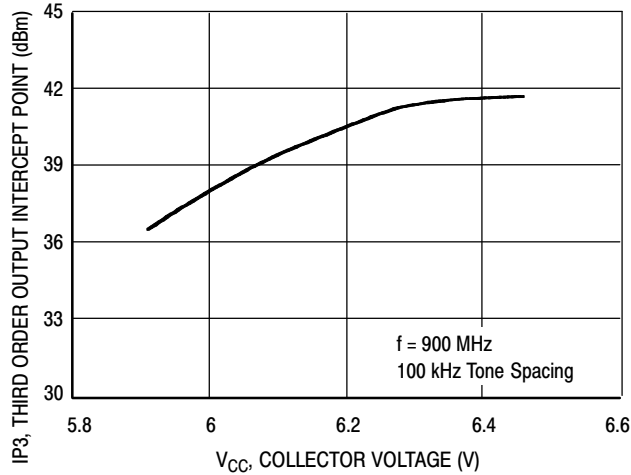

Figure 8. Third Order Output Intercept Point versus Collector Voltage

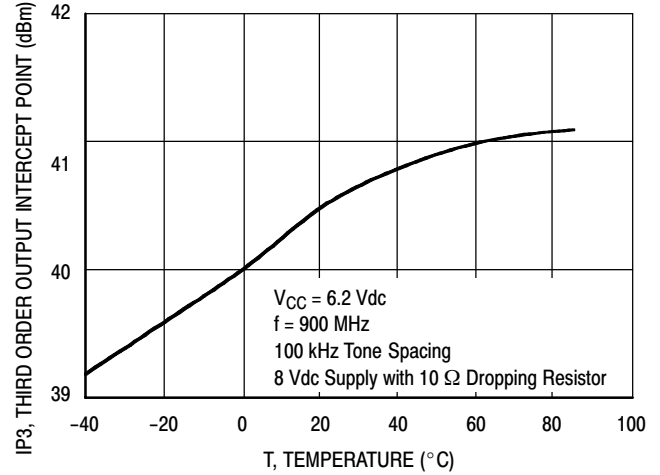

Figure 9. Third Order Output Intercept Point versus Case Temperature

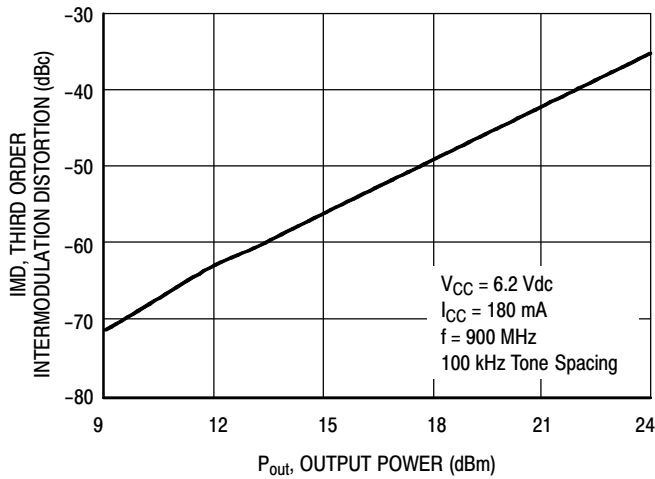

Figure 10. Third Order Intermodulation versus Output Power

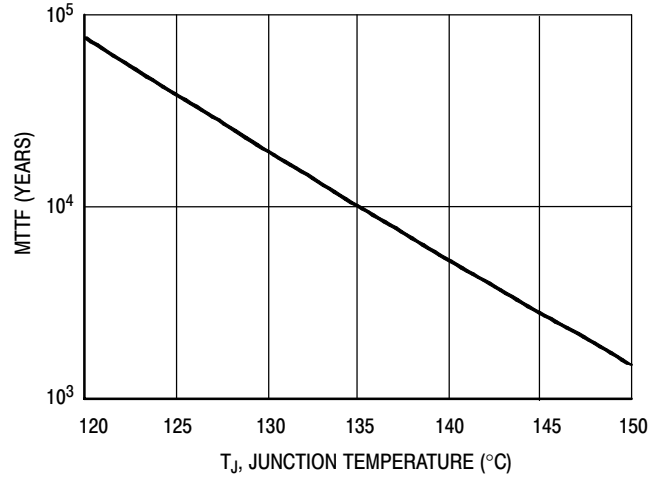

Figure 11. MTTF versus Junction Temperature
NOTE: The MTTF is calculated with $V_{CC} = 6.2$ Vdc, $I_{CC} = 180$ mA

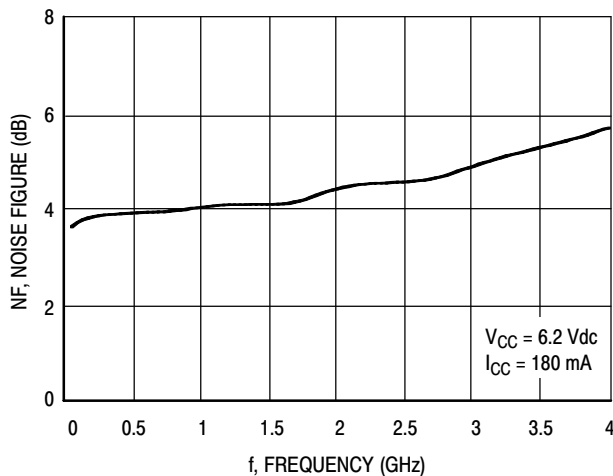

Figure 12. Noise Figure versus Frequency

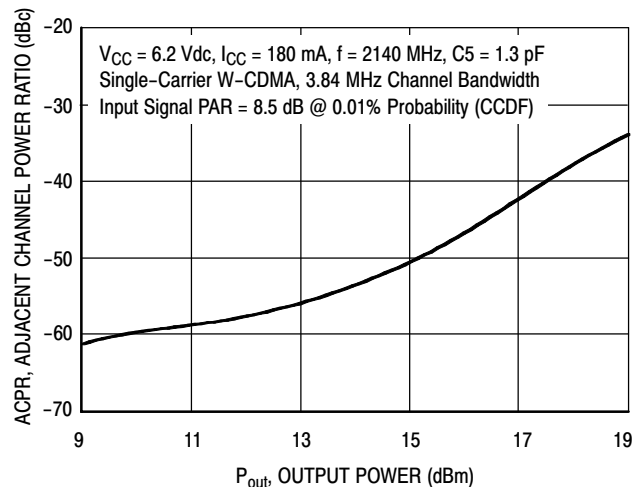

Figure 13. Single-Carrier W-CDMA Adjacent Channel Power Ratio versus Output Power

NOT RECOMMENDED FOR NEW DESIGN

NOT RECOMMENDED FOR NEW DESIGN

50 OHM APPLICATION CIRCUIT: 40-800 MHz

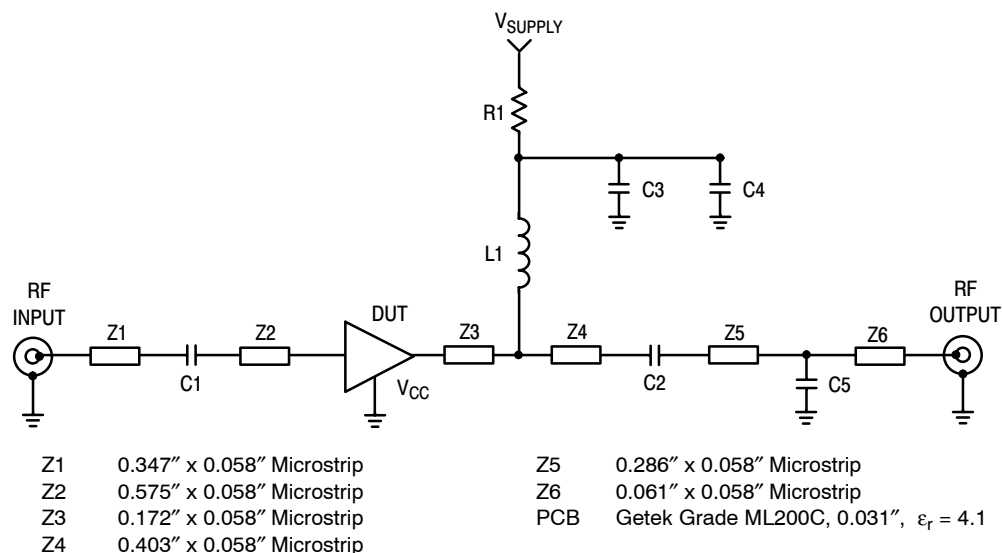

Figure 14. 50 Ohm Test Circuit Schematic

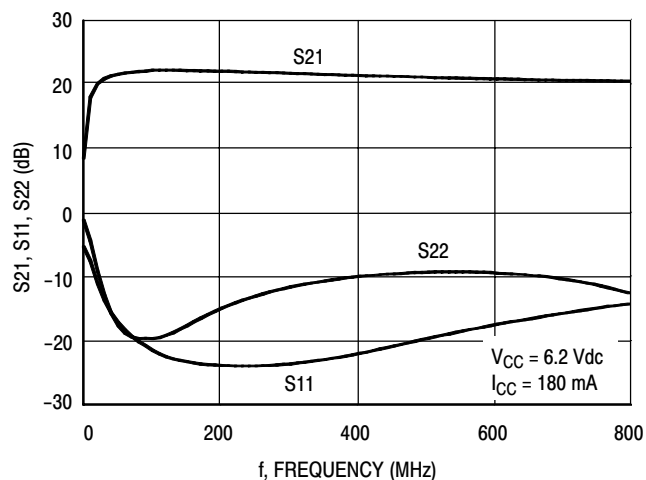

Figure 15. S21, S11 and S22 versus Frequency

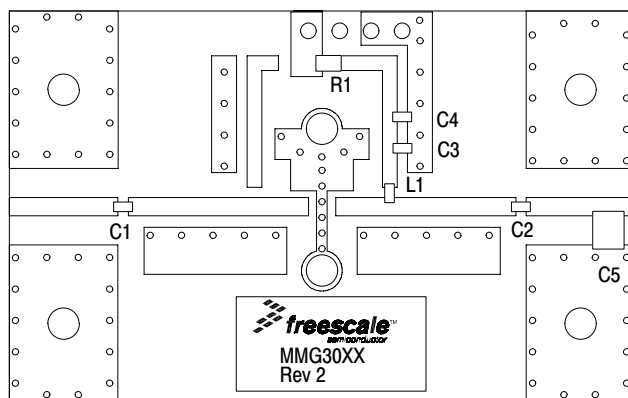

Figure 16. 50 Ohm Test Circuit Component Layout

Table 8. 50 Ohm Test Circuit Component Designations and Values

Part	Description	Part Number	Manufacturer
C1, C2, C4	0.01 μ F Chip Capacitors	C0603C103J5RAC	Kemet
C3	68 pF Chip Capacitor	C0805C680J5RAC	Kemet
C5 (1)	2.7 pF Chip Capacitor	12105J2R7BS	AVX
L1	470 nH Chip Inductor	BK2125HM471-T	Taiyo Yuden
R1	7.5 Ω Chip Resistor	RK73B2ATTE7R5J	KOA Speer

1. Tuning capacitor: Capacitor value and location on the transmission line are varied for different frequencies.

Table 9. Supply Voltage versus R1 Values

Supply Voltage	7	8	9	10	11	12	V
R1 Value	4.4	10	15.6	21	27	32	Ω

Note: To provide $V_{CC} = 6.2$ Vdc and $I_{CC} = 180$ mA at the device.

NOT RECOMMENDED FOR NEW DESIGN

NOT RECOMMENDED FOR NEW DESIGN

50 OHM APPLICATION CIRCUIT: 800-1100 MHz

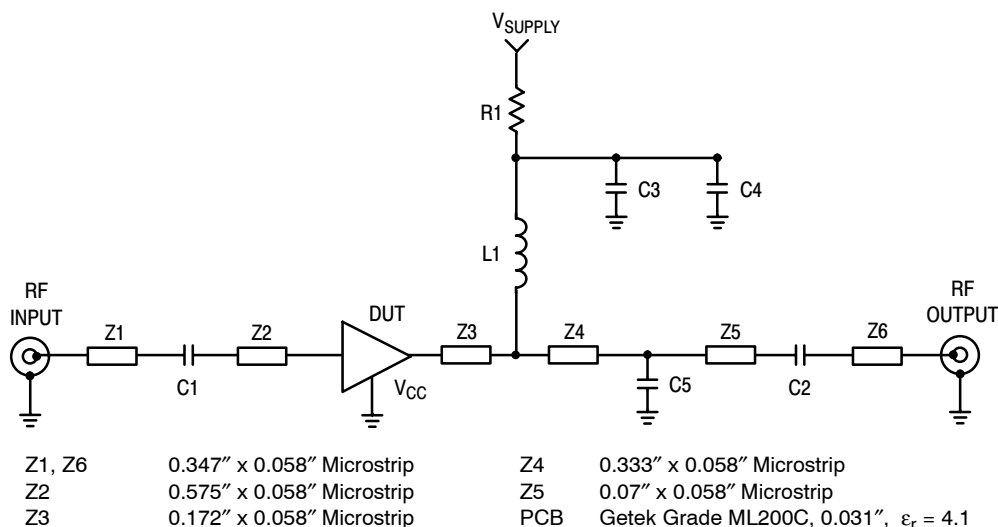

Figure 17. 50 Ohm Test Circuit Schematic

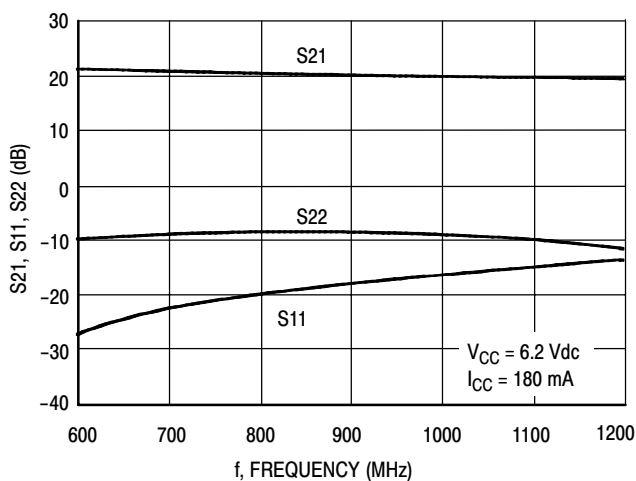

Figure 18. S21, S11 and S22 versus Frequency

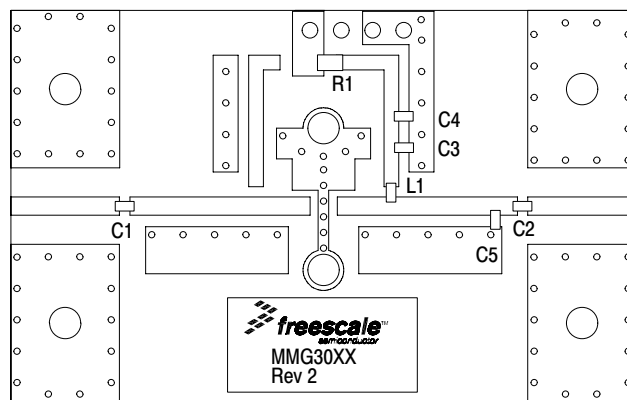

Figure 19. 50 Ohm Test Circuit Component Layout

Table 10. 50 Ohm Test Circuit Component Designations and Values

Part	Description	Part Number	Manufacturer
C1, C2	47 pF Chip Capacitors	C0805C470J5RAC	Kemet
C3	68 pF Chip Capacitor	C0805C680J5RAC	Kemet
C4	0.01 μ F Chip Capacitor	C0603C103J5RAC	Kemet
C5 (1)	2.7 pF Chip Capacitor	06035J2R7BS	AVX
L1	22 nH Chip Inductor	HK160822NJ-T	Taiyo Yuden
R1	7.5 Ω Chip Resistor	RK73B2ATTE7R5J	KOA Speer

1. Tuning capacitor: Capacitor value and location on the transmission line are varied for different frequencies.

50 OHM APPLICATION CIRCUIT: 1800-2400 MHz

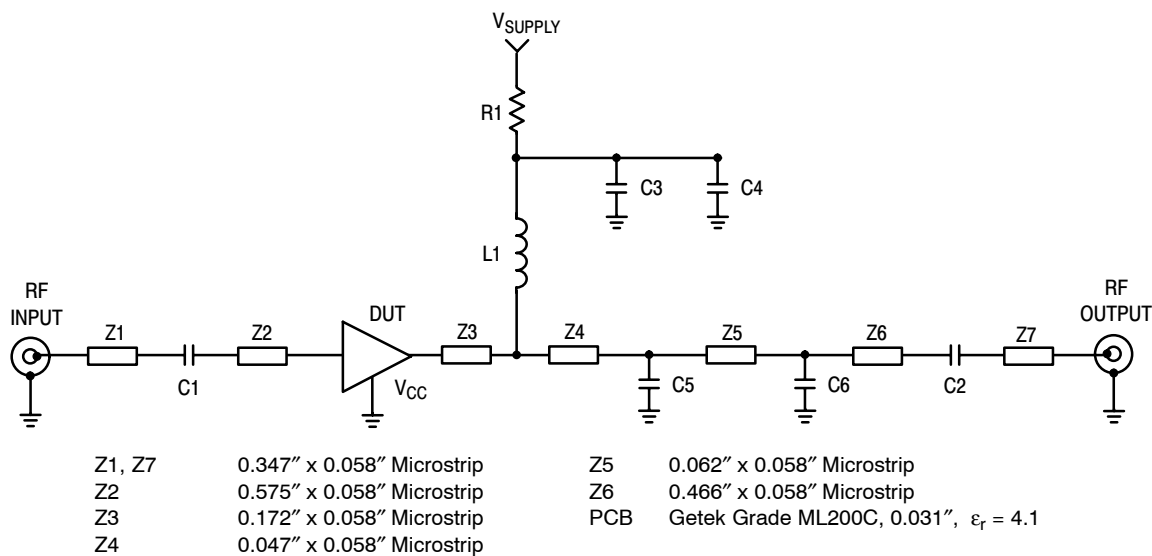

Figure 20. 50 Ohm Test Circuit Schematic

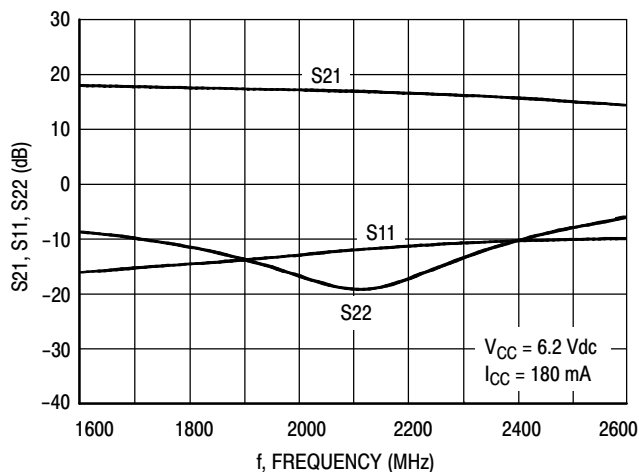

Figure 21. S21, S11 and S22 versus Frequency

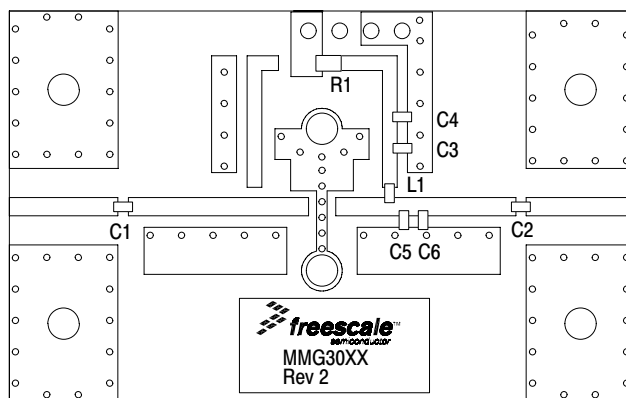

Figure 22. 50 Ohm Test Circuit Component Layout

Table 11. 50 Ohm Test Circuit Component Designations and Values

Part	Description	Part Number	Manufacturer
C1, C2	47 pF Chip Capacitors	C0805C470J5RAC	Kemet
C3	68 pF Chip Capacitor	C0805C680J5RAC	Kemet
C4	0.01 μ F Chip Capacitor	C0603C103J5RAC	Kemet
C5 (1)	1.2 pF Chip Capacitor	06035J1R2BS	AVX
C6 (1)	0.1 pF Chip Capacitor	06035J0R1BS	AVX
L1	22 nH Chip Inductor	HK160822NJ-T	Taiyo Yuden
R1	7.5 Ω Chip Resistor	RK73B2ATTE7R5J	KOA Speer

1. Tuning capacitor: Capacitor value and location on the transmission line are varied for different frequencies.

NOT RECOMMENDED FOR NEW DESIGN

NOT RECOMMENDED FOR NEW DESIGN

50 OHM APPLICATION CIRCUIT: 2500-2700 MHz

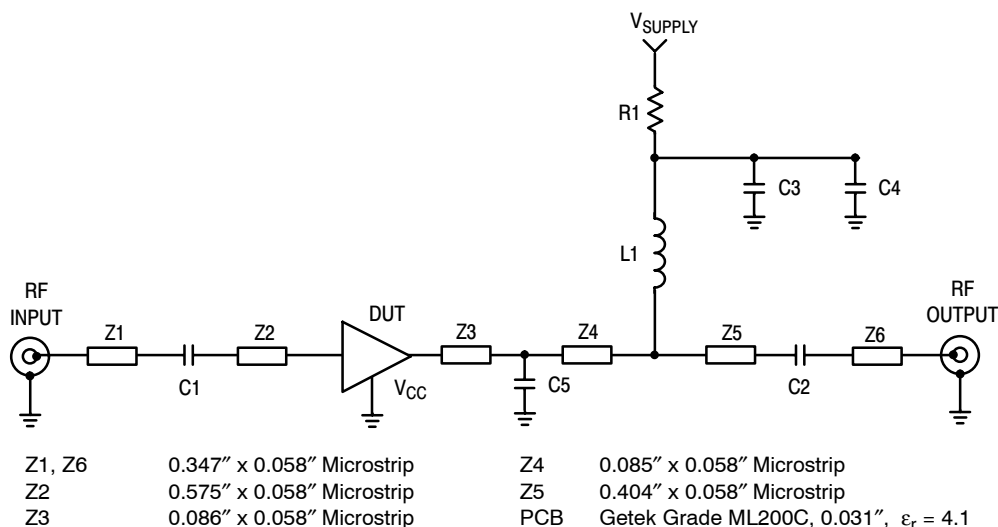

Figure 23. 50 Ohm Test Circuit Schematic

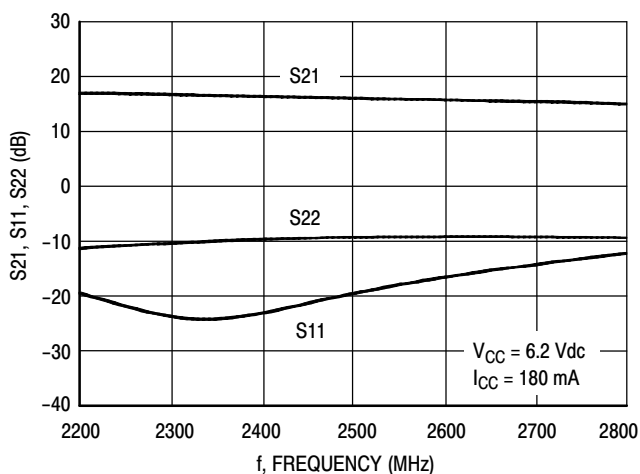

Figure 24. S21, S11 and S22 versus Frequency

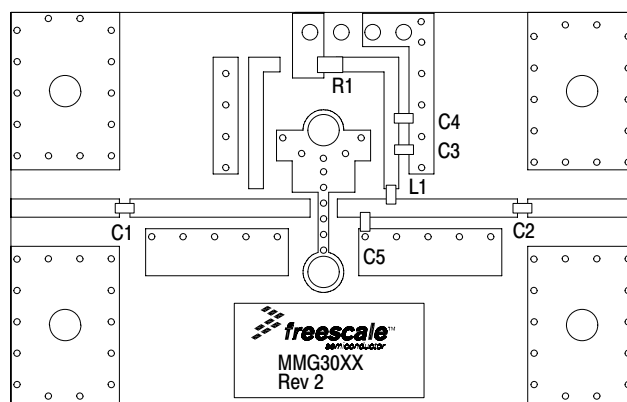

Figure 25. 50 Ohm Test Circuit Component Layout

Table 12. 50 Ohm Test Circuit Component Designations and Values

Part	Description	Part Number	Manufacturer
C1, C2	2.2 pF Chip Capacitors	06035J2R2BS	AVX
C3	68 pF Chip Capacitor	C0805C680J5RAC	Kemet
C4	0.01 μ F Chip Capacitor	C0603C103J5RAC	Kemet
C5 (1)	1.2 pF Chip Capacitor	06035J1R2BS	AVX
L1	39 nH Chip Inductor	HK160839NJ-T	Taiyo Yuden
R1	7.5 Ω Chip Resistor	RK73B2ATTE7R5J	KOA Speer

1. Tuning capacitor: Capacitor value and location on the transmission line are varied for different frequencies.

NOT RECOMMENDED FOR NEW DESIGN

NOT RECOMMENDED FOR NEW DESIGN

50 OHM APPLICATION CIRCUIT: 3400-3600 MHz

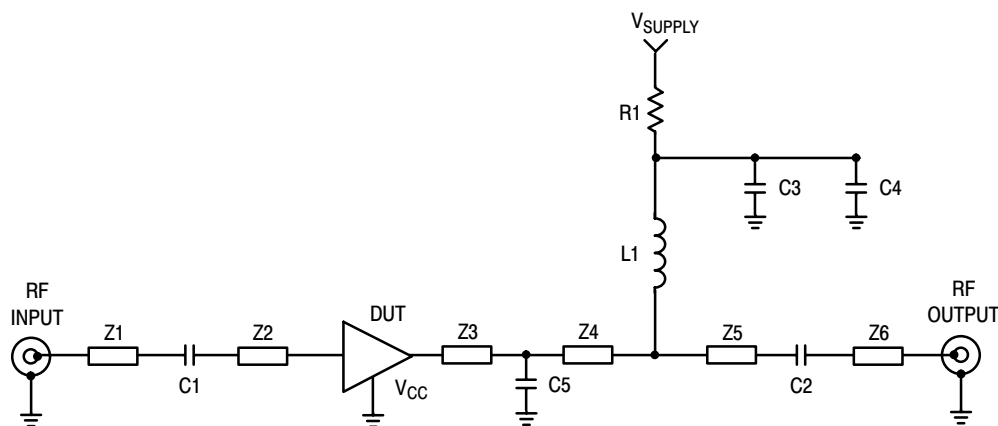

Z1, Z6	0.347" x 0.058" Microstrip	Z4	0.085" x 0.058" Microstrip
Z2	0.575" x 0.058" Microstrip	Z5	0.404" x 0.058" Microstrip
Z3	0.086" x 0.058" Microstrip	PCB	Getek Grade ML200C, 0.031", $\epsilon_r = 4.1$

Figure 26. 50 Ohm Test Circuit Schematic

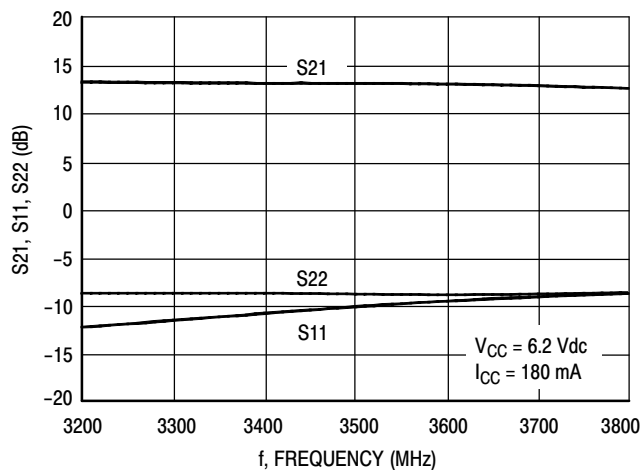

Figure 27. S21, S11 and S22 versus Frequency

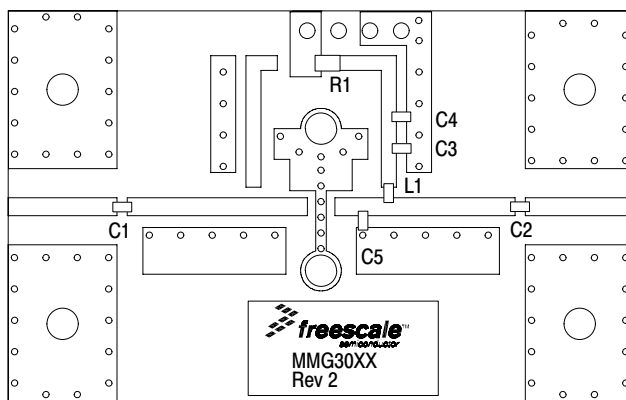

Figure 28. 50 Ohm Test Circuit Component Layout

Table 13. 50 Ohm Test Circuit Component Designations and Values

Part	Description	Part Number	Manufacturer
C1, C2	2.2 pF Chip Capacitors	06035J2R2BS	AVX
C3	68 pF Chip Capacitor	C0805C680J5RAC	Kemet
C4	0.01 μF Chip Capacitor	C0603C103J5RAC	Kemet
C5 (1)	0.5 pF Chip Capacitor	06035J0R5BS	AVX
L1	39 nH Chip Inductor	HK160839NJ-T	Taiyo Yuden
R1	7.5 Ω Chip Resistor	RK73B2ATTE7R5J	KOA Speer

1. Tuning capacitor: Capacitor value and location on the transmission line are varied for different frequencies.

50 OHM TYPICAL CHARACTERISTICS

Table 14. Common Emitter S-Parameters ($V_{CC} = 6.2 \text{ Vdc}$, $I_{CC} = 180 \text{ mA}$, $T_C = 25^\circ\text{C}$, 50 Ohm System)

f MHz	S ₁₁		S ₂₁		S ₁₂		S ₂₂	
	S ₁₁	∠ φ	S ₂₁	∠ φ	S ₁₂	∠ φ	S ₂₂	∠ φ
0100	0.141	178.297	12.985	173.850	0.057	0.785	0.087	-167.704
0150	0.153	175.556	12.654	168.9	0.057	-0.913	0.136	-137.479
0200	0.155	160.177	13.067	164.046	0.059	-2.423	0.125	-131.397
0250	0.152	159.068	12.851	160.334	0.058	-2.897	0.159	-130.233
0300	0.147	156.309	12.685	156.518	0.058	-3.227	0.187	-128.649
0350	0.139	153.853	12.519	152.664	0.058	-3.971	0.212	-128.651
0400	0.135	150.838	12.327	149.087	0.057	-4.471	0.239	-129.263
0450	0.129	148.378	12.124	145.521	0.057	-4.799	0.263	-130.237
0500	0.123	145.160	11.915	142.009	0.057	-5.285	0.285	-131.637
0550	0.117	142.332	11.694	138.634	0.057	-5.623	0.306	-133.294
0600	0.112	139.364	11.470	135.366	0.057	-6.012	0.326	-135.284
0650	0.106	136.769	11.238	132.093	0.057	-6.295	0.345	-137.146
0700	0.101	133.592	11.004	128.948	0.057	-6.705	0.362	-139.07
0750	0.096	131.187	10.770	125.882	0.057	-7.044	0.378	-141.171
0800	0.090	128.979	10.532	122.88	0.056	-7.277	0.394	-143.273
0850	0.086	126.711	10.298	119.942	0.056	-7.495	0.408	-145.372
0900	0.081	124.541	10.066	117.117	0.056	-7.847	0.422	-147.618
0950	0.076	122.189	9.841	114.276	0.056	-8.05	0.435	-149.849
1000	0.073	121.191	9.611	111.625	0.056	-8.311	0.447	-151.947
1050	0.069	119.451	9.393	108.992	0.056	-8.582	0.458	-154.142
1100	0.065	118.827	9.170	106.412	0.056	-8.89	0.470	-156.289
1150	0.062	118.851	8.957	103.879	0.056	-9.079	0.480	-158.481
1200	0.059	118.882	8.742	101.417	0.056	-9.405	0.490	-160.544
1250	0.056	119.703	8.541	99.039	0.056	-9.615	0.498	-162.608
1300	0.054	120.919	8.340	96.664	0.056	-9.805	0.507	-164.561
1350	0.051	123.223	8.143	94.364	0.056	-10.198	0.515	-166.501
1400	0.048	125.019	7.957	92.107	0.056	-10.536	0.522	-168.351
1450	0.046	128.063	7.774	89.892	0.056	-10.724	0.530	-170.229
1500	0.033	135.869	7.640	87.599	0.057	-11.197	0.529	-172.918
1550	0.030	139.127	7.475	85.482	0.057	-11.434	0.536	-174.487
1600	0.027	142.585	7.322	83.442	0.057	-11.649	0.541	-175.93
1650	0.024	146.640	7.170	81.444	0.057	-11.993	0.546	-177.394
1700	0.023	152.580	7.040	79.397	0.058	-12.335	0.552	-179.018
1750	0.021	158.266	6.890	77.439	0.058	-12.616	0.555	179.899
1800	0.021	166.196	6.756	75.477	0.058	-12.879	0.560	178.582
1850	0.022	171.633	6.621	73.576	0.058	-13.16	0.563	177.318
1900	0.023	177.431	6.495	71.695	0.058	-13.445	0.566	176.139
1950	0.025	-176.142	6.371	69.952	0.059	-13.806	0.570	175.08
2000	0.027	-173.137	6.251	67.988	0.059	-14.176	0.573	173.812
2050	0.029	-170.367	6.135	66.175	0.059	-14.413	0.577	172.704
2100	0.031	-168.467	6.025	64.385	0.060	-14.882	0.580	171.566
2150	0.033	-168.388	5.921	62.595	0.060	-15.338	0.583	170.426
2200	0.036	-169.515	5.815	60.823	0.060	-15.659	0.586	169.283
2250	0.039	-170.197	5.716	59.079	0.061	-16.136	0.589	168.164

(continued)

NOT RECOMMENDED FOR NEW DESIGN

NOT RECOMMENDED FOR NEW DESIGN

50 OHM TYPICAL CHARACTERISTICS

Table 14. Common Emitter S-Parameters ($V_{CC} = 6.2$ Vdc, $I_{CC} = 180$ mA, $T_C = 25^\circ\text{C}$, 50 Ohm System) (continued)

f MHz	S ₁₁		S ₂₁		S ₁₂		S ₂₂	
	S ₁₁	∠ φ	S ₂₁	∠ φ	S ₁₂	∠ φ	S ₂₂	∠ φ
2300	0.042	-171.944	5.618	57.331	0.061	-16.513	0.591	167.003
2350	0.045	-173.747	5.525	55.573	0.061	-16.98	0.593	165.803
2400	0.048	-175.268	5.431	53.848	0.062	-17.435	0.595	164.669
2450	0.052	-177.409	5.345	52.136	0.062	-17.955	0.597	163.447
2500	0.056	-178.703	5.258	50.405	0.062	-18.404	0.598	162.182
2550	0.060	179.650	5.173	48.736	0.063	-19.004	0.600	160.854
2600	0.063	177.705	5.096	47.012	0.063	-19.505	0.602	159.516
2650	0.067	175.894	5.015	45.266	0.063	-20.1	0.603	158.1
2700	0.071	174.932	4.938	43.452	0.064	-20.75	0.605	156.649
2750	0.074	172.453	4.861	41.831	0.064	-21.297	0.607	155.174
2800	0.079	170.595	4.788	40.113	0.065	-21.999	0.609	153.675
2850	0.083	168.962	4.715	38.402	0.065	-22.577	0.610	152.104
2900	0.087	167.373	4.643	36.711	0.065	-23.239	0.612	150.539
2950	0.091	165.543	4.573	35.036	0.066	-23.942	0.614	148.941
3000	0.095	164.513	4.506	33.356	0.066	-24.652	0.616	147.251
3050	0.099	163.309	4.438	31.684	0.066	-25.269	0.618	145.747
3100	0.103	162.077	4.373	29.98	0.067	-26.085	0.620	144.105
3150	0.107	161.249	4.308	28.307	0.067	-26.717	0.622	142.483
3200	0.110	160.222	4.244	26.653	0.067	-27.483	0.624	140.894
3250	0.114	159.057	4.182	25.007	0.068	-28.223	0.626	139.31
3300	0.117	158.018	4.121	23.381	0.068	-29.013	0.629	137.737
3350	0.119	156.94	4.061	21.791	0.068	-29.779	0.631	136.267
3400	0.122	155.757	4.004	20.196	0.069	-30.535	0.633	134.76
3450	0.126	154.754	3.949	18.618	0.069	-31.29	0.635	6
3500	0.12826	153.898	3.895	17.049	0.06938	-31.957	0.6367	131.951
3550	0.13168	152.875	3.84045	15.491	0.06971	-32.814	0.6392	130.655
3600	0.13497	152.157	3.78882	13.97	0.07016	-33.474	0.64031	129.412

NOT RECOMMENDED FOR NEW DESIGN

NOT RECOMMENDED FOR NEW DESIGN

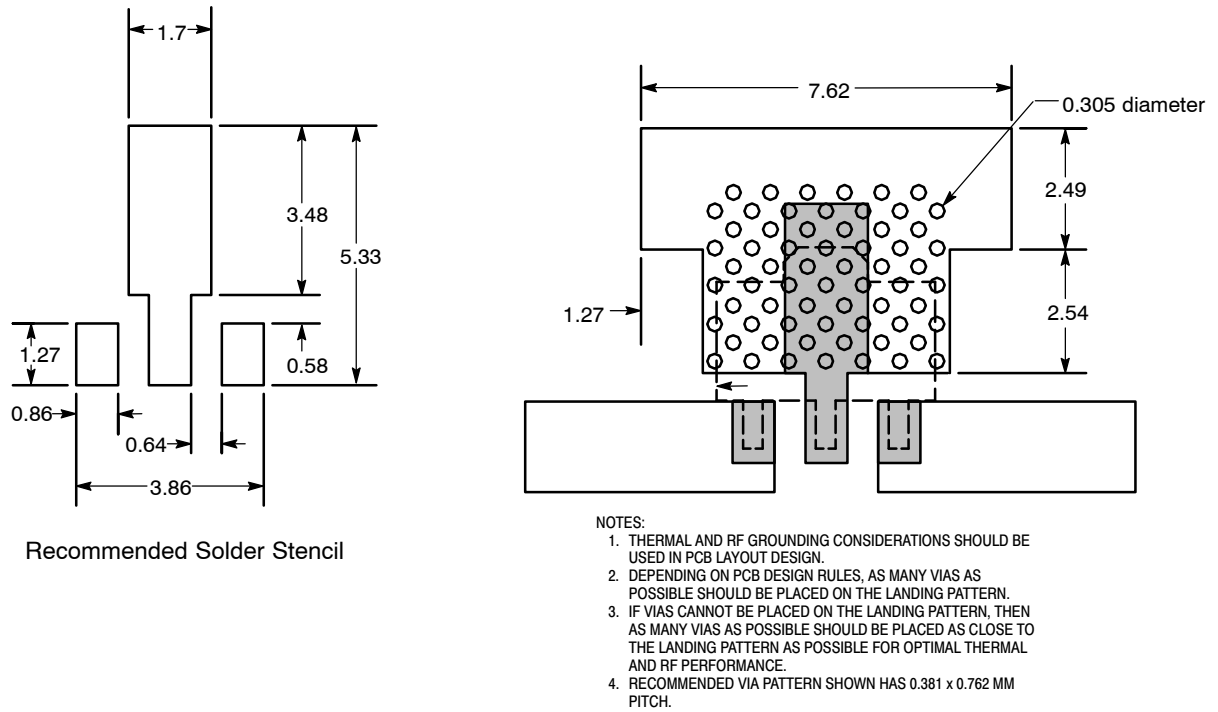
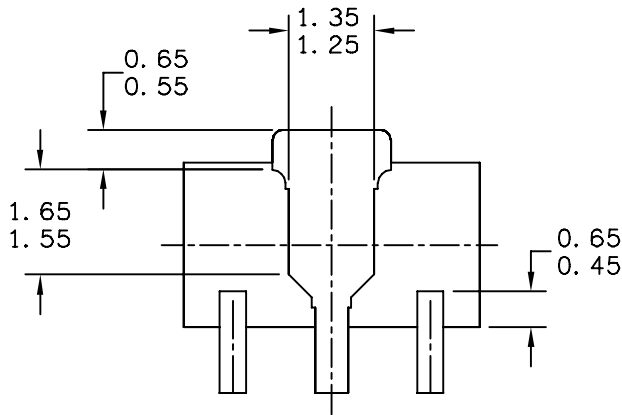

Figure 29. Recommended Mounting Configuration



BOTTOM VIEW

CASE STYLE:

STYLE 1:

- PIN 1. RF INPUT
- PIN 2. GROUND
- PIN 3. RF OUTPUT

STYLE 2:

- PIN 1. GATE
- PIN 2. SOURCE
- PIN 3. DRAIN

© FREESCALE SEMICONDUCTOR, INC. ALL RIGHTS RESERVED.	MECHANICAL OUTLINE	PRINT VERSION NOT TO SCALE	
TITLE: SOT-89, 4 LEAD, 4.5 X 2.5 PKG, 1.5 MM PITCH	DOCUMENT NO: 98ASA10586D	REV: D	
	CASE NUMBER: 1514-02	27 JUN 2007	
	STANDARD: NON-JEDEC		

NOTES:

- 1 DIMENSIONING AND TOLERANCING PER ASME Y14.5M – 1994.
- 2 ALL DIMENSIONS ARE IN MILLIMETERS.
- 3 DIMENSIONS DOES NOT INCLUDE MOLD FLASH. PROTRUSIONS OR GATE BURRS. MOLD FLASH, PROTRUSIONS OR GATE BURRS SHALL NOT EXCEED 0.5mm PER END. DIMENSION DOES NOT INCLUDE INTERLEAD FLASH OR PROTRUSION. INTERLEAD FLASH OR PROTRUSION SHALL NOT EXCEED 0.5 mm PER SIDE.
- 4 DIMENSION ARE DETERMINED AT THE OUTMOST EXTREMES OF THE PLASTIC BODY EXCLUSIVE OF MOLD FLASH, TIE BAR BURRS, GATE BURRS AND INTERLEAD FLASH, BUT INCLUDING ANY MISMATCH BETWEEN THE TOP AND BOTTOM OF THE PLASTIC BODY.
- 5 TERMINAL NUMBERS ARE SHOWN FOR REFERENCE ONLY.

© FREESCALE SEMICONDUCTOR, INC. ALL RIGHTS RESERVED.	MECHANICAL OUTLINE	PRINT VERSION NOT TO SCALE	
TITLE: SOT-89, 4 LEAD, 4.5 X 2.5 PKG, 1.5 MM PITCH	DOCUMENT NO: 98ASA10586D	REV: D	
	CASE NUMBER: 1514-02	27 JUN 2007	
	STANDARD: NON-JEDEC		

PRODUCT DOCUMENTATION

Refer to the following documents to aid your design process.

Application Notes

- AN1955: Thermal Measurement Methodology of RF Power Amplifiers
- AN3100: General Purpose Amplifier Biasing

REVISION HISTORY

The following table summarizes revisions to this document.

Revision	Date	Description
5	Mar. 2007	<ul style="list-style-type: none">• Corrected and updated Part Numbers in Tables 8, 10, 11, 12, and 13, Component Designations and Values, to RoHS compliant part numbers, p. 6-10
6	July 2007	<ul style="list-style-type: none">• Replaced Case Outline 1514-01 with 1514-02, Issue D, p. 1, 14-16. Case updated to add missing dimension for Pin 1 and Pin 3.
7	Mar. 2008	<ul style="list-style-type: none">• Removed Footnote 2, Continuous voltage and current applied to device, from Table 2, Maximum Ratings, p. 1• Corrected Fig. 13, Single-Carrier W-CDMA Adjacent Channel Power Ratio versus Output Power y-axis (ACPR) unit of measure to dBc, p. 5• Corrected S-Parameter table frequency column label to read "MHz" versus "GHz" and corrected frequency values from GHz to MHz, p. 11, 12

NOT RECOMMENDED FOR NEW DESIGN

NOT RECOMMENDED FOR NEW DESIGN

How to Reach Us:**Home Page:**

www.freescale.com

Web Support:

<http://www.freescale.com/support>

USA/Europe or Locations Not Listed:

Freescale Semiconductor, Inc.
Technical Information Center, EL516
2100 East Elliot Road
Tempe, Arizona 85284
+1-800-521-6274 or +1-480-768-2130
www.freescale.com/support

Europe, Middle East, and Africa:

Freescale Halbleiter Deutschland GmbH
Technical Information Center
Schatzbogen 7
81829 Muenchen, Germany
+44 1296 380 456 (English)
+46 8 52200080 (English)
+49 89 92103 559 (German)
+33 1 69 35 48 48 (French)
www.freescale.com/support

Japan:

Freescale Semiconductor Japan Ltd.
Headquarters
ARCO Tower 15F
1-8-1, Shimo-Meguro, Meguro-ku,
Tokyo 153-0064
Japan
0120 191014 or +81 3 5437 9125
support.japan@freescale.com

Asia/Pacific:

Freescale Semiconductor China Ltd.
Exchange Building 23F
No. 118 Jianguo Road
Chaoyang District
Beijing 100022
China
+86 010 5879 8000
support.asia@freescale.com

For Literature Requests Only:

Freescale Semiconductor Literature Distribution Center
P.O. Box 5405
Denver, Colorado 80217
1-800-441-2447 or 303-675-2140
Fax: 303-675-2150
LDCForFreescaleSemiconductor@hibbertgroup.com

Information in this document is provided solely to enable system and software implementers to use Freescale Semiconductor products. There are no express or implied copyright licenses granted hereunder to design or fabricate any integrated circuits or integrated circuits based on the information in this document.

Freescale Semiconductor reserves the right to make changes without further notice to any products herein. Freescale Semiconductor makes no warranty, representation or guarantee regarding the suitability of its products for any particular purpose, nor does Freescale Semiconductor assume any liability arising out of the application or use of any product or circuit, and specifically disclaims any and all liability, including without limitation consequential or incidental damages. "Typical" parameters that may be provided in Freescale Semiconductor data sheets and/or specifications can and do vary in different applications and actual performance may vary over time. All operating parameters, including "Typicals", must be validated for each customer application by customer's technical experts. Freescale Semiconductor does not convey any license under its patent rights nor the rights of others. Freescale Semiconductor products are not designed, intended, or authorized for use as components in systems intended for surgical implant into the body, or other applications intended to support or sustain life, or for any other application in which the failure of the Freescale Semiconductor product could create a situation where personal injury or death may occur. Should Buyer purchase or use Freescale Semiconductor products for any such unintended or unauthorized application, Buyer shall indemnify and hold Freescale Semiconductor and its officers, employees, subsidiaries, affiliates, and distributors harmless against all claims, costs, damages, and expenses, and reasonable attorney fees arising out of, directly or indirectly, any claim of personal injury or death associated with such unintended or unauthorized use, even if such claim alleges that Freescale Semiconductor was negligent regarding the design or manufacture of the part.

Freescale™ and the Freescale logo are trademarks of Freescale Semiconductor, Inc. All other product or service names are the property of their respective owners.

© Freescale Semiconductor, Inc. 2004-2008. All rights reserved.

