

Aluminum Capacitors Power Printed Wiring Style

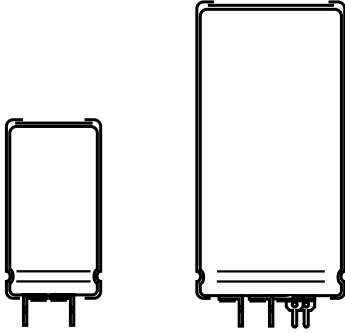

Component outlines

QUICK REFERENCE DATA		
DESCRIPTION	VALUE	
	≤ 100 V	> 100 V
Nominal case size (Ø D x L in mm)	25 x 30 to 40 x 100	
Rated capacitance range (E6 series), C _R	680 µF to 150 000 µF	68 µF to 2200 µF
Tolerance on C _R	± 20 %	
Rated voltage range, U _R	10 V to 100 V	200 V to 400 V
Category temperature range	- 40 °C to + 85 °C	
Endurance test at 85 °C	5000 h	
Useful life at 85 °C	12 000 h	
Useful life at 40 °C, 1.4 x I _R applied	190 000 h	
Shelf life at 0 V, 85 °C	500 h	
Based on sectional specification	IEC 60384-4/EN130300	
Climatic category IEC 60068	40/085/56	

FEATURES

- Polarized aluminum electrolytic capacitors, non-solid electrolyte
- Large types with reduced dimensions, cylindrical aluminum case, insulated
- Provided with keyed polarity
- Long useful life: 12 000 h at 85 °C
- High ripple current capability
- High resistance to shock and vibration

**RoHS
COMPLIANT**
APPLICATIONS

- General purpose, industrial and audio/video systems
- Smoothing and filtering
- Standard and switched mode power supplies
- Energy storage in pulse systems

MARKING

The capacitors are marked (where possible) with the following information:

- Rated capacitance (in µF)
- Tolerance on rated capacitance, code letter in accordance with IEC 60062 (M for ± 20 %)
- Rated voltage (in V)
- Date code (YYMM)
- Name of manufacturer
- Code for factory of origin
- Polarity of the terminals and '-' sign to indicate the negative terminal, visible from the top and/or side of the capacitor
- Code number
- Climatic category in accordance with IEC 60068

SELECTION CHART FOR C _R , U _R AND RELEVANT NOMINAL CASE SIZES (Ø D x L in mm)									
C _R (µF)	U _R (V)								
	10	16	25	40	63	100	200	385	400
68	-	-	-	-	-	-	-	25 x 30	25 x 30
100	-	-	-	-	-	-	-	25 x 40	25 x 40
150	-	-	-	-	-	-	25 x 30	30 x 40	30 x 40
220	-	-	-	-	-	-	25 x 40	35 x 40	35 x 40
330	-	-	-	-	-	-	30 x 40	35 x 50	35 x 50
	-	-	-	-	-	-	-	40 x 40	40 x 40
470	-	-	-	-	-	-	35 x 40	40 x 50	40 x 50
680	-	-	-	-	-	25 x 30	35 x 50	40 x 70	40 x 70
	-	-	-	-	-	-	40 x 40	-	-
1000	-	-	-	-	-	25 x 40	40 x 50	40 x 100	40 x 100
1500	-	-	-	-	-	30 x 40	40 x 70	-	-
2200	-	-	-	-	25 x 30	35 x 40	40 x 100	-	-

SELECTION CHART FOR C _R , U _R AND RELEVANT NOMINAL CASE SIZES (∅ D x L in mm)									
C _R (μF)	U _R (V)								
	10	16	25	40	63	100	200	385	400
3300	-	-	-	25 x 30	25 x 40	35 x 50	-	-	-
	-	-	-	-	-	40 x 40	-	-	-
4700	-	-	25 x 30	25 x 40	30 x 40	40 x 50	-	-	-
6800	-	25 x 30	25 x 40	30 x 40	35 x 40	40 x 70	-	-	-
10 000	25 x 30	25 x 40	30 x 40	35 x 40	35 x 50	40 x 100	-	-	-
	-	-	-	-	40 x 40	-	-	-	-
15 000	25 x 40	30 x 40	35 x 40	35 x 50	40 x 70	-	-	-	-
	-	-	-	40 x 40	-	-	-	-	-
22 000	30 x 40	35 x 40	35 x 50	40 x 50	40 x 100	-	-	-	-
	-	-	40 x 40	-	-	-	-	-	-
33 000	35 x 40	35 x 50	40 x 50	40 x 70	-	-	-	-	-
	-	40 x 40	-	-	-	-	-	-	-
47 000	35 x 50	40 x 50	40 x 70	40 x 100	-	-	-	-	-
	40 x 40	-	-	-	-	-	-	-	-
68 000	40 x 50	40 x 70	40 x 100	-	-	-	-	-	
100 000	40 x 70	40 x 100	-	-	-	-	-	-	
150 000	40 x 100	-	-	-	-	-	-	-	

DIMENSIONS in millimeters **AND AVAILABLE FORMS**

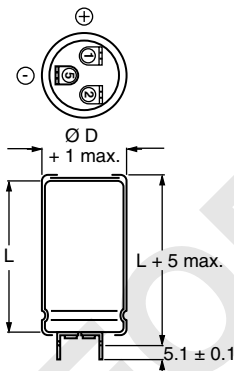

1 = Positive terminal
5 = Negative terminal
Case ∅ D = 25 mm

Fig.1 Printed wiring pin version

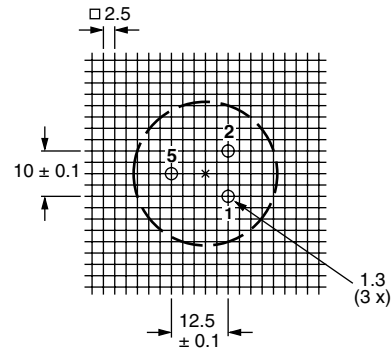

Case ∅ D = 25 mm

Fig.2 Mounting hole pattern viewed from the component side

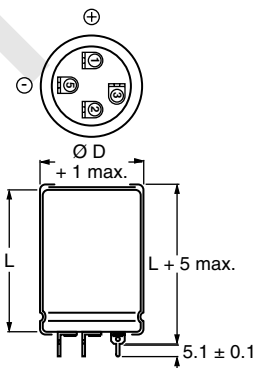

1 = Positive terminal
5 = Negative terminal
Case ∅ D = 30 mm and 35 mm

Fig.3 Printed wiring pin version

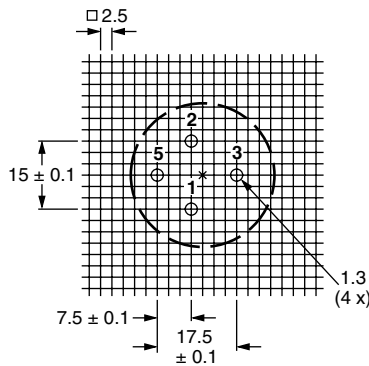

Case ∅ D = 30 mm and 35 mm

Fig.4 Mounting hole pattern viewed from the component side

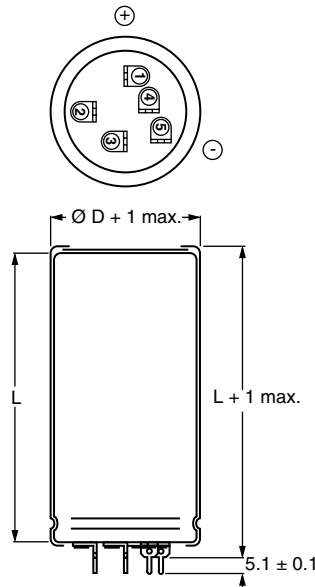
DIMENSIONS in millimeters **AND AVAILABLE FORMS** continued

1 = Positive terminal
 5 = Negative terminal
 Case Ø D = 40 mm

Fig.5 Printed wiring pin version

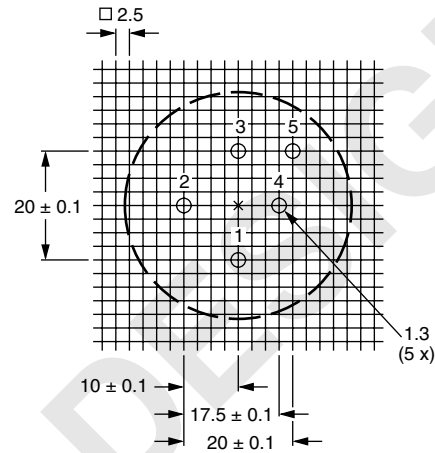

1 = Positive terminal
 5 = Negative terminal
 Case Ø D = 40 mm

Fig.6 Mounting hole pattern viewed from the component side

DIMENSIONS in millimeters, MASS AND PACKAGING QUANTITIES					
NOMINAL CASE SIZE Ø D x L	Ø D _{max.}	L _{max.}	MASS (g)	PACKAGING QUANTITIES (units per box)	CARDBOARD BOX DIMENSIONS L x W x H
25 x 30	26	35	≈ 24	100	290 x 280 x 50
25 x 40	26	45	≈ 28	100	290 x 280 x 60
30 x 40	31	45	≈ 38	100	340 x 330 x 60
35 x 40	36	45	≈ 51	50	390 x 198 x 60
35 x 50	36	55	≈ 66	50	390 x 198 x 70
40 x 40	41	45	≈ 78	50	440 x 223 x 60
40 x 50	41	55	≈ 82	50	440 x 223 x 70
40 x 70	41	75	≈ 110	25	230 x 230 x 90
40 x 100	41	105	≈ 176	25	230 x 230 x 120

MOUNTING

When a number of capacitors are connected in a bank, they must not be closer together than 15 mm, when no derating of ripple current and/or temperature is applied.

Pin numbers 2, 3 and 4 (if present) must be free from the electrical circuit.

ELECTRICAL DATA	
SYMBOL	DESCRIPTION
C _R	rated capacitance at 100 Hz
I _R	rated RMS ripple current at 100 Hz, 85 °C or at 20 kHz, 70 °C
I _{L1}	max. leakage current after 1 minute at U _R
I _{L5}	max. leakage current after 5 minutes at U _R
ESR	max. equivalent series resistance at 100 Hz
Z	max. impedance at 10 kHz

Note

(1) Unless otherwise specified, all electrical values apply at
 T_a = 20 °C, P = 86 kPa to 106 kPa, RH = 45 % to 75 %

ORDERING EXAMPLE

10 000 µF/25 V; ± 20 %

Nominal case size: Ø 30 x 40 mm

Ordering code: MALPEYD00BB510E02W

ELECTRICAL DATA AND ORDERING INFORMATION									
U_R (V)	C_R 100 Hz (μ F)	NOMINAL CASE SIZE \varnothing D x L (mm)	I_R 100 Hz 85 °C (A)	I_R 20 kHz 70 °C (A)	I_{L1} 1 min (mA)	I_{L5} 5 min (mA)	ESR 100 Hz (m Ω)	Z 10 kHz (m Ω)	ORDERING CODE
10	10 000	25 x 30	3.1	5.9	0.60	0.20	51	40	MALPEYD00AV510C02W
	15 000	25 x 40	4.1	7.8	0.90	0.30	37	30	MALPEYD00AB515C02W
	22 000	30 x 40	5.0	9.5	1.32	0.44	30	25	MALPEYD00BB522C02W
	33 000	35 x 40	5.5	10.4	1.98	0.66	28	24	MALPEYD00CB533C02W
	47 000	35 x 50	6.8	12.9	2.82	0.94	23	20	MALPEYD00CD547C02W
	47 000	40 x 40	5.8	10.4	2.82	0.94	29	22	MALPEYD00DB547C02W
	68 000	40 x 50	7.1	13.5	4.08	1.36	24	20	MALPEYD00DD568C02W
	100 000	40 x 70	9.2	17.4	6.00	2.00	19	16	MALPEYD00DG610C02W
150 000	40 x 100	12.0	22.7	9.00	3.00	16	14	MALPEYD00DM615C02W	
16	6800	25 x 30	3.1	5.9	0.65	0.22	53	42	MALPEYD00AV468D02W
	10 000	25 x 40	4.0	7.6	0.96	0.32	39	34	MALPEYD00AB510D02W
	15 000	30 x 40	5.0	9.5	1.44	0.48	31	27	MALPEYD00BB515D02W
	22 000	35 x 40	5.5	10.4	2.12	0.71	29	26	MALPEYD00CB522D02W
	33 000	35 x 50	6.7	12.7	3.17	1.06	23	21	MALPEYD00CD533D02W
	33 000	40 x 40	5.7	10.8	3.17	1.06	30	24	MALPEYD00DB533D02W
	47 000	40 x 50	7.0	13.3	4.52	1.51	24	20	MALPEYD00DD547D02W
	68 000	40 x 70	9.2	17.4	6.53	2.18	19	16	MALPEYD00DG568D02W
100 000	40 x 100	12.0	22.7	9.60	3.20	16	14	MALPEYD00DM610D02W	
25	4700	25 x 30	2.9	5.5	0.71	0.24	60	42	MALPEYD00AV447E02W
	6800	25 x 40	3.9	7.4	1.02	0.34	42	34	MALPEYD00AB468E02W
	10 000	30 x 40	4.8	9.1	1.50	0.50	34	27	MALPEYD00BB510E02W
	15 000	35 x 40	5.3	10.0	2.25	0.75	30	26	MALPEYD00CB515E02W
	22 000	35 x 50	6.5	12.3	3.30	1.10	24	21	MALPEYD00CD522E02W
	22 000	40 x 40	5.7	10.8	3.30	1.10	31	24	MALPEYD00DB522E02W
	33 000	40 x 50	7.0	13.3	4.95	1.65	25	20	MALPEYD00DD533E02W
	47 000	40 x 70	9.2	17.4	7.05	2.35	19	16	MALPEYD00DG547E02W
68 000	40 x 100	12.0	22.7	10.20	3.40	16	14	MALPEYD00DM568E02W	
40	3300	25 x 30	2.9	5.5	0.80	0.27	87	63	MALPEYD00AV433G02W
	4700	25 x 40	3.8	7.2	1.13	0.38	62	47	MALPEYD00AB447G02W
	6800	30 x 40	4.7	8.9	1.64	0.55	49	38	MALPEYD00BB468G02W
	10 000	35 x 40	5.2	9.8	2.40	0.80	48	37	MALPEYD00CB510G02W
	15 000	35 x 50	6.3	11.9	3.60	1.20	37	28	MALPEYD00CD515G02W
	15 000	40 x 40	5.6	10.6	3.60	1.20	50	35	MALPEYD00DB515G02W
	22 000	40 x 50	5.8	11.0	5.28	1.76	39	28	MALPEYD00DD522G02W
	33 000	40 x 70	7.8	14.8	7.92	2.64	28	21	MALPEYD00DG533G02W
47 000	40 x 100	10.4	19.7	11.28	3.76	22	17	MALPEYD00DM547G02W	
63	2200	25 x 30	2.5	4.7	0.84	0.28	83	62	MALPEYD00AV422J02W
	3300	25 x 40	3.3	6.2	1.25	0.42	58	42	MALPEYD00AB433J02W
	4700	30 x 40	4.1	7.8	1.78	0.60	49	38	MALPEYD00BB447J02W
	6800	35 x 40	4.5	8.5	2.57	0.86	48	37	MALPEYD00CB468J02W
	10 000	35 x 50	5.4	10.2	3.78	1.26	37	28	MALPEYD00CD510J02W
	10 000	40 x 40	4.6	8.7	3.78	1.26	52	37	MALPEYD00DB510J02W
	15 000	40 x 70	7.5	14.2	5.67	1.89	29	24	MALPEYD00DG515J02W
22 000	40 x 100	10.0	19.0	8.32	2.77	22	19	MALPEYD00DM522J02W	
100	680	25 x 30	1.74	3.30	0.41	0.14	190	130	MALPEYD00AV368L02W
	1000	25 x 40	2.34	4.44	0.60	0.20	130	90	MALPEYD00AB410L02W
	1500	30 x 40	2.95	5.59	0.90	0.30	95	67	MALPEYD00BB415L02W
	2200	35 x 40	3.69	7.00	1.32	0.44	71	53	MALPEYD00CB422L02W
	3300	35 x 50	4.37	8.29	1.98	0.66	55	41	MALPEYD00CD433L02W
	3300	40 x 40	4.16	7.89	1.98	0.66	64	48	MALPEYD00DB433L02W
	4700	40 x 50	5.21	9.88	2.82	0.94	49	38	MALPEYD00DD447L02W
	6800	40 x 70	6.97	13.22	4.08	1.36	35	28	MALPEYD00DG468L02W
10 000	40 x 100	9.50	18.00	6.00	2.00	26	21	MALPEYD00DM510L02W	

ELECTRICAL DATA AND ORDERING INFORMATION									
U_R (V)	C_R 100 Hz (μ F)	NOMINAL CASE SIZE \varnothing D x L (mm)	I_R 100 Hz 85 °C (A)	I_R 20 kHz 70 °C (A)	I_{L1} 1 min (mA)	I_{L5} 5 min (mA)	ESR 100 Hz (m Ω)	Z 10 kHz (m Ω)	ORDERING CODE
200	150	25 x 30	0.70	1.33	0.18	0.06	1000	770	MALPEYD00AV315S02W
	220	25 x 40	0.94	1.78	0.26	0.09	680	525	MALPEYD00AB322S02W
	330	30 x 40	1.27	2.41	0.40	0.14	460	360	MALPEYD00BB333S02W
	470	35 x 40	1.66	3.15	0.57	0.19	320	250	MALPEYD00CB347S02W
	680	35 x 50	2.19	4.15	0.82	0.28	220	170	MALPEYD00CD368S02W
	680	40 x 40	2.17	4.11	0.82	0.28	220	170	MALPEYD00DB368S02W
	1000	40 x 50	2.86	5.42	1.20	0.40	150	115	MALPEYD00DD410S02W
	1500	40 x 70	3.81	7.22	1.80	0.60	110	85	MALPEYD00DG415S02W
	2200	40 x 100	5.20	9.86	2.64	0.88	80	60	MALPEYD00DM422S02W
385	68	25 x 30	0.47	0.89	0.16	0.06	2200	1480	MALPEYD00AV268R02W
	100	25 x 40	0.64	1.21	0.23	0.08	1500	1020	MALPEYD00AB310R02W
	150	30 x 40	0.90	1.71	0.35	0.12	1000	700	MALPEYD00BB315R02W
	220	35 x 40	1.15	2.18	0.51	0.17	680	480	MALPEYD00CB322R02W
	330	35 x 50	1.53	2.90	0.77	0.26	450	340	MALPEYD00CD333R02W
	330	40 x 40	1.52	2.88	0.77	0.26	450	340	MALPEYD00DB333R02W
	470	40 x 50	1.96	3.72	1.09	0.36	320	260	MALPEYD00DD347R02W
	680	40 x 70	2.70	5.12	1.58	0.53	220	190	MALPEYD00DG368R02W
	1000	40 x 100	3.70	7.02	2.31	0.78	180	140	MALPEYD00DM410R02W
400	68	25 x 30	0.54	1.02	0.16	0.06	2100	1000	MALPEYD00AV268X02W
	100	25 x 40	0.73	1.38	0.24	0.08	1400	780	MALPEYD00AB310X02W
	150	30 x 40	0.98	1.86	0.36	0.12	950	520	MALPEYD00BB315X02W
	220	35 x 40	1.28	2.43	0.52	0.17	650	400	MALPEYD00CB322X02W
	330	35 x 50	1.67	3.17	0.79	0.26	480	280	MALPEYD00CD333X02W
	330	40 x 40	1.67	3.17	0.79	0.26	480	280	MALPEYD00DB333X02W
	470	40 x 50	2.12	4.02	1.12	0.37	340	220	MALPEYD00DD347X02W
	680	40 x 70	2.90	5.50	1.63	0.54	235	155	MALPEYD00DG368X02W
	1000	40 x 100	4.05	7.68	2.40	0.80	160	110	MALPEYD00DM410X02W

ADDITIONAL ELECTRICAL DATA		
PARAMETER	CONDITIONS	VALUE
Voltage		
Surge voltage	≤ 250 V versions	$U_s = 1.15 \times U_R$
	≥ 385 V versions	$U_s = 1.1 \times U_R$
Reverse voltage		$U_{rev} \leq 1$ V
Current		
Leakage current	After 1 minute at U_R	$I_{L1} \leq 0.006 C_R \times U_R + 4 \mu$ A
	After 5 minutes at U_R	$I_{L5} \leq 0.002 C_R \times U_R + 4 \mu$ A
Inductance		
Equivalent series inductance (ESL)	Case \varnothing D = 25 mm	max. 25 nH
	Case \varnothing D = 30 mm and 35 mm	max. 30 nH
	Case \varnothing D = 40 mm	max. 35 nH

LIFETIME TABLE rated voltage: ≤ 100 V

INTERRELATION BETWEEN ALTERNATING CURRENT, AMBIENT TEMPERATURE AND LIFETIME																	
I/I_R (frequency dependent)						SURFACE TEMPERATURE RISE ΔT_0 (°C)	LIFETIME MULTIPLIER (depending on I/I_R and T_a)										
FREQUENCY (Hz)							AMBIENT TEMPERATURE T_a (°C)										
50	100	250	500	1000	> 2500		40	45	50	55	60	65	70	75	80	85	
0.19	0.20	0.21	0.22	0.23	0.24	0.2	63	40	26	17	11	7.4	5.0	3.4	2.4	1.64	
0.39	0.40	0.42	0.44	0.46	0.47	0.6	57	36	23	15	10	6.8	4.6	3.2	2.2	1.53	
0.58	0.60	0.62	0.66	0.69	0.71	1.3	48	31	20	13	8.9	6.0	4.1	2.8	2.0	1.38	
0.78	0.80	0.83	0.88	0.92	0.95	2.1	39	25	17	11	7.5	5.1	3.5	2.4	1.7	1.21	
0.97	1.00	1.04	1.10	1.15	1.18	3.2	30	20	13	9.0	6.1	4.2	2.9	2.0	1.4	1.00	
1.17	1.20	1.25	1.31	1.38	1.42	4.4	22	15	10	7.0	4.8	3.4	2.3	1.7	1.2		
1.36	1.40	1.46	1.53	1.61	1.66	6.0	16	11	7.7	5.3	3.7	2.6	1.8	1.3			
1.55	1.60	1.67	1.75	1.84	1.89	7.9	11	8.0	5.6	3.9	2.8	2.0	1.4	1.0			
1.75	1.80	1.87	1.97	2.07	2.13	10	7.8	5.5	3.9	2.8	2.0	1.4	1.0				
1.94	2.00	2.08	2.19	2.30	2.37	12	5.3	3.8	2.7	2.0	1.4	1.0					combination not permitted
2.14	2.20	2.29	2.41	2.53	2.60	15	3.5	2.5	1.8	1.3							
2.33	2.40	2.50	2.63	2.76	2.84	17	2.2	1.6	1.2								
2.53	2.60	2.71	2.85	2.99	3.08	20	1.4	1.1									

Notes

- I_R 100 Hz alternating current (A) at upper category temperature T_{UC} taken from datasheet
- I User current (A)
- T_a Ambient temperature of capacitor (°C)
- ΔT_0 Surface temperature rise of capacitor caused by AC load (°C)
- L Lifetime multiplier

LIFETIME TABLE rated voltage: > 100 V

INTERRELATION BETWEEN ALTERNATING CURRENT, AMBIENT TEMPERATURE AND LIFETIME																	
I/I_R (frequency dependent)						SURFACE TEMPERATURE RISE ΔT_0 (°C)	LIFETIME MULTIPLIER (depending on I/I_R and T_a)										
FREQUENCY (Hz)							AMBIENT TEMPERATURE T_a (°C)										
50	100	250	500	1000	> 2500		40	45	50	55	60	65	70	75	80	85	
0.16	0.20	0.25	0.27	0.28	0.29	0.2	94	60	38	25	17	11	7.5	5.1	2.4	1.64	
0.32	0.40	0.49	0.54	0.57	0.59	0.6	83	53	35	23	15	10	6.9	3.2	2.2	1.54	
0.48	0.60	0.74	0.81	0.85	0.88	1.2	68	45	30	20	13	9.0	6.2	2.8	2.0	1.39	
0.64	0.80	0.98	1.07	1.13	1.18	2.0	54	36	24	16	11	7.6	5.3	2.5	1.7	1.22	
0.80	1.00	1.23	1.34	1.42	1.47	3.1	41	28	19	13	9.0	6.3	2.9	2.1	1.5	1.00	
0.96	1.20	1.47	1.61	1.70	1.76	4.9	30	21	15	10	7.1	5	2.4	1.7	1.2		
1.12	1.40	1.72	1.88	1.98	2.06	6.7	21	15	11	7.7	5.5	2.6	1.9	1.3			
1.28	1.60	1.96	2.15	2.27	2.35	8.6	15	11	7.9	5.7	2.7	2.0	1.4	1.0			
1.44	1.80	2.21	2.42	2.55	2.65	11	10	7.6	5.6	2.7	2.0	1.5	1.1				
1.60	2.00	2.45	2.69	2.83	2.94	13	7.0	5.3	2.6	2.0	1.5	1.1					combination not permitted
1.76	2.20	2.70	2.95	3.12	3.23	15	3.2	2.4	1.8	1.4	1.0						
1.92	2.40	2.94	3.22	3.40	3.53	18	2.1	1.6	1.2								
2.08	2.60	3.19	3.49	3.68	3.82	20	1.4	1.1									

Notes

- I_R 100 Hz alternating current (A) at upper category temperature T_{UC} taken from datasheet
- I User current (A)
- T_a Ambient temperature of capacitor (°C)
- ΔT_0 Surface temperature rise of capacitor caused by AC load (°C)
- L Lifetime multiplier



Disclaimer

All product specifications and data are subject to change without notice.

Vishay Intertechnology, Inc., its affiliates, agents, and employees, and all persons acting on its or their behalf (collectively, "Vishay"), disclaim any and all liability for any errors, inaccuracies or incompleteness contained herein or in any other disclosure relating to any product.

Vishay disclaims any and all liability arising out of the use or application of any product described herein or of any information provided herein to the maximum extent permitted by law. The product specifications do not expand or otherwise modify Vishay's terms and conditions of purchase, including but not limited to the warranty expressed therein, which apply to these products.

No license, express or implied, by estoppel or otherwise, to any intellectual property rights is granted by this document or by any conduct of Vishay.

The products shown herein are not designed for use in medical, life-saving, or life-sustaining applications unless otherwise expressly indicated. Customers using or selling Vishay products not expressly indicated for use in such applications do so entirely at their own risk and agree to fully indemnify Vishay for any damages arising or resulting from such use or sale. Please contact authorized Vishay personnel to obtain written terms and conditions regarding products designed for such applications.

Product names and markings noted herein may be trademarks of their respective owners.