

# Specify AEL

## ZTT Series With Built-In Capacitor

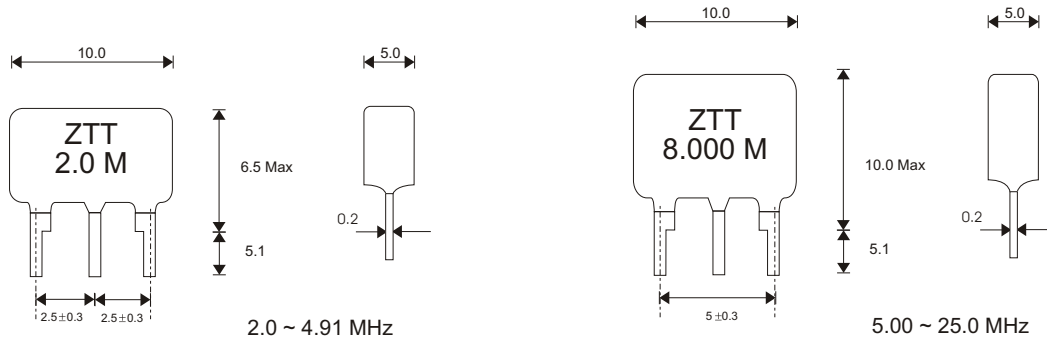

Ceramic Resonators



2.0 ~ 4.91 MHz

5.00 ~ 25.0 MHz

### FEATURES

- Low Cost
- Ex-Stock Availability
- Industry Standard Dimensions
- Good Stability

### APPLICATIONS

- Microprocessor Systems
- Datacommunications
- Consumer Electronics
- Automotive Electronics

### STANDARD SPECIFICATION

Part Number	ZTT □.□□ MG	ZTT □.□□ MG	ZTT □.□□ MG	ZTT □.□□ MG	ZTT □.□□ MT	ZTT □.□□ MX
Frequency Range	2.00 ~ 2.99	3.00 ~ 3.49	3.50 ~ 4.99	5.00 ~ 6.99	7.00 ~ 13.00	13.01 ~ 25.00
Frequency Accuracy At 25°C	+/-0.5	+/-0.5	+/-0.5	+/-0.5	+/-0.5	+/-0.5
Temp. Stability -20°C to +80°C	+/-0.3	+/-0.3	+/-0.3	+/-0.3	+/-0.3	+/-0.3
Ageing (Over 10 years)	+/-0.3	+/-0.3	+/-0.3	+/-0.3	+/-0.3	+/-0.3
ESR (Ohms Max)	80	50	30	30	25	55
Max. Voltage	100V DC	100V DC	100V DC	100V DC	100V DC	100V DC
Insulation Resistance (Ohms)	$5 \times 10^{-8}$ Ohms (+10V DC)	$5 \times 10^{-8}$ Ohms (+10V DC)	$5 \times 10^{-8}$ Ohms (+10V DC)	$5 \times 10^{-8}$ Ohms (+10V DC)	$5 \times 10^{-8}$ Ohms (+10V DC)	$5 \times 10^{-8}$ Ohms (+10V DC)

### TEST CIRCUITS

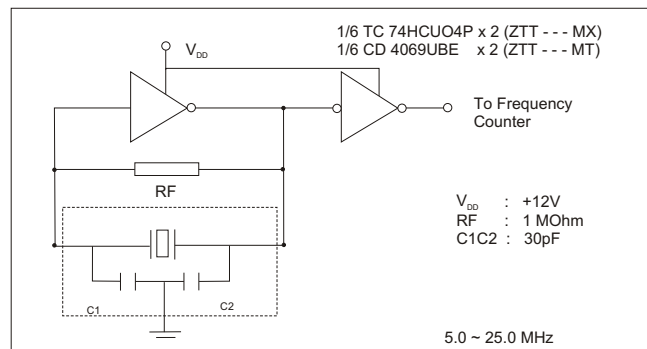
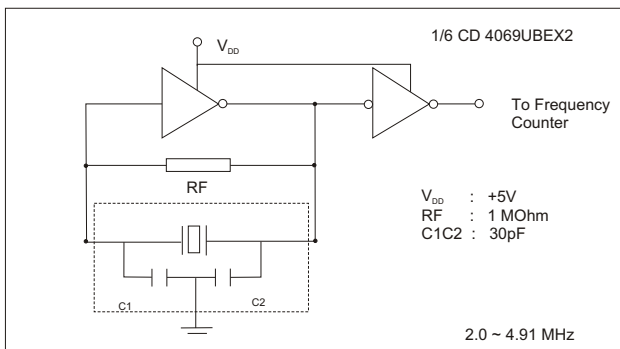

[www.aelcrystals.co.uk](http://www.aelcrystals.co.uk) quartz based frequency control components

Order Hotline +44 1293 524245

[www.aelcrystals.co.uk](http://www.aelcrystals.co.uk)  
[sales@aelcrystals.co.uk](mailto:sales@aelcrystals.co.uk)