

HD74LS93

4-bit Binary Counter

REJ03D0423-0200

Rev.2.00

Feb.18.2005

The HD74LS93 contains four master-slave flip-flops and additional gating to provide a divide-by-two counter and three-state binary counter for divide-by-eight. To use this maximum count length of this counter, the B input is connected to the Q_A output. The input count pulses are applied to input A and the outputs are described in the appropriate function table.

Features

- Ordering Information

Part Name	Package Type	Package Code (Previous Code)	Package Abbreviation	Taping Abbreviation (Quantity)
HD74LS93P	DILP-14 pin	PRDP0014AB-B (DP-14AV)	P	—
HD74LS93FPEL	SOP-14 pin (JEITA)	PRSP0014DF-B (FP-14DAV)	FP	EL (2,000 pcs/reel)

Note: Please consult the sales office for the above package availability.

Pin Arrangement

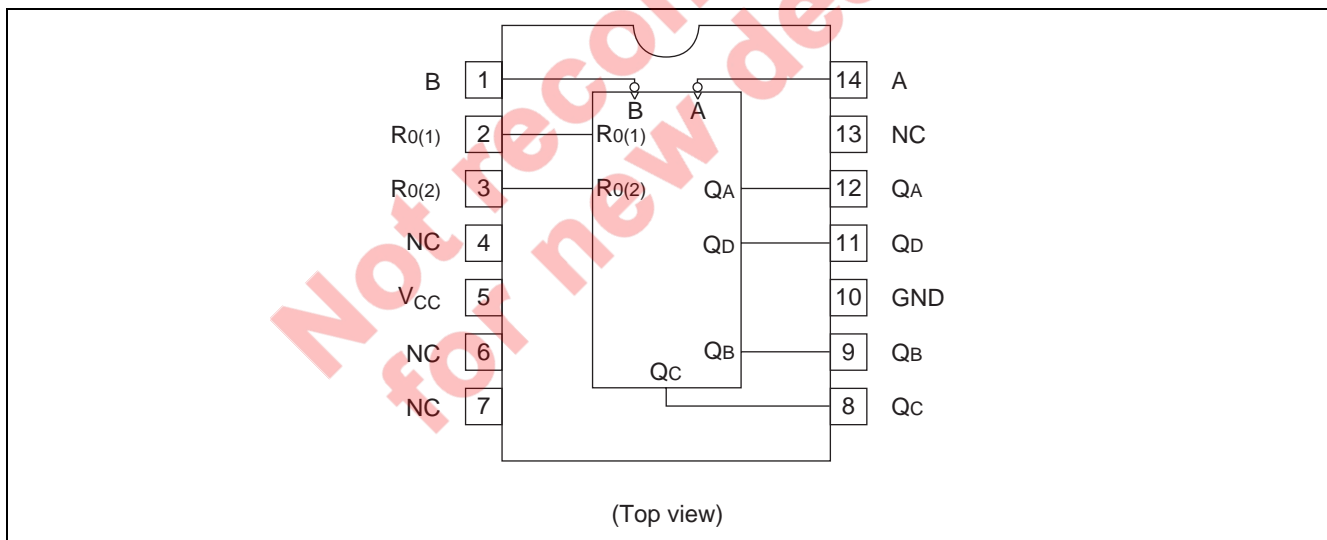

Function Table

• Reset / Count Function Table

Reset inputs		Outputs			
R ₀₍₁₎	R ₀₍₂₎	Q _D	Q _C	Q _B	Q _A
H	H	L	L	L	L
L	X	Count			
X	L	Count			

Note: H; high level, L; low level, X; irrelevant

• BCD Count Sequence (Notes 1)

Count	Outputs			
	Q _D	Q _C	Q _B	Q _A
0	L	L	L	L
1	L	L	L	H
2	L	L	H	L
3	L	L	H	H
4	L	H	L	H
5	L	H	L	H
6	L	H	H	L
7	L	H	H	H
8	H	L	L	L
9	H	L	L	H
10	H	L	H	L
11	H	L	H	H
12	H	H	L	L
13	H	H	L	H
14	H	H	H	L
15	H	H	H	H

Notes: 1. Output QA is connected to input B for BCD count.
2. H; high level, L; low level

Block Diagram

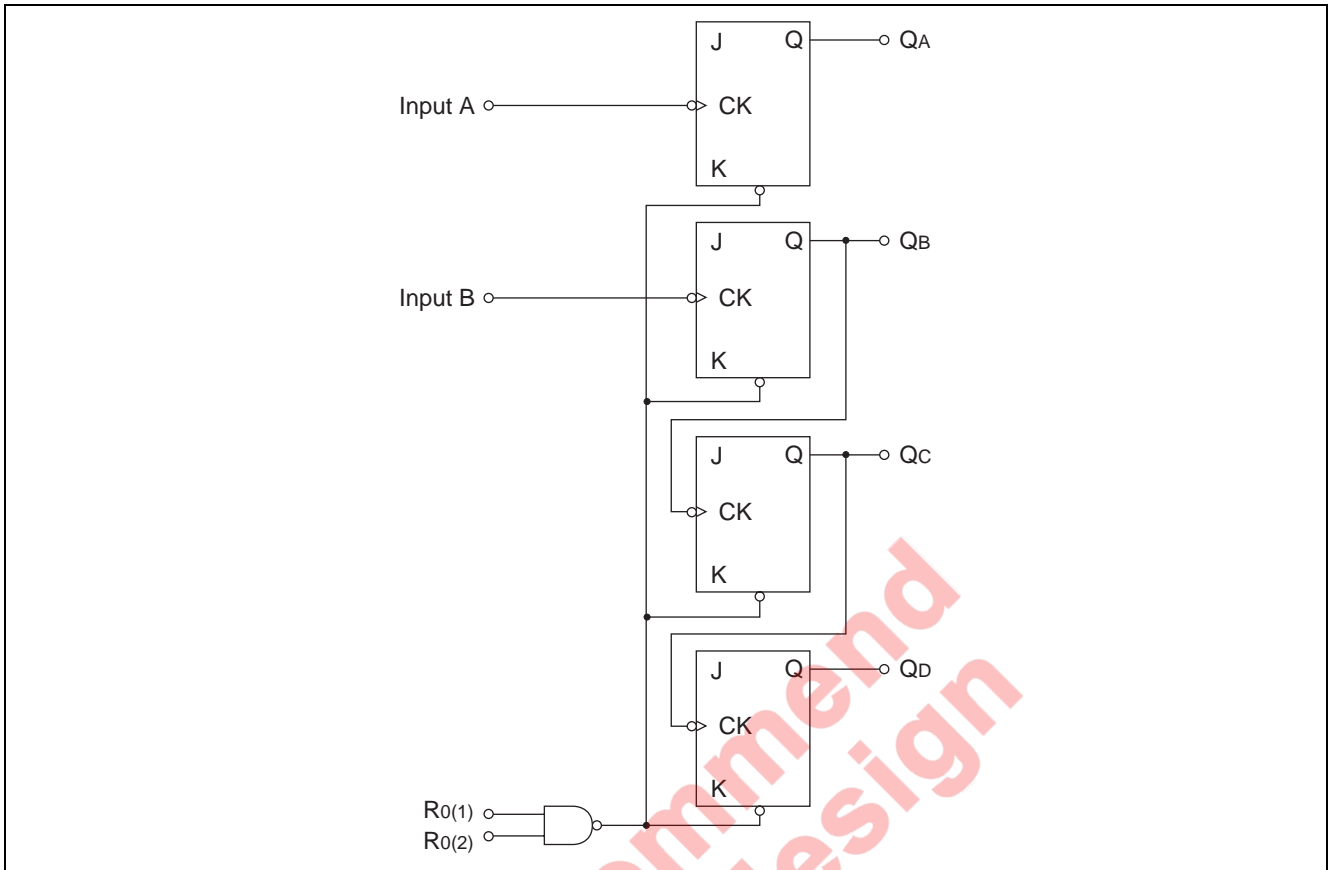

Absolute Maximum Ratings

Item	Symbol	Ratings	Unit
Supply voltage	V_{CC}	7	V
Input voltage	R Inputs	V_{IN}	7
	A, B Inputs	V_{IN}	5.5
Power dissipation	P_T	400	mW
Storage temperature	T_{stg}	-65 to +150	°C

Note: Voltage value, unless otherwise noted, are with respect to network ground terminal.

Recommended Operating Conditions

Item	Symbol	Min	Typ	Max	Unit	
Supply voltage	V_{CC}	4.75	5.00	5.25	V	
Output current	I_{OH}	—	—	-400	μA	
	I_{OL}	—	—	8	mA	
Operating temperature	T_{opr}	-20	25	75	°C	
Count frequency	A input	f_{count}	0	—	32	MHz
	B input		0	—	16	
Pulse width	A input	t_w	15	—	—	ns
	B input		30	—	—	
	Reset input		15	—	—	
Setup time	t_{su}	25	—	—	ns	

Electrical Characteristics

(Ta = -20 to +75 °C)

Item	Symbol	min.	typ.*	max.	Unit	Condition	
Input voltage	V _{IH}	2.0	—	—	V		
	V _{IL}	—	—	0.8	V		
Output voltage	V _{OH}	2.7	—	—	V	V _{CC} = 4.75 V, V _{IH} = 2 V, V _{IL} = 0.8 V, I _{OH} = -400 μA	
	V _{OL}	—	—	0.4	V	V _{CC} = 4.75 V, V _{IH} = 2 V, V _{IL} = 0.8 V	
—		—	0.5				
Input current	Any reset	I _{IL}	—	—	-0.4	mA	V _{CC} = 5.25 V, V _I = 0.4 V
	A input		—	—	-2.4		
	B input		—	—	-1.6		
	Any reset	I _{IH}	—	—	20	μA	V _{CC} = 5.25 V, V _I = 2.7 V
	A input		—	—	40		
	B input		—	—	40		
	Any reset	I _I	—	—	0.1	mA	V _{CC} = 5.25 V
A input	—		—	0.2			
B input	—		—	0.2			
Short-circuit output current	I _{OS}	-20	—	-100	mA	V _{CC} = 5.25 V	
Supply current	I _{CC} ***	—	9	15	mA	V _{CC} = 5.25 V	
Input clamp voltage	V _{IK}	—	—	-1.5	V	V _{CC} = 4.75 V, I _{IN} = -18 mA	

Notes: * V_{CC} = 5 V, Ta = 25°C

** Q_A output is tested at specified I_{OL} plus the limit value of I_{IL} for the B input. This permits driving the B input while maintaining full fan-out capability.

*** I_{CC} is measured with all outputs open, both R₀ inputs grounded following momentary connection to 4.5 V, and all other inputs grounded.

Switching Characteristics

(V_{CC} = 5 V, Ta = 25°C)

Item	Symbol	Inputs	Outputs	min.	typ.	max.	Unit	Condition
Maximum count frequency	f _{max}	A	Q _A	32	42	—	MHz	C _L = 15 pF, R _L = 2 kΩ
		B	Q _B	16	—	—		
Propagation delay time	t _{PLH}	A	Q _A	—	10	16	ns	
	t _{PHL}			—	12	18		
	t _{PLH}	A	Q _D	—	46	70		
	t _{PHL}			—	46	70		
	t _{PLH}	B	Q _B	—	10	16		
	t _{PHL}			—	14	21		
	t _{PLH}	B	Q _C	—	21	32		
	t _{PHL}			—	23	35		
	t _{PLH}	B	Q _D	—	34	51		
	t _{PHL}			—	34	51		
t _{PHL}	Set-to-0	Q _A to Q _D	—	26	40			

Note: Refer to Test Circuit and Waveform of the Common Item "TTL Common Matter (Document No.: REJ27D0005-0100)".

Timing Definition

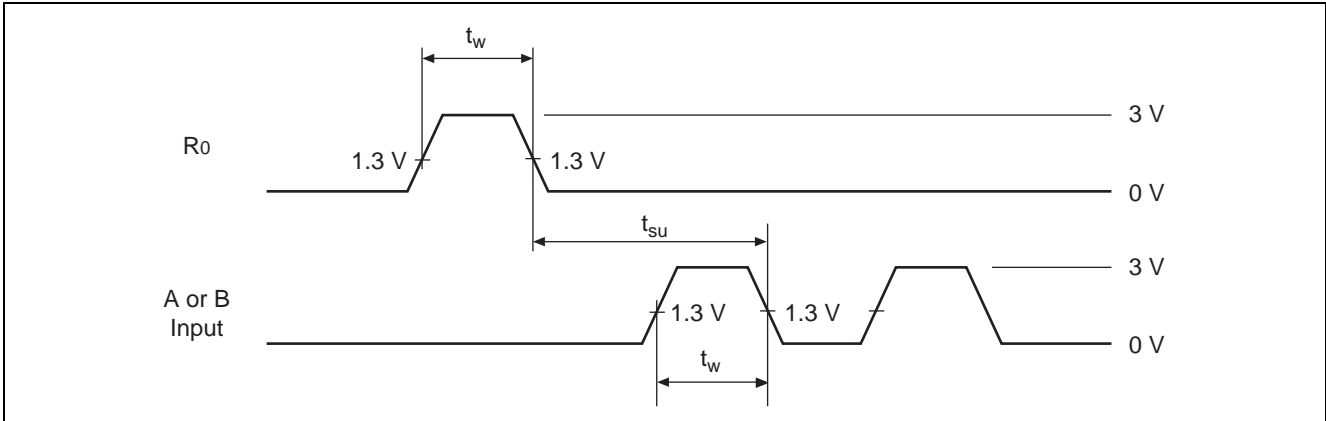

Testing Method

Test Circuit

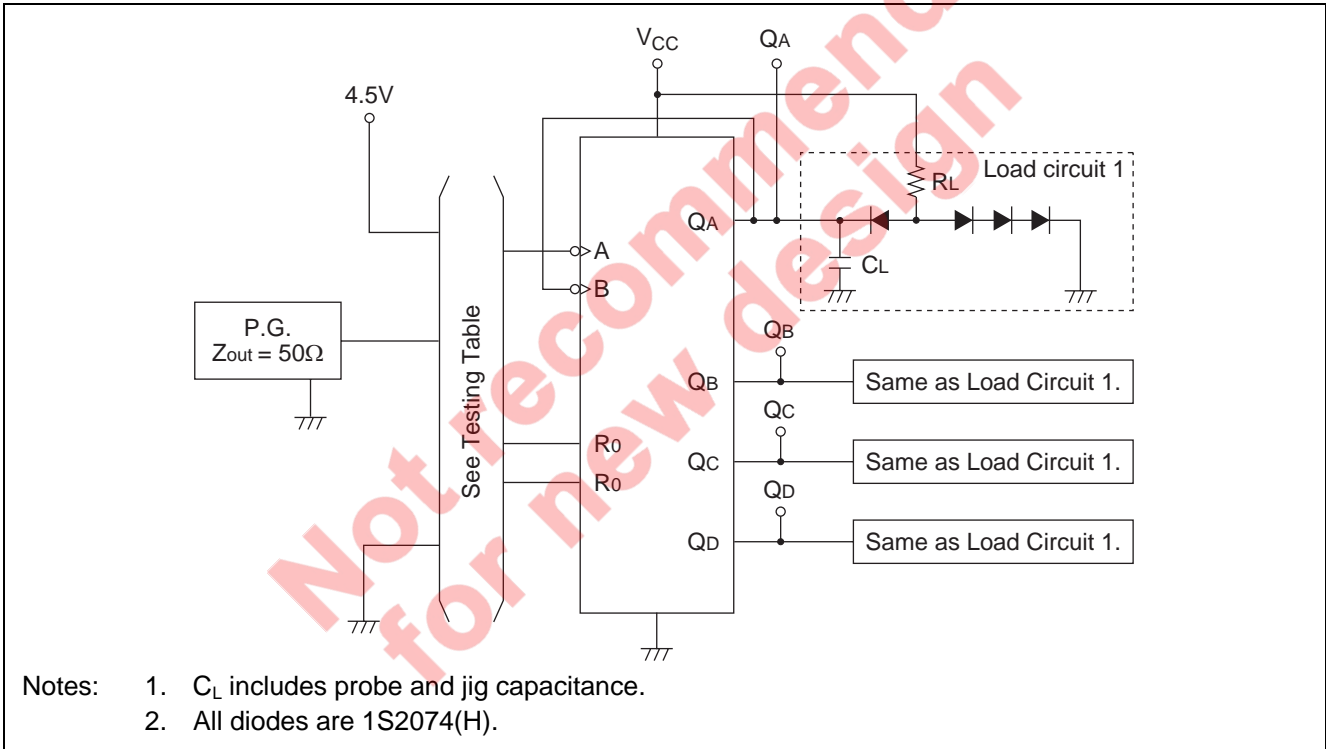

Testing Table

Item	From input to output	Inputs			Outputs			
		A	B	R ₀	Q _A	Q _B	Q _C	Q _D
f _{max}	A → Q	IN	to Q _A	GND	Out	Out	Out	Out
	B → Q	4.5 V	IN	GND	—	Out	Out	Out
t _{PLH} t _{PHL}	A → Q _A	IN	to Q _A	GND	Out	—	—	—
	A → Q _D	IN	to Q _A	GND	—	—	—	Out
	B → Q _B	4.5 V	IN	GND	—	Out	—	—
	B → Q _C	4.5 V	IN	GND	—	—	Out	—
	B → Q _D	4.5 V	IN	GND	—	—	—	Out
	R ₀ ** → Q	IN*	to Q _A	IN	Out	Out	Out	Out

* For initialized.

** Measured with each input and unused inputs at 4.5 V.

Waveform

1. f_{max}, t_{PLH}, t_{PHL} (Clock → Q)

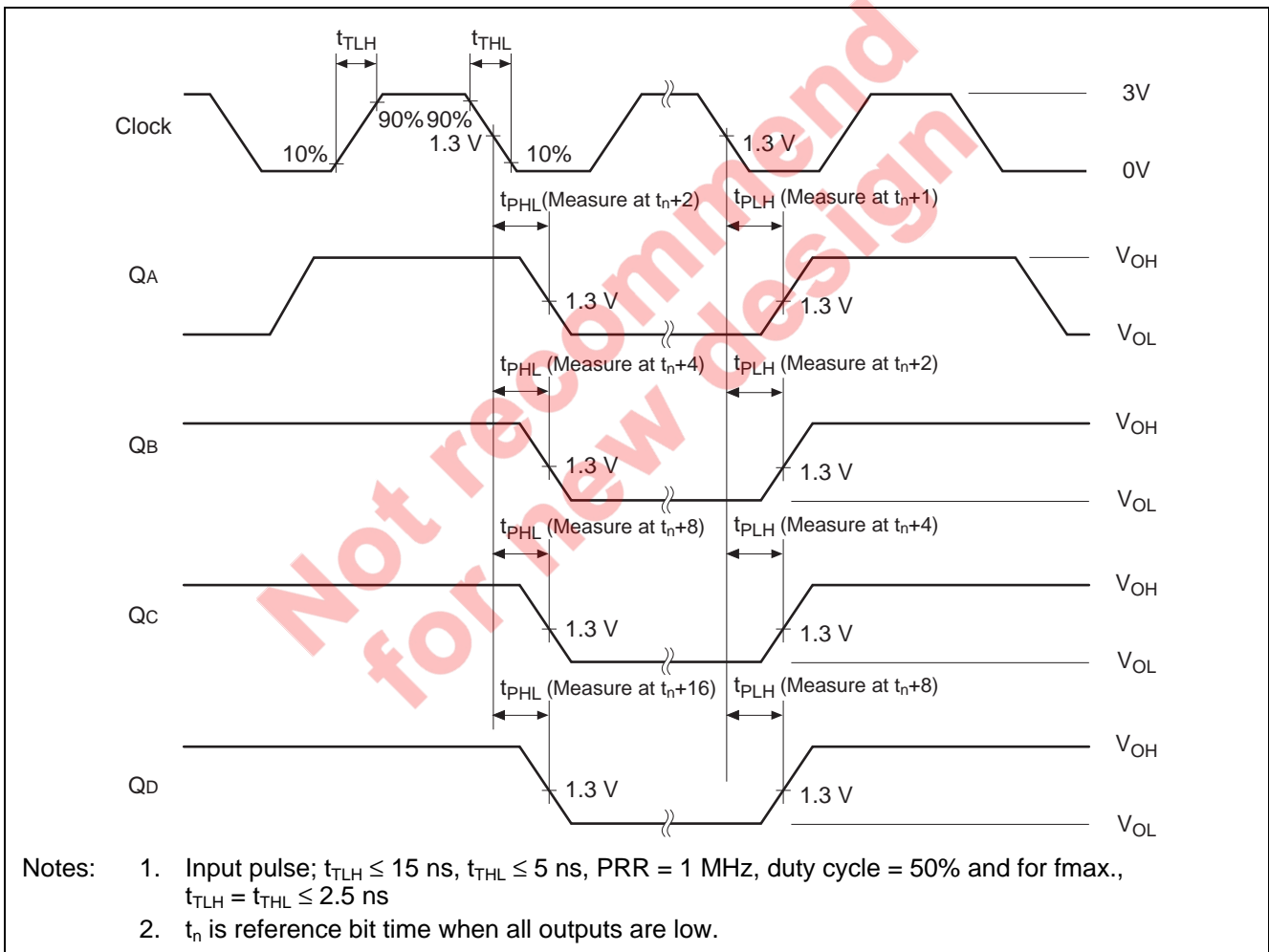

2. t_{PHL} ($R_0 \rightarrow Q$)

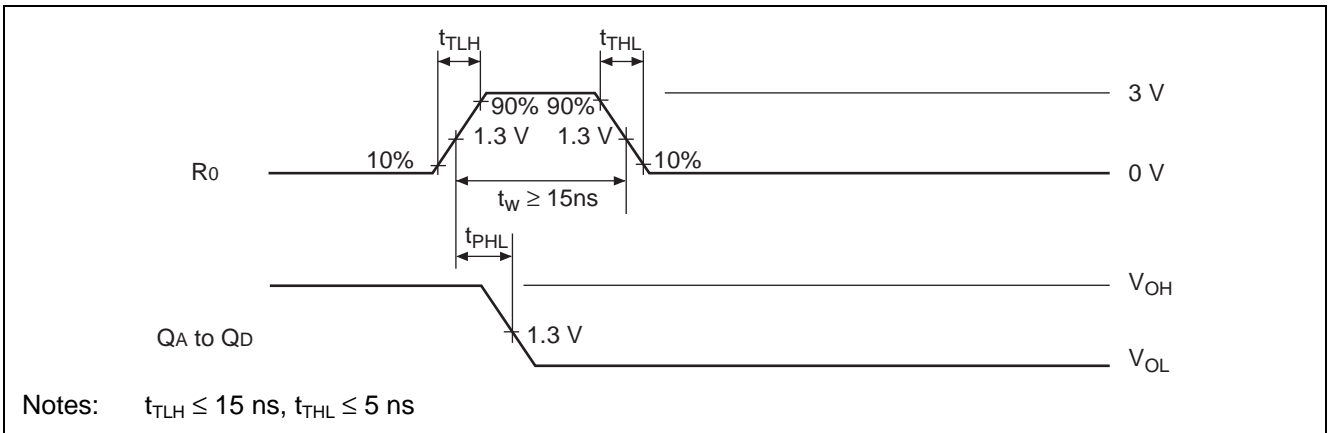

Not recommend
for new design

Package Dimensions

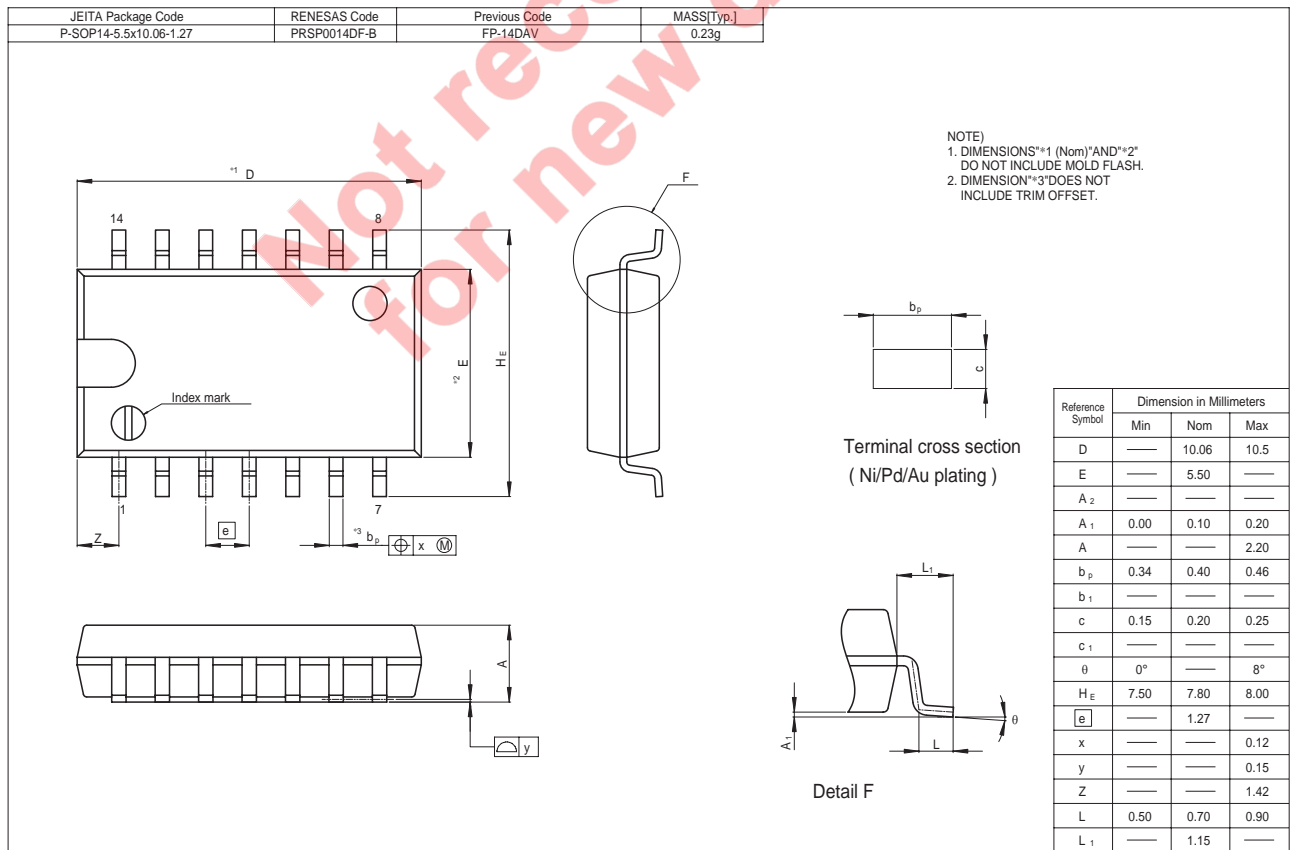
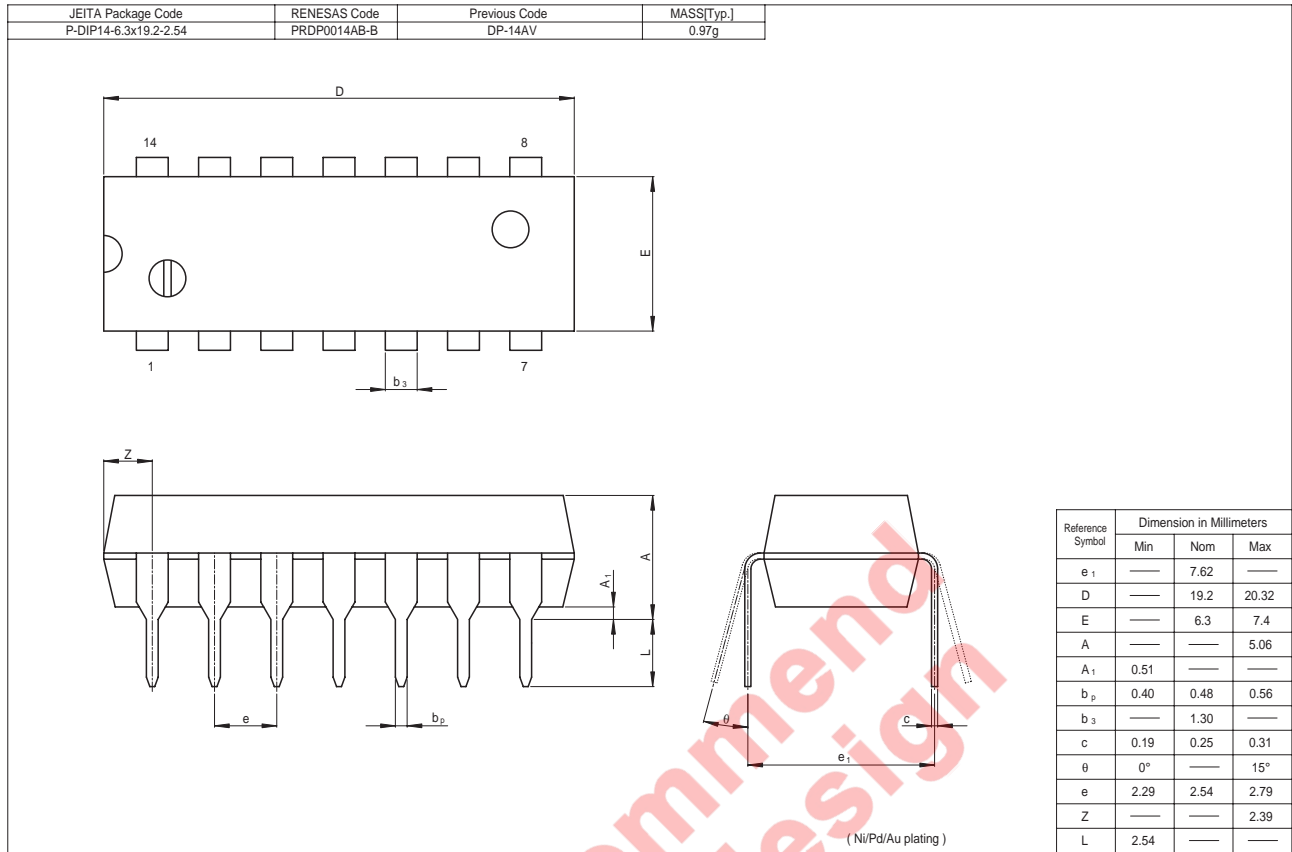

Renesas Technology Corp. Sales Strategic Planning Div. Nippon Bldg., 2-6-2, Ohte-machi, Chiyoda-ku, Tokyo 100-0004, Japan

Keep safety first in your circuit designs!

1. Renesas Technology Corp. puts the maximum effort into making semiconductor products better and more reliable, but there is always the possibility that trouble may occur with them. Trouble with semiconductors may lead to personal injury, fire or property damage.
Remember to give due consideration to safety when making your circuit designs, with appropriate measures such as (i) placement of substitutive, auxiliary circuits, (ii) use of nonflammable material or (iii) prevention against any malfunction or mishap.

Notes regarding these materials

1. These materials are intended as a reference to assist our customers in the selection of the Renesas Technology Corp. product best suited to the customer's application; they do not convey any license under any intellectual property rights, or any other rights, belonging to Renesas Technology Corp. or a third party.
 2. Renesas Technology Corp. assumes no responsibility for any damage, or infringement of any third-party's rights, originating in the use of any product data, diagrams, charts, programs, algorithms, or circuit application examples contained in these materials.
 3. All information contained in these materials, including product data, diagrams, charts, programs and algorithms represents information on products at the time of publication of these materials, and are subject to change by Renesas Technology Corp. without notice due to product improvements or other reasons. It is therefore recommended that customers contact Renesas Technology Corp. or an authorized Renesas Technology Corp. product distributor for the latest product information before purchasing a product listed herein.
The information described here may contain technical inaccuracies or typographical errors.
Renesas Technology Corp. assumes no responsibility for any damage, liability, or other loss rising from these inaccuracies or errors.
Please also pay attention to information published by Renesas Technology Corp. by various means, including the Renesas Technology Corp. Semiconductor home page (<http://www.renesas.com>).
 4. When using any or all of the information contained in these materials, including product data, diagrams, charts, programs, and algorithms, please be sure to evaluate all information as a total system before making a final decision on the applicability of the information and products. Renesas Technology Corp. assumes no responsibility for any damage, liability or other loss resulting from the information contained herein.
 5. Renesas Technology Corp. semiconductors are not designed or manufactured for use in a device or system that is used under circumstances in which human life is potentially at stake. Please contact Renesas Technology Corp. or an authorized Renesas Technology Corp. product distributor when considering the use of a product contained herein for any specific purposes, such as apparatus or systems for transportation, vehicular, medical, aerospace, nuclear, or undersea repeater use.
 6. The prior written approval of Renesas Technology Corp. is necessary to reprint or reproduce in whole or in part these materials.
 7. If these products or technologies are subject to the Japanese export control restrictions, they must be exported under a license from the Japanese government and cannot be imported into a country other than the approved destination.
Any diversion or reexport contrary to the export control laws and regulations of Japan and/or the country of destination is prohibited.
 8. Please contact Renesas Technology Corp. for further details on these materials or the products contained therein.
-

RENESAS SALES OFFICES



<http://www.renesas.com>

Refer to "<http://www.renesas.com/en/network>" for the latest and detailed information.

Renesas Technology America, Inc.
450 Holger Way, San Jose, CA 95134-1368, U.S.A
Tel: <1> (408) 382-7500, Fax: <1> (408) 382-7501

Renesas Technology Europe Limited
Dukes Meadow, Millboard Road, Bourne End, Buckinghamshire, SL8 5FH, U.K.
Tel: <44> (1628) 585-100, Fax: <44> (1628) 585-900

Renesas Technology Hong Kong Ltd.
7th Floor, North Tower, World Finance Centre, Harbour City, 1 Canton Road, Tsimshatsui, Kowloon, Hong Kong
Tel: <852> 2265-6688, Fax: <852> 2730-6071

Renesas Technology Taiwan Co., Ltd.
10th Floor, No.99, Fushing North Road, Taipei, Taiwan
Tel: <886> (2) 2715-2888, Fax: <886> (2) 2713-2999

Renesas Technology (Shanghai) Co., Ltd.
Unit2607 Ruijing Building, No.205 Maoming Road (S), Shanghai 200020, China
Tel: <86> (21) 6472-1001, Fax: <86> (21) 6415-2952

Renesas Technology Singapore Pte. Ltd.
1 Harbour Front Avenue, #06-10, Keppel Bay Tower, Singapore 098632
Tel: <65> 6213-0200, Fax: <65> 6278-8001