



SANYO Semiconductors DATA SHEET



LV25200M

— Bi-CMOS IC

Single chip Tuner IC for Car Radio

Overview

LV25200M is a tuner IC for car radio, which incorporates the AM/FM Tuner, PLL, AM/FM Noise Canceller (NC), FM Stereodecoder (MPX), Multipath-noise Rejection Circuit (MRC).

This IC enables development of the low-cost analog tuner for OEM.

Functions

- AM+FM-FE+IF+NC+MPX+MRC+PLL

Features

- World-wide compatible tuners
A single tuner module is enough to supply the world-wide compatible tuners.
FM is compatible with US EURO, Japan bands while AM is compatible with LW, MW, SW, Weather-Band.
With the image cancel mixer incorporated in FM MIX, the external RF AMP can be deleted.
Compatible with RDS. PLL fast locking.
- Self-contained type IF band variable filter incorporated
Detects any neighboring interfering station and varies the IF filter band, enabling superior selectivity characteristic.
- Auto alignment EEPROM necessary
FM RF, VCO, Null-voltage, Mute-on, Mute-ATT, SNC, HCC, Station detector, Gain AGC sensitivity, CCB bus compatible
- Reduced parts quantity
Parts quantity reduced from our conventional products
- Other functions
AM noise canceller (genuine compatible)

- CCB is a registered trademark of SANYO Electric Co., Ltd.
- CCB is SANYO Semiconductor's original bus format. All bus addresses are managed by SANYO Semiconductor for this format.

■ Any and all SANYO Semiconductor Co.,Ltd. products described or contained herein are, with regard to "standard application", intended for the use as general electronics equipment (home appliances, AV equipment, communication device, office equipment, industrial equipment etc.). The products mentioned herein shall not be intended for use for any "special application" (medical equipment whose purpose is to sustain life, aerospace instrument, nuclear control device, burning appliances, transportation machine, traffic signal system, safety equipment etc.) that shall require extremely high level of reliability and can directly threaten human lives in case of failure or malfunction of the product or may cause harm to human bodies, nor shall they grant any guarantee thereof. If you should intend to use our products for applications outside the standard applications of our customer who is considering such use and/or outside the scope of our intended standard applications, please consult with us prior to the intended use. If there is no consultation or inquiry before the intended use, our customer shall be solely responsible for the use.

■ Specifications of any and all SANYO Semiconductor Co.,Ltd. products described or contained herein stipulate the performance, characteristics, and functions of the described products in the independent state, and are not guarantees of the performance, characteristics, and functions of the described products as mounted in the customer's products or equipment. To verify symptoms and states that cannot be evaluated in an independent device, the customer should always evaluate and test devices mounted in the customer's products or equipment.

SANYO Semiconductor Co., Ltd.

TOKYO OFFICE Tokyo Bldg., 1-10, 1 Chome, Ueno, Taito-ku, TOKYO, 110-8534 JAPAN

LV25200M

Specifications

Maximum Ratings at $T_a = 25^\circ\text{C}$

Parameter	Symbol	Conditions	Ratings	Unit
Maximum supply voltage	V_{CC_H} max	PIN 5, 77	8.7	V
	V_{CC_L} max	PIN 21, 27, 50	5.7	V
Maximum input current	V_{IN} max	PIN 17, 18, 19	-0.3 to +5.0	V
Maximum output current	V_O max	PIN 20	-0.3 to +6.5	V
Allowable power dissipation	P_d max	($T_a \leq 85^\circ\text{C}$)	950	mW
Operating temperature	T_{opr}		-40 to +85	$^\circ\text{C}$
Storage temperature	T_{stg}		-40 to +150	$^\circ\text{C}$

Recommended Operating Conditions at $T_a = 25^\circ\text{C}$

Parameter	Symbol	Conditions	Ratings	Unit
Recommended supply voltage	V_{CC_H}	PIN 5, 66, 75, 76, 77	8.0	V
	V_{CC_L}	PIN 21, 27, 50	5.0	V
Operating supply voltage range	V_{Ccop_H}	PIN 5, 66, 75, 76, 77	7.5 to 8.5	V
	V_{Ccop_L}	PIN 21, 27, 50	4.5 to 5.5	V
Input High level voltage	V_{IH}	PIN 17, 18, 19	2.5 to 4.0	V
Input Low level voltage	V_{IL}	PIN 17, 18, 19	0 to 0.8	V
Input amplitude voltage	V_{IN}	PIN 17, 18, 19	0 to 4.0	Vp-p
Input pulse width	$t_{\phi W}$	PIN 19	0.45 or more	μs
Setup time	T_{setup}	PIN 17, 18, 19	0.45 or more	μs
Hold time	T_{hold}	PIN 17, 18, 19	0.45 or more	μs

Package Dimensions

unit : mm (typ)

3255

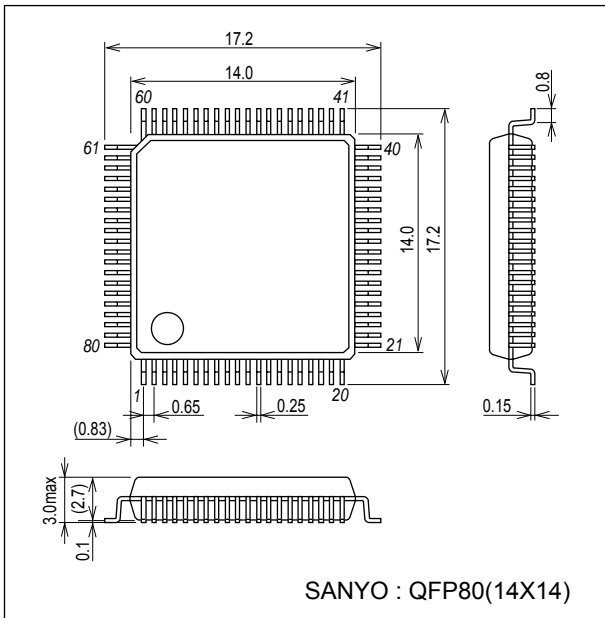

Reset at Power ON

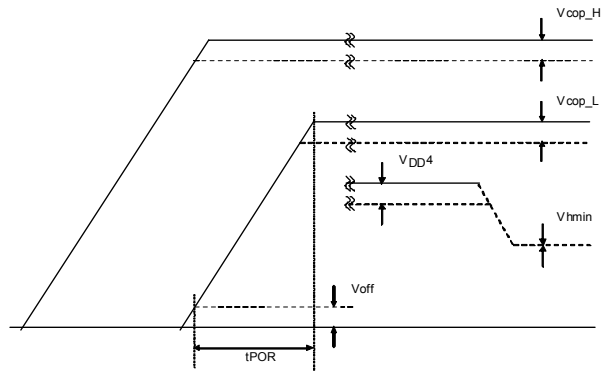

Recommended Operating Conditions at $T_a=25^\circ\text{C}$, GND=0V

Parameter	Symbol	Conditions	Ratings	Unit
Operating supply voltage	V_{cop_H}	PIN 5, 66, 75, 76, 77	7.5 to 8.5	V
	V_{cop_L}	PIN 21, 27, 50	4.5 to 5.5	V
Internal logic voltage	V_{DD4}	PIN 13	3.7 to 4.3	V
Internal register hold voltage	V_{hmin}	PIN 13, Design reference value	V_{DD4} to 2.2	V
Internal register reset voltage	V_{off}	PIN 27, 50, Design reference value	0 to 0.2	V
Internal register reset power ON time	t_{POR}	PIN 27, 50, Design reference value	30 to 3000	μs

LV25200M

AC Characteristics

Operating Characteristics at Ta=25°C, VCC=8.0V, VDD=5.0V

with the designated measuring circuit outside standard.

Except that this measurement was made with the IC socket [Yamaichi Denki Kogyo Co., Ltd. IC51-0644-807].

Audio filter: IHF BPF used

[FM characteristics] FM FE MIX input (NO-Dummy)

	Parameter	Symbol	Conditions	CCB Command							min	typ	max	Unit
				IN1	IN2	IN3-1	IN3-2	IN3-3	IN3-4	IN3-5				
1-1	Current drain -8V	Icco-8V	No input FM mode I5+I66+I75+I76+I77	19	37	25	25	25	25	25	50	62	74	mA
1-2	Current drain -5V	Icco-5V	No input FM mode I21+I27+I50	19	37	25	25	25	25	25	44.5	51	58	mA
1-3	Demodulation output	Vo-FM	98.1MHz, 60dBμV, 1kHz, 100%mod, pin 25	19	37	25	25	25	25	25	220	277	350	mVrms
1-4	Pin 52 RDS demodulation output	Vo-52	98.1MHz, 60dBμV, 1kHz, 100%mod, pin 52	19	37	25	25	25	25	25	270	340	425	mVrms
1-5	Channel balance	CB	98.1MHz, 60dBμV, 1kHz, pins 25 and 26	19	37	25	25	25	25	25	-1	0	1	dB
1-6	Total harmonic distortion factor	THD-Fmmono (1)	98.1MHz, 60dBμV, 1kHz, 100%mod, pin 25	19	37	25	25	25	25	25		0.2	1	%
1-7	Total harmonic distortion	THD-Fmmono (2)	98.1MHz, 60dBμV, 1kHz, 150%mod, pin 25	19	37	25	25	25	25	25		0.3	2.5	%
1-8	Signal to noise ratio (MONO)	S/N-FM-MONO	98.1MHz, 60dBμV, 1kHz, 100%mod,	19	37	25	25	25	25	25	60	67		dB
1-9	Signal to noise ratio (ST)	S/N-FM-ST	98.1MHz, 60dBμV, 1kHz, 100%mod, pin 25, pilot=10%	19	37	25	25	25	25	25	54	58		dB
1-10	AM suppression ratio	AMR	98.1MHz, 60dBμV, 1kHz, 100%mod, 30% in AM mode, fm=1kHz, pin 25	19	37	25	25	25	25	25	54	61		dB
1-11	Muting attenuation (1)	Att-1	98.1MHz, 60dBμV, 1kHz, with V33=0→2V, pin 25 attenuation	19	37	25	25	14	25	25	-30	-25	-20	dB
1-12	Muting attenuation (2)	Att-2	98.1MHz, 60dBμV, 1kHz, with V33=0→2V, pin 25 attenuation	19	37	25	35	25	25	25	-20	-16	-11.2	dB
1-13	Muting attenuation (3)	Att-3	98.1MHz, 60dBμV, 1kHz, with V33=0→1V, pin 25 attenuation	19	37	25	35	25	25	25	-11	-6	-1	dB
1-14	Separation	Separation	98.1MHz, 60dBμV, mod=30%, pilot=10%, pin 25 output ratio [IN3-5 D0-5] Separation control adj	19	37	25	25	25	25	25	27	38		dB
1-15	Stereo ON level	ST-ON	Pilot demodulation at which V39<0.5V is established	19	37	25	25	25	25	25	1.9	4.1	6.3	%
1-16	Stereo OFF level	ST-OFF	Pilot demodulation at which V39>3.5V is established	19	37	25	25	25	25	25	1	3		%
1-17	Main distortion factor	THD-Main L	98.1MHz, 60dBμV, L+R=90%, pilot=10%, pin 25	19	37	25	25	25	25	25		0.3	1.2	%
1-18	SNC output attenuation	AttSNC	98.1MHz, 60dBμV, L-R=90%, pilot=10%, V28=3V→0.6V, pin 25; standard for single block	19	37	25	25	25	25	25	-10	-6	-2	dB
1-19	HCC output attenuation (1)	FM HCC	98.1MHz, 60dBμV, 10kHz, L+R=90%, pilot=10%, V29=3V→0.6V, pin 25; standard for single block	19	37	25	25	25	25	25	-6	-3	-0.5	dB
1-20	HCC output attenuation (2)	FM HCC	98.1MHz, 60dBμV, 10kHz, L+R=90%, pilot=10%, V29=3V→0.1V, pin 25; standard for single block	19	37	25	25	25	25	25	-14.5	-10.5	-6.5	dB
1-21	Input limiting voltage	Vi-lim	98.1MHz, 60dBμV, 30%mod, MIX input at which the input reference output is down by -3dB, V42=0V, V29=0V, with MUTE=OFF	19	37	25	25	25	25	25	-6	-1	1	dBμV
1-22	Muting sensitivity	Vi-mute	MIX input level at V42=1V, non-mod	19	37	25	25	25	25	25	0.1	5	9.9	dBμV

Continued on next page.

LV25200M

Continued from preceding page.

	Parameter	Symbol	Conditions	CCB Command						min	typ	max	Unit	
				IN1	IN2	IN3-1	IN3-2	IN3-3	IN3-4					IN3-5
1-23	SD sensitivity	SD-senFM	MIX input level at which SD pin is ON, shifter-adj, non-mod	20	37	25	25	25	25	25	20	25	30	dB μ V
	IF count sensitivity	IF-count-sens.FM	IF count sensitivity at MIX input, non-mod	20	37	25	19	25	25	25	16			dB μ V
1-24	S-meter DC output	VSMFM-1	No input, pin 38 DC output non-mod	19	37	25	25	25	25	25			0.5	V
		VSMFM-2	10dB μ V, pin 38 DC output non-mod	19	37	25	25	25	25	25		0.75		V
		VSMFM-3	30dB μ V, pin 38 DC output non-mod [IN3-2 D0-4] S-meter shift-adj	19	37	25	A1	25	25	25	1.8	1.85	1.9	V
		VSMFM-4	50dB μ V, pin 38 DC output non-mod	19	37	25	25	25	25	25		3.3		V
		VSMFM-5	80dB μ V, pin 38 DC output non-mod	19	37	25	25	25	25	25			4.8	V
1-24	S-meter AC pin DC output	VSMFM-A1	No input, pin 40 DC output non-mod	19	37	25	25	25	25	25			0.45	V
		VSMFM-A2	10dB μ V, pin 40 DC output non-mod	19	37	25	25	25	25	25		0.85		V
		VSMFM-A3	30dB μ V, pin 40 DC output non-mod	19	37	25	25	25	25	25	1.51	1.78	2.1	V
		VSMFM-A4	50dB μ V, pin 40 DC output non-mod	19	37	25	25	25	25	25		3.05		V
		VSMFM-A5	80dB μ V, pin 40 DC output non-mod	19	37	25	25	25	25	25			4.8	V
1-25	S-meter inclination standard - 1	S-curve1	Holds [IN3-2 D0-4] data, which was obtained by deducting (VSMFM-2) from VSM (VSMFM-3)	19	37	25	25	25	25	25	0.85	1.1	1.4	V
1-26	S-meter inclination standard - 2	S-curve2	Holds [IN3-2 D0-4] data, which was obtained by deducting (VSMFM-3) from VSM (VSMFM-4)	19	37	25	25	25	25	25	1	1.45	1.9	V
1-27	Mute drive output	VMUTE-60	60dB μ V, pin 42 output DC output non-mod	19	37	25	25	25	25	25		0.15	0.3	V
1-28	Noise convergence - 1	FM NOISE-20	60dB μ V.98.1MHz, 30%mod, input reference, output level of the input -20dB μ V, MUTE=OFF(42pin=GND)	19	37	25	25	25	25	25	-14	-9	-4	dB
1-29	N-AGC ON input	VNAGC	98.1MHz, non-mod, MIX input level at which pin 1 becomes 0.6V or more	19	37	25	25	33	25	25	66	75	84	dB μ V
1-30	W-AGC ON input	VWAGC	98.1MHz, non-mod, pin 38 =1.0V applied (Keyed on), MIX input level at which pin 1 becomes 0.6V or more	19	37	25	25	35	25	25	82	90	98	dB μ V
1-31	Image obstruction ratio-1		Removal amount of 108.1M +21.4MHz	21	37	25	25	25	25	25	15			dB
1-32	Image obstruction ratio-2		Removal amount of 90M -21.4MHz	28	37	25	25	25	25	25	15			dB
	SD bandwidth - 1	BW-mute1	98.1MHz, non-mod, 50dB μ V, Bandwidth at which SD pin is turned ON	20	37	23	25	37	25	25	70	100	130	kHz
	SD bandwidth - 2	BW-mute2	98.1MHz, non-mod, 50dB μ V, Bandwidth at which SD pin is turned ON	20	37	23	25	38	25	25	130	200	270	dB
1-33	Conversion gain	A.V.	98.1MHz, 60dB μ V, non-mod, FECF output	28	37	25	25	25	25	25	85	130	200	mVrms

Continued on next page.

LV25200M

[FM IF Filter characteristics] FM IF input

	Parameter	Symbol	Conditions	CCB Command							min	typ	max	Unit
				IN1	IN2	IN3-1	IN3-2	IN3-3	IN3-4	IN3-5				
2-1	IF variable filter gain-narrow band	FIL-G-N	70dB μ V, pin 54 AC (450kHz) output non-mod, After CF adjustment, fit in through BW/G adjustment. Narrow-Fix MODE	19	37	21	25	25	25	25	79	84	89	
2-2	IF variable filter	FIL-BW-N	Pin 54 -AC output monitor. Confirm the 2dB or more level down at the \pm 25kHz point with reference to the center frequency of 450kHz. -3dB bandwidth. Narrow-Fix MODE	19	37	21	25	25	25	25	2			dB
2-3	IF variable filter	FIL-BW-W	Pin 54-AC output monitor. Confirm no level down exceeding 3 dB at the \pm 80kHz point with reference to the center frequency of 450kHz. -3dB bandwidth. Wide-Fix MODE	19	37	23	25	25	25	25			3	dB

[NC block] NC input (48pin), S-meter AC input (40pin)

	Parameter	Symbol	Conditions	CCB Command							min	typ	max	Unit
				IN1	IN2	IN3-1	IN3-2	IN3-3	IN3-4	IN3-5				
3-1	FM NC gate time	FM τ GATE	NC input, pulse cycle=1kHz, 38pin=2V applied, pulse width=1 μ s, at 100mVp-o pulse input (after MVCO adjustment)	19	37	25	25	25	25	25	36	40	44	μ s
3-2	FM NC noise sensitivity	SN-DETOU	NC input (pin 48), 38pin=2V applied, measure the pulse input level at which the noise canceller starts operation, pulse cycle=1kHz, pulse width=1 μ s	19	37	25	25	25	25	25	17	30	43	mVp-o
3-3	FM NC noise sensitivity	SN-Vsm	S-meter (AC) input (pin 40), 38pin=0V applied, measure the pulse input level at which the noise canceller starts operation, pulse cycle=1kHz, pulse width=1 μ s	19	37	25	25	25	25	25		46		mVp-o
3-4	AM NC gate time	AM τ GATE(1)	S-meter (AC) input (pin 40), pulse cycle=1kHz, pulse width=1 μ s, measurement at pin 33. 38pin=1.5	36	37	26	26	26	26	26	345	450	555	μ s
3-5	AM NC noise sensitivity	SN	S-meter (AC) input (pin 40), measure the pulse input level at which the noise canceller starts operation, pulse cycle=1kHz, pulse width=1 μ s	36	37	26	26	26	26	26		24		mVp-o

[Multipath-noise rejection circuit] MRC input (pin 41)

	Parameter	Symbol	Conditions	CCB Command							min	typ	max	Unit
				IN1	IN2	IN3-1	IN3-2	IN3-3	IN3-4	IN3-5				
4-1	MRC output	VMRC	Pin 39 voltage when 3.5 V is applied to V38	19	37	25	25	25	25	25	2.76	2.96	3.16	V
4-2	MRC operation level	MRC-ON	SG (AG5) out level when pin 38 =5V and pin 39=2.6V, f=70kHz	19	37	25	25	25	25	25	50	71	100	mVrms

LV25200M

AM characteristics | AM AMANT input

	Parameter	Symbol	Conditions	CCB Command								min	typ	max	Unit
				IN1	IN2	IN3-1	IN3-2	IN3-3	IN3-4	IN3-5					
5-1	Practical sensitivity	S/N-30	1MHz, 30dBμV, fm=1kHz, 30%mod, pin 25	36	37	26	26	26	26	26	26	20			dB
5-2	Detection output	Vo-AM	1MHz, 74dBμV, fm=1kHz, 30%mod, pin 25	36	37	26	26	26	26	26	26	84	105	131	mVrms
5-3	AGC-F.O.M	VAGC-FOM	1MHz, 74dBμV, output reference, input width at which the output decreases by 10dB, pin 25	36	37	26	26	26	26	26	26	50	54.5	59	dB
5-4	Signal-to-noise ratio	S/N-AM	1MHz, 74dBμV, fm=1kHz, 30%mod	36	37	26	26	26	26	26	26	51	60		dB
5-5	Total harmonic distortion ratio - 1	THD-AM-1	1MHz, 74dBμV, fm=1kHz, 80%mod	36	37	26	26	26	26	26	26		0.3	1	%
5-6	Total harmonic distortion ratio - 2	THD-AM-2	1MHz, 120dBμV, fm=1kHz, 80%mod	36	37	26	26	26	26	26	26		0.5	1.5	%
5-7	AM HCC output attenuation	AM HCC	1MHz, 74dBμV, fm=4kHz, 30%mod, V29=3V→0.6V, 25pin	36	37	26	26	26	26	26	26	5	9	13	dB
5-8	S-meter DC output	VSMAMDC-1	No input, 38pin DC output	36	37	26	26	26	26	26	26	0	0.1	0.5	V
		VSMAMDC-2	1MHz, 30dBμV, non-mod, 38pin DC output	36	37	26	26	26	26	26	26	1.2	1.5	1.9	V
		VSMAMDC-3	1MHz, 130dBμV, non-mod, 38pin DC output	36	37	26	26	26	26	26	26	2.85	3.6	4.9	V
5-9	S-meter AC output	VSMAMAC-1	No input, 40pin DC output	36	37	26	26	26	26	26	26		0	0.5	V
		VSMAMAC-2	1MHz, 74dBμV, non-mod, 40pin DC output	36	37	26	26	26	26	26	26		0.75		V
5-10	Wide band AGC sensitivity	W-AGCsen1	1.4MHz, input at V48=0.7V	36	37	26	26	26	26	26	26	82	92	102	dBμV
5-11	SD sensitivity	SD-senAM	1MHz, ANT input level at which the SD pin is turned ON	37	37	26	26	26	26	26	26	25	30	35	dBμV

Function

1. AM / FM front-end block

FM Image rejection Mixer		
AM Double balance Mixer		
Pin diode drive AGC output		
Keyed AGC adjustment	4 bit DAC	
Differential IF amplifier		
Wide AGC sensitivity setting	4 bit DAC	
Narrow AGC sensitivity setting	4 bit DAC	
Local oscillator	160MHz to 260MHz	
FM Local OSC divider	1/1 1/2 1/3	
AM Local OSC divider	1/10, 1/8, 1/6, 1/4	

2. FM IF block

IF Limiter Amplifier 6 stages		
S-meter shifter	5 bit DAC	
S-meter output (DC/AC)		
Multipath detector (dedicated FM S-meter)		
Quadrature detector	Vnull adj-5bit, QDP adj-4bit	450kHz
AF preamplifier (Audio mute)		
AFC output		
Variable bandwidth control	CF adj-5bit DAC BW/Gain adj-5bit DAC Gain adj-3bit DAC (for setting filter)	

Continued on next page.

LV25200M

Continued from preceding page.

Soft mute setting	5 bit DAC	
Mute attenuation setting	6 bit DAC	-0.5dB to -25dB
IF counter buffer (FM circuits)	10.7MHz	
SD (IF counter buffer activation level) setting	5 bit DAC	
SD output (active-high) (also used by AM circuits)		
IF output Driver for DSP (AF out, non-muting)		
SD: Station Detector		
IF Gain	4 bit DAC	

3. AM Block (back end of AM tuner)

Double balance 2 nd mixer		
IF amplifier	4 bit DAC	
AM detector		
RF Narrow AGC	4 bit DAC	
Wide AGC	4 bit DAC	
Pin diode drive AGC output		
S-meter output	2 bit DAC	
IF counter buffer		450kHz
SD (IF counter buffer activation level) setting	5 bit DAC	
SD output (active-high)		
Detector output frequency adjusting pin (Low-cut, De-emphasis)		

4. FM NC

High-Pass-Filter (1st-order)		
Delay circuit of Low-Pass-Filter (4th order)		
Noise-AGC (Sensitivity:2 Bit-control)	2 bit DAC	
Pilot signal compensation		
Noise sensitivity setting		
Modulation index		

5. AM NC

AM Noise canceller Gate-Time	6 bit DAC	
AM Noise canceller OFF Level	5 bit DAC	

6. MPX

VCO (Free-Run Frequency:6 Bit-control)	6 bit DAC	304kHz
Level following pilot canceller	2 bit (3 step adj.)	
Automatic stereo/mono switching		
VCO oscillator stop (AM mode)		
Forced monaural		
Stereo indicator (active-low)		
Anti-birdie filter (f=114kHz, 190kHz)		
SNC (stereo noise control)	5 bit DAC	
HCC (high-cut control)	5 bit DAC	
Separation setting	6 bit	64 steps

7. MRC (Multipath-noise Rejection Circuit)

Noise Amplifier Gain (sensitivity setting)	2 bit	4 step
DC Level-Shifter		
SNC driving		
Time constant control circuit	2 bit	4 step

LV25200M

Pin Function

Pin No.	Function name	Block
1	FM-ANT-D	FE
2	FM-RF-AGC	FE
3	GND (FE)	---
4	AM-MIX-IN2	AM
5	OSC-V _{CC}	---
6	AM/FM-OSC (B)	FE
7	AM/FM-OSC (C)	FE
8	PLL-LPF	PLL
9	FM FET	PLL
10	AM FET	PLL
11	CPAM	PLL
12	CPFM	Common
13	PLL V _{DD}	MPX
14	ST/SD, VCO monitor and PLL-TEST	PLL
15	Sep.-ADJ.	MPX
16	GND (Analog)	---
17	CE	PLL
18	DI	PLL
19	CL	PLL
20	DO	PLL
21	V _{CC} (X'tal)	---
22	X'tal-OUT	X'tal
23	X'tal-IN	X'tal
24	GND (X'tal)	---
25	MPX-L-OUT	MPX
26	MPX-R-OUT	MPX
27	V _{CC} 5V (Digital)	---
28	SNC	MPX
29	HCC	MPX
30	MPX-PCO1	MPX
31	MPX-PCO2	MPX
32	GND (Digital)	---
33	NC-Gate- monitor	NC
34	MPX-PLL-IN	MPX
35	HCC capacity	MPX
36	Noise-Sens.	NC
37	Noise-AGC	NC
38	V _{sm} (Main)	IF
39	MRC-OUT	MRC
40	V _{sm} 2 (Sub)	IF

Pin-No.	Function name	Block
41	MRC-AC-IN	MRC
42	Mute-Drive	IF
43	AFC	IF
44	QD-Cap.	IF
45	QD-Cap.	IF
46	V _{ref} 2.7V	Common
47	IF-Det-OUT	IF
48	NC-IN	NC
49	Mod.-Index	NC
50	V _{CC} 5V (Analog)	---
51	Interfering signal detected	FIL
52	RDS-OUT	IF
53	PLL-TEST	PLL
54	IF Filter OUT	FIL
55	AM-IFAGC (load for V _t setting)	AM
56	Pilot-Det/AM-LC	MPX/AM
57	IF-AGC	AM
58	AM-W-AGC	AM
59	AM-RF-AGC (BYPASS)	AM
60	AM-IF-IN	AM
61	AM-IN-IN2	AM
62	FM-IF-IN (BYPASS)	IF
63	FM-IF-IN AM-2nd-MIX-IN	IF AM
64	AM-RF-AGC	AM
65	1st-IF-OUT	FE
66	AM-MIX2-OUT	AM
67	V _{ref} 4.9V	Common
68	RF-DAC1	FM
69	AM-2nd-MIX-IN (BYPASS)	AM
70	RF-DAC2	FM
71	IF-IN(BIAS)	FE
72	FM-1st-IF-IN	FE
73	AM-ANT-D and PLL-TEST	AM
74	N-AGC-IN	FE
75	MIX-OUT	FE
76	MIX-OUT	FE
77	V _{CC} (8V)	---
78	AM-MIX-IN	AM
79	FM-MIX-IN	FE
80	FM-MIX-IN	FE

LV5200M

Block Diagram

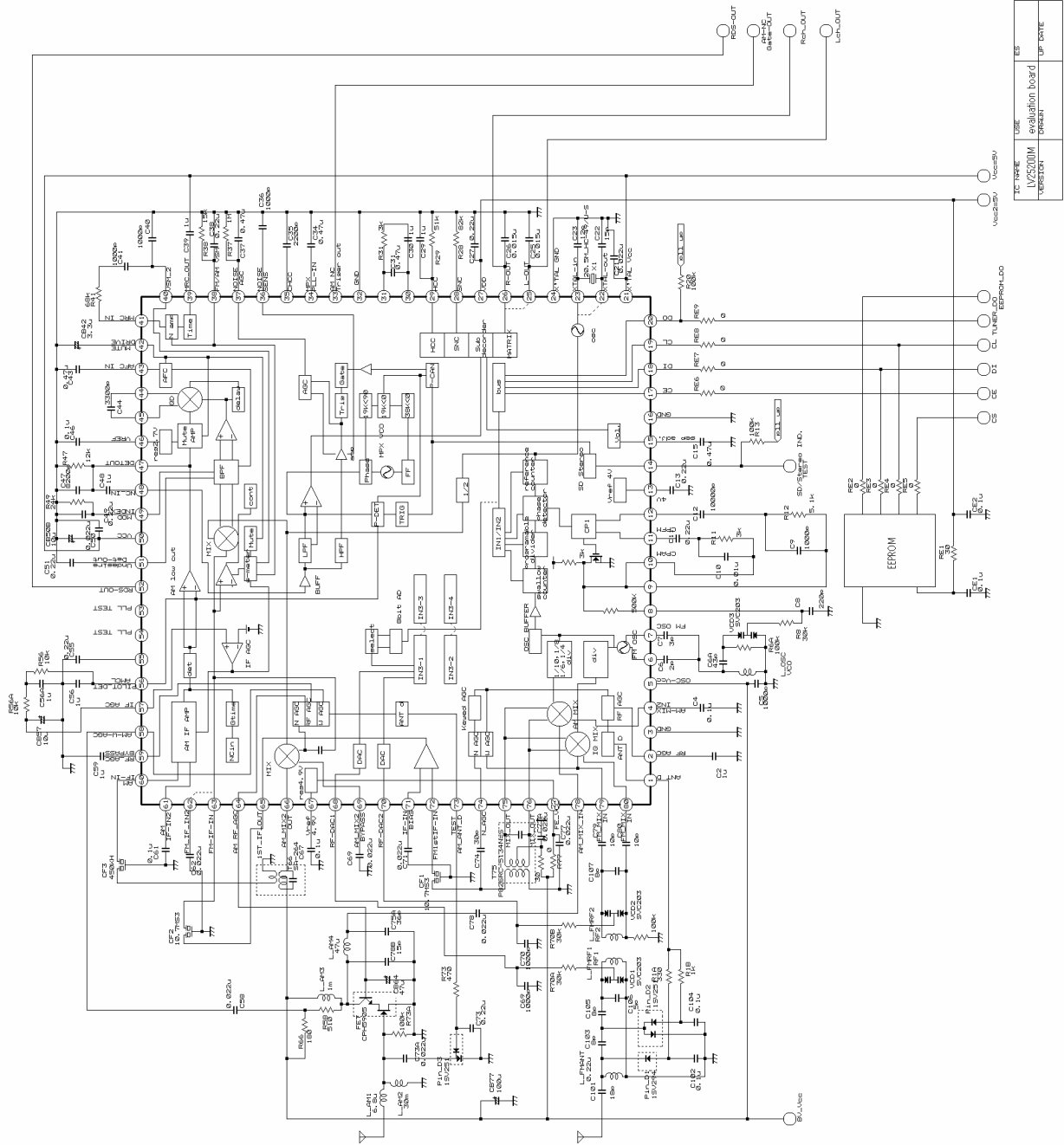

PC BOARD	USER	REV
LV5200M	Application board	1.0
LV5200M	REV01	1/17/2016

LV25200M

Pin Discription

Unit (Resistance: Ω , Capacitance: F)

Pin	Function	Discription	Internal Equivalent Circuit
1	Antenna Damping Drive pin	Pin 2: Antenna damping current flows when the RF AGC voltage becomes $V_{CC}-V_{be}$.	
2	RF AGC	RF AGC voltage. Voltage=Hi (around 8V) with AGC OFF. The voltage lowers when a level is inserted into the AGC circuit. AGC is applied at the voltage of $V_{CC}-V_{be}$.	
3	FE.GND		FE GND(F.E.)
5	OSC V_{CC}	OSC dedicated V_{CC}	8V V_{CC} (VCO.)
6 7	FM/AM OSC IN FM/AM OSC OUT	OSC pin	

Continued on next page.

LV25200M

Continued from preceding page.

Unit (Resistance: Ω, Capacitance: F)

Pin	Function	Discription	Internal Equivalent Circuit
8	Tuning voltage output LPF output	FM: PLL filter formed with pins 9 to 12 (Pins 10 and 11 to be left OPEN)	
9	FET for FM	AM: PLL filter formed with pins 10 and 11. In this case, the low pass filter is formed with the internal impedance (100kΩ) and external capacity.	
10	FET for AM	Simultaneous use of AM and FM filters (pins 9 to 12) is possible through mode changeover. In this case, internal impedance (100kΩ) is short-circuited.	
11	Charge pump for FM		
12	Charge pump for AM		
13	V _{DD} for PLL	PLL regulator output (4V)	
14	AM/FM SD pin STEREO indicator & VCO Monitor	STEREO indicator at reception: Low: STEREO High: MONO At SEEK: AM/FM SD ON=High OFF=Low Pin 14 output is output from DO (for SD information output). VCO monitor (at IN3-5 D6=H) Saw-tooth wave of MPX-VCO frequency is output, which is monitored for VCO adjustment (Adjust with IN3-5 D0-5.)	
15	Separation adjustment pin	The input level of sub-decoder is varied through BIT control. (The output level of MONO and MAIN remains unchanged.)	

Continued on next page.

LV25200M

Continued from preceding page.

Unit (Resistance: Ω , Capacitance: F)

Pin	Function	Discription	Internal Equivalent Circuit
16	N.C, MPX, MRC And PLL-GND		
17	CE	Pin to set the high level during serial data input (D1) to LV25200M or serial data output (DO).	
18	DI	Input pin for serial data for transfer from the controller to LV25200M	
19	CL	Clock for synchronization with the data during serial data input (DI) to LV25200M or serial data output (DO)	
20	DO	Output pin of serial data to be transferred from LV25200M to the controller	
21	V _{CC} 5V	X'tal-OSC dedicated V _{CC}	
22	X'tal-OSC-OUT	Connect X'tal oscillator for 20.5MHz between pins 22 and 23.	
23	X'tal-OSC-IN	Connect capacitors, each 12pF, between pins 22 and 23 and GND.	
24	GND	X'tal-OSC dedicated GND	

Continued on next page.

LV25200M

Continued from preceding page.

Unit (Resistance: Ω, Capacitance: F)

Pin	Function	Discription	Internal Equivalent Circuit
25 26	MPX output (LEFT) MPX output (RIGHT)	MPX output Output impedance changed over with the de-Emphasis changeover Bit (IN3-4 D20) Low=3.3kΩ High=5kΩ (The figure in the right shows a case of 5kΩ.) (50/75μs changeover with the external capacity of 0.015μF)	
27	V _{CC} 2 (5V)	V _{CC} for PLL and Digital system V _{CC}	
28	SNC control input pin	With the pin 28 input voltage, the attenuation of (L-R) Decode is controlled. ↓ Decrease Separation. ↓ The noise felt in the Stereo mode is reduced. (Threshold can be controlled with 5Bit.)	
29	HCC control input pin	With the pin 29 input voltage, attenuation of the high pass component is controlled. ↓ At weak input, high pass is cut to reduce the noise feeling. Same control for FM/AM HCC (f characteristics changed over automatically between AM and FM modes.) (Threshold can be controlled with 5Bit.)	
30 31	Phase-Comparator for MPX		
32	GND		
33	NC-Gate Trigger-OUT	Normal: High (V _{DD} potential) Gate: Low (0V) Note) Monitor output is not made unless the Bit setting of Pilot-Cancel is set to 11 (PICAN=OFF).	

Continued on next page.

LV25200M

Continued from preceding page.

Unit (Resistance: Ω , Capacitance: F)

Pin	Function	Discription	Internal Equivalent Circuit
34	MPX-PLL input	<p>LPF formed with internal resistance 30kΩ and pin 34 external capacity</p> <p>↓</p> <p>HPF formed by subtracting the above LPS passage signal from the Composite signal.</p> <p>↓</p> <p>Supply to MPX-PLL circuit</p>	
35	HCC capacitor pin	<p>With pin 35 external capacity, High-Cut frequency characteristics are set.</p> <p>The value of internal resistance R35 is changed over in AM/FM mode: FM mode: R35=30kΩ AM mode: R35=100kΩ</p>	
36	Noise detection sensitivity	<p>With the noise sensitivity setting pin of pin 36, set the medium electric field (about 50dBμ). Then, with the AGC-Adj pin of pin 37, carry out setting in the weak field (20 to 30dBμ).</p>	
37	AGC adj pin		
38	AM/FM S-meter (DC)	<p>Current drive type S-meter output</p> <p>Pin 38: Eliminate the AC component by external capacity</p>	
40	AM/FM S-meter (AC)	<p>Pin 40: Leaves the AC component (Pin for NC noise extraction and for multipath noise extraction)</p>	

Continued on next page.

LV25200M

Continued from preceding page.

Unit (Resistance: Ω, Capacitance: F)

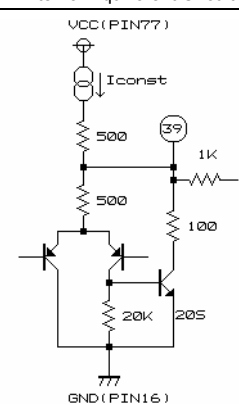
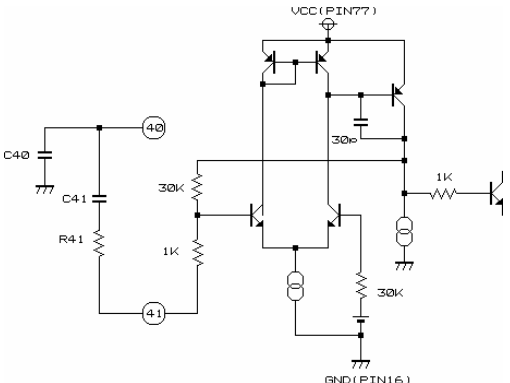
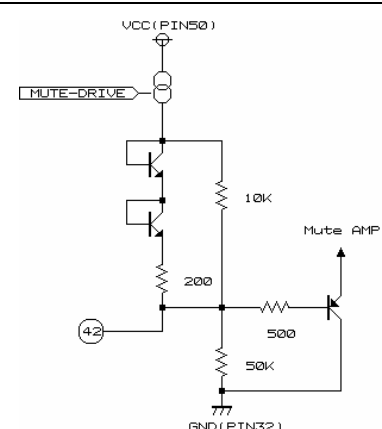
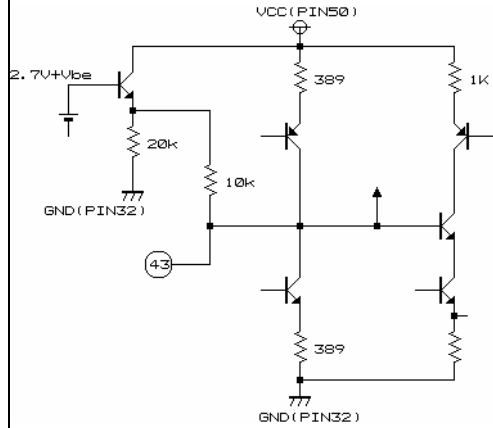
Pin	Function	Discription	Internal Equivalent Circuit
39	MRC output (for SNC Control)	<p>Time constant for Multipath-Noise Detector is determined with the following: 100Ω and $C2$ during discharge I_{const} and $C2$ during charge</p> <p>I_{const} can be changed over with 2Bit (MRC-Time-Constant)</p>	
41	MRC AC input pin	<p>From AC-S-meter (pin 40), enter the AC component. Amp-Gain, and frequency characteristics are determined with $C41$, $(R41+1k\Omega$ [internal resistance]) and $30k\Omega$ (internal resistance).</p> <p>Amp-Gain can be controlled with 2Bit.</p>	
42	Mute Drive	<p>① The MUTE time constant is determined as follows by CR:</p> <ul style="list-style-type: none"> • Attack time $TA=10k\Omega (R1) \times C42$ • Release time $TR=50k\Omega (R2) \times C42$ <p>② Noise convergence adjustment</p> <p>③ MUTE OFF function MUTE is turned OFF when pin 42 is short-circuited with GND.</p>	
43	AFC	<p>Null voltage As compared with pin 46 2.7V</p>	

Continued on next page.

LV25200M

Continued from preceding page.

Unit (Resistance: Ω, Capacitance: F)

Pin	Function	Discription	Internal Equivalent Circuit
44 45	FM DET capacity	FM quadrature detection capacity	
46	Vreg (2.7V)	2.7V regulator	
47	FM/AM DET OUT	AM/FM detection output Output impedance Low impedance in the FM mode 10kΩ in the AM mode	
48	Noise canceller input	Noise Canceller Input Input impedance 50kΩ	

Continued on next page.

LV25200M

Continued from preceding page.

Unit (Resistance: Ω , Capacitance: F)

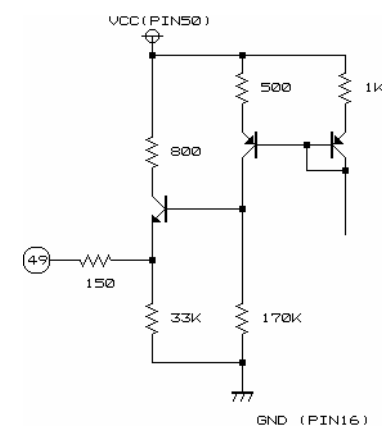
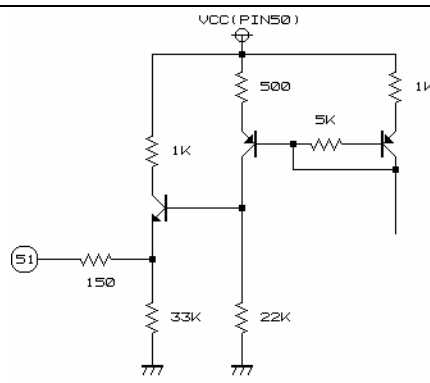
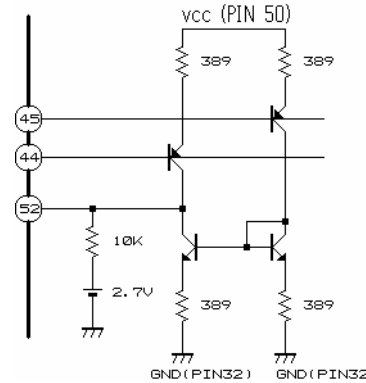
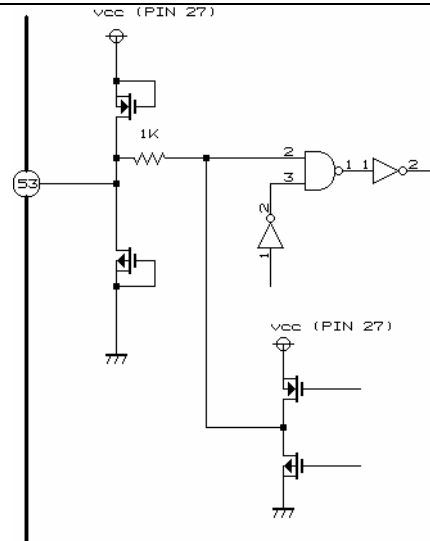
Pin	Function	Discription	Internal Equivalent Circuit
49	MOD INDEX	Set the detection output level as DC output. C49 is the DC smoothing capacitor. (Used for control of the IF band variable filter)	
50	V _{CC} (5V) Analog system		
51	Undesire Det	Set the over-100kHz detection output noise level as DC output. C51 is the DC smoothing capacitor. (Used for control of the IF band variable filter)	
52	RDS OUT	FM detection output that is not passed through Mute AMP. * This output is not affected by the time constant due to muting.	
53	PLL TEST PIN	Test pin	

Continued on next page.

LV25200M

Continued from preceding page.

Unit (Resistance: Ω, Capacitance: F)

Pin	Function	Discription	Internal Equivalent Circuit
54	PLL TEST PIN (IF band variable filter output)	IN3-1 Monitor • IF_FIL IF band variable filter output monitor (AC output)	
55	AM IFAGCBYPASS	IF AGC voltage DC smoothing capacitor pin	
57	AM IF AGC	TR1; Time constant changeover at Seek switch diode; 2.2μF Discharging diode ① At reception Time constant depends on the external LPF composition of pins 55 to 57. ② Seek Time constant is 57pin (C57) × 10Ω	
56	AM LC FM Pilot Det	AM LC; Frequency characteristics of unnecessary voice band of 100Hz or less is changed to produce the clear sound in the AM mode. AM LC f characteristic; $F_c = 1 / (2\pi * 2.5K * C56)$ Pilot Det; Insertion of 1MΩ between pin 56 and GND causes the forced MONO mode. For C56, 0.47μF or more is recommended.	
58	AM W-AGC	AMP for W-AGC pickup incorporated	

Continued on next page.

LV25200M

Continued from preceding page.

Unit (Resistance: Ω , Capacitance: F)

Pin	Function	Discription	Internal Equivalent Circuit
59	AM RFAGC BYPASS	RF AGC rectifier capacitor Determination of the distortion ratio during low-frequency modulation Increase C59 and C64; Distortion → improved Response → slow Decrease C59 and C64; Distortion → worse Response → quick	
64	RF AGC	RF AGC rectifier capacitor Determination of distortion ratio during low-frequency modulation Increase C59 and C64; Distortion → improved Response → slow Decrease C59 and C64; Distortion → worse Response → quick	
60 61	AM IF AMP IN	AM 450kHz AMP input Input impedance=2k Ω	
62 63	FM 2 nd MIX input FM AMP input	FM 2 nd MIX 10.7MHz → 450kHz FM AMP (10.7MHz) AMP for S-meter voltage	
65	AM/FM 1 st IF AMP OUTPUT	Output impedance=330 Ω	

Continued on next page.

LV25200M

Continued from preceding page.

Unit (Resistance: Ω , Capacitance: F)

Pin	Function	Description	Internal Equivalent Circuit
66	AM 2 nd MIX OUT	MIX coil connected to pin 66 MIX output must be connected to (V _{CC}).	
67	Vref 4.9V	4.9V regulator	
63 69	AM 2 nd MIX input /AM AGC pick up	AM MIX input AMP for AM N-AGC pickup Input impedance 10k Ω	
68	RF DAC1	8bit DAC	
70	RF DAC2	8bit DAC	
71 72	FM/AM 1 st IF AMP IN	10.7M AMP for FM/AM Input impedance=330 Ω	

Continued on next page.

LV25200M

Continued from preceding page.

Unit (Resistance: Ω , Capacitance: F)

Pin	Function	Discription	Internal Equivalent Circuit
73	AM antenna damping output	For pin diode drive I73=6mA ANT damping current	
74	FM N-AGC IN	AMP for N-AGC pickup incorporated	
75 76	FM/AM 1 st MIX OUT	FM/AM MIX OUT (common)	
77	V _{CC} (8V) FM FE, AM		
78	AM 1 st MIX IN	AM MIX input Input impedance=10k Ω	
79 80	FM MIX IN FM W-AGC pick up	FM MIX input FM W-AGC pickup Input impedance=10k Ω	

FM/AM level Diagram

[FM]

Input Condition : FM 98.1MHz, mod off, 30dBuV

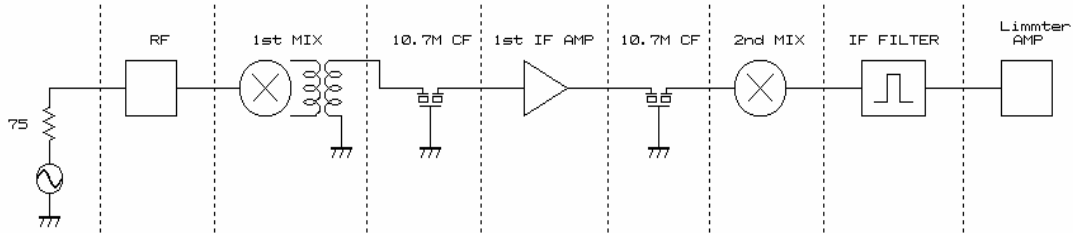

	RF	1st MIX	10.7M CF	1st IF AMP	10.7M CF	2nd MIX	IF FILTER	
FM LEVEL	-2	28	-1.5	26.5	-3	14	0	dB

[AM]

Input Condition : AM 1MHz, mod off, 50dBuV

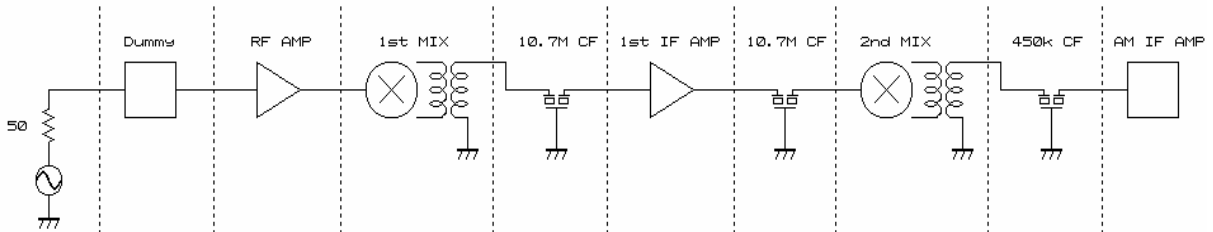

	JIS Dummy	RF AMP	1st MIX	10.7M CF	1st IF AMP	10.7M CF	2nd MIX	450k CF	
AM LEVEL	-18.1	26.8	5.7	-0.8	8	-3.9	10	-2.4	dB

LV25200M

Serial Bus Data Timing

CE: Chip enable
CL: Clock

DI: Input data
DO: Output data

<<CL stopped at "L" level >>

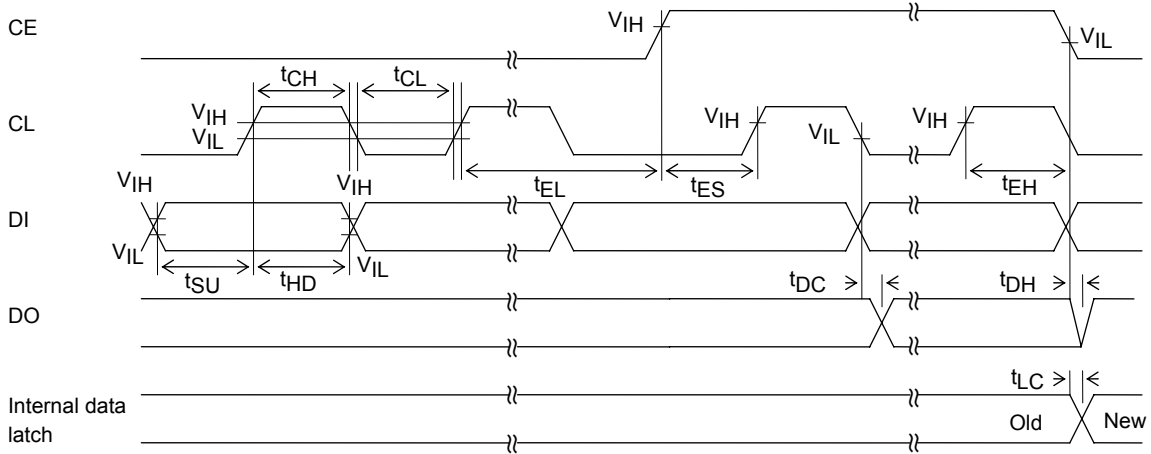

<<CL stopped at "H" level >>

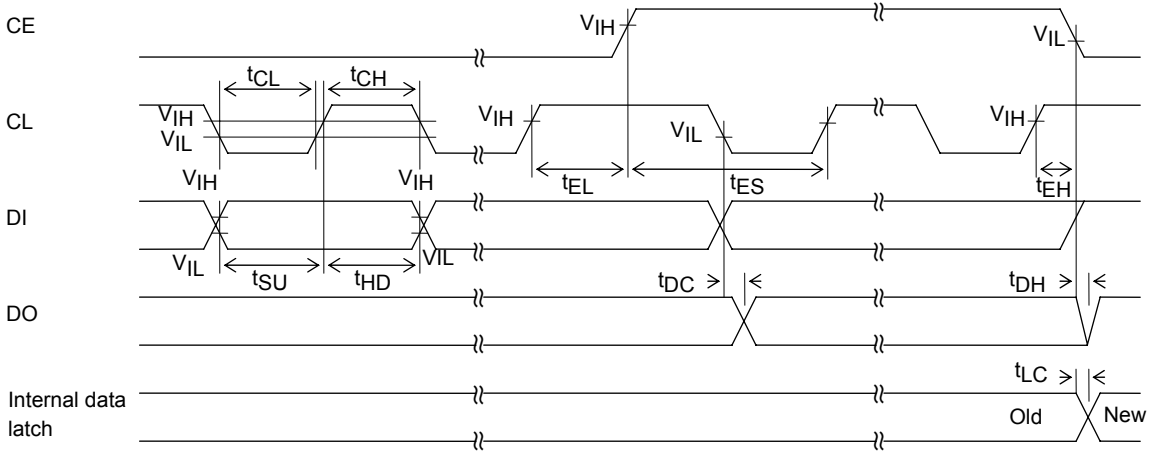

Parameter	Symbol	Pin	Conditions	min	typ	max	unit
Data setup time	t_{SU}	DI, CL		0.45			μs
Data hold time	t_{HD}	DI, CL		0.45			μs
Clock L level time	t_{CL}	CL		0.45			μs
Clock H level time	t_{CH}	CL		0.45			μs
CE wait time	t_{EL}	CE, CL		0.45			μs
CE setup time	t_{ES}	CE, CL		0.45			μs
CE hold time	t_{EH}	CE, CL		0.45			μs
Data latch change time	t_{LC}					0.45	μs
Data output time	t_{DC}	DO, CL	Varies depending on the pull-up resistance			0.2	μs
	t_{DH}	DO, CE					

LV25200M

Serial Data I/O Method

This is the Sanyo Audio IC serial bus format. Data I/O is made with CCB (Computer Control Bus).

LV25200M is the 8-bit address type CCB.

	I/O mode	Address								Description
		B0	B1	B2	B3	A0	A1	A2	A3	
[1]	IN1	0	0	0	1	0	1	0	0	<ul style="list-style-type: none"> Control data input (serial data input) mode. PLL setting 32-bit data input
[2]	IN2	1	0	0	1	0	1	0	0	<ul style="list-style-type: none"> Control data input (serial data input) mode. PLL setting 32-bit data input
[3]	IN3	1	0	0	1	0	1	1	0	<ul style="list-style-type: none"> Control data input (serial data input) mode, set by the tuner 32-bit data input with sub-address
[4]	OUT	0	1	0	1	0	1	0	0	<ul style="list-style-type: none"> Output data (serial data output) mode Output of data corresponding to the clock amount. Max 48 bits

i) Serial data input (IN1/IN2/IN3) $t_{SU}, t_{HD}, t_{ES}, t_{EL}, t_{EH}, > 0.45\mu s$ $t_{LC} < 0.45\mu s$

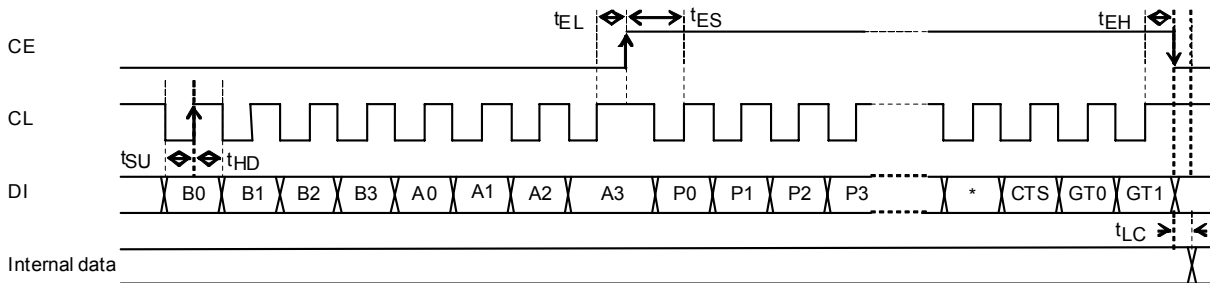

ii) Serial data output (OUT) $t_{SU}, t_{HD}, t_{ES}, t_{EL}, > 0.45\mu s$ $t_{DC}, t_{DH} < 0.2\mu s$ (*1)

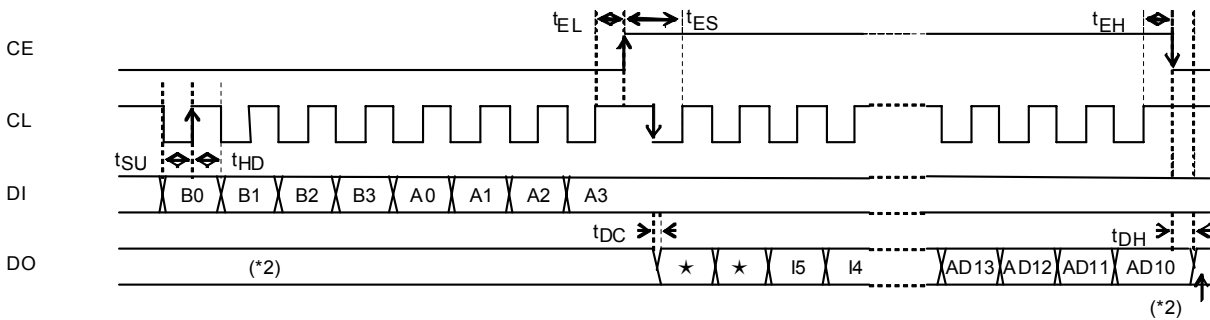

(*1) As the DO pin is the Nch open drain pin, so that the data change time varies depending on the pull-up resistance and substrate capacity.

(*2) Normally, keep the DO pin in the OPEN state.

LV25200M

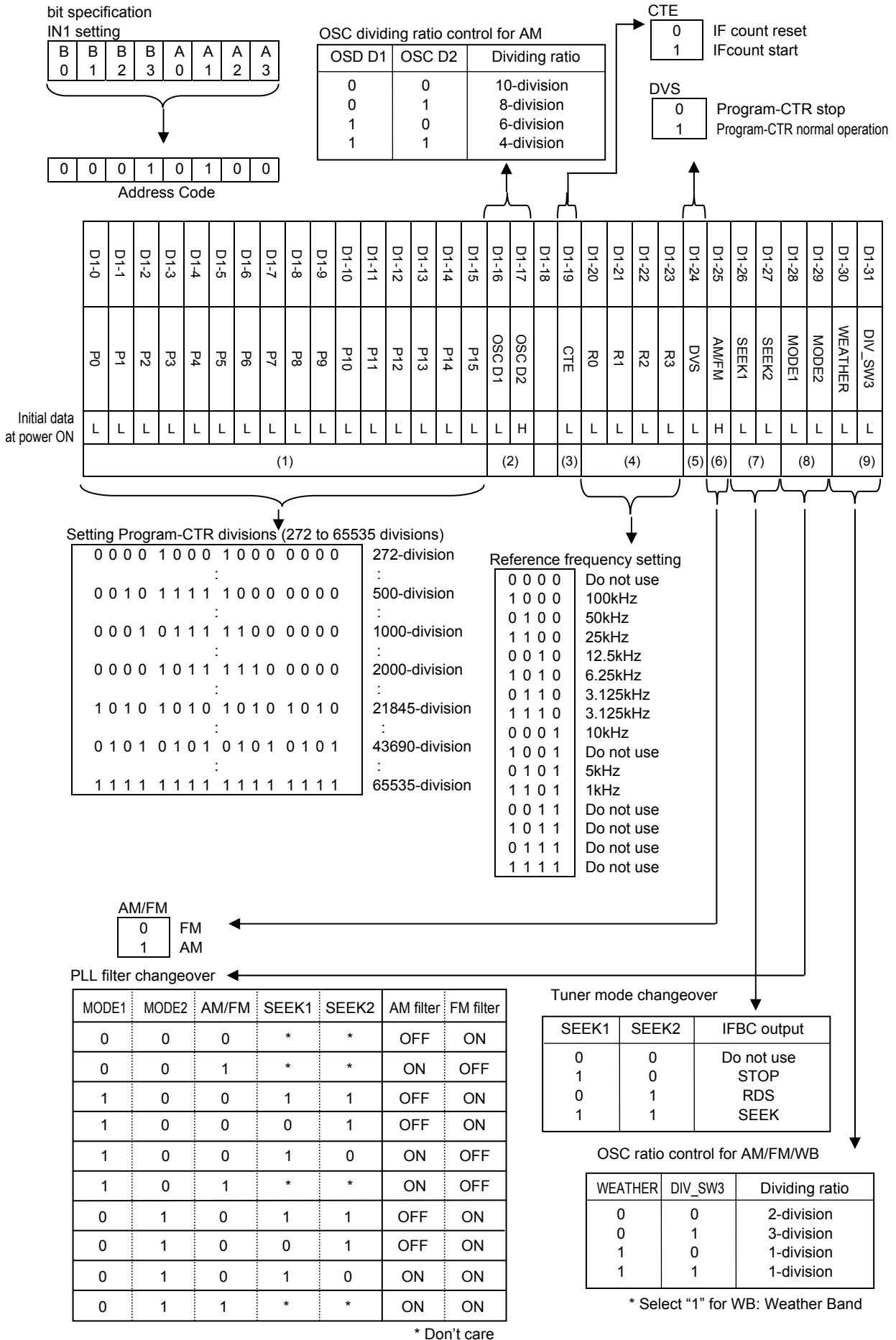

LV25200M

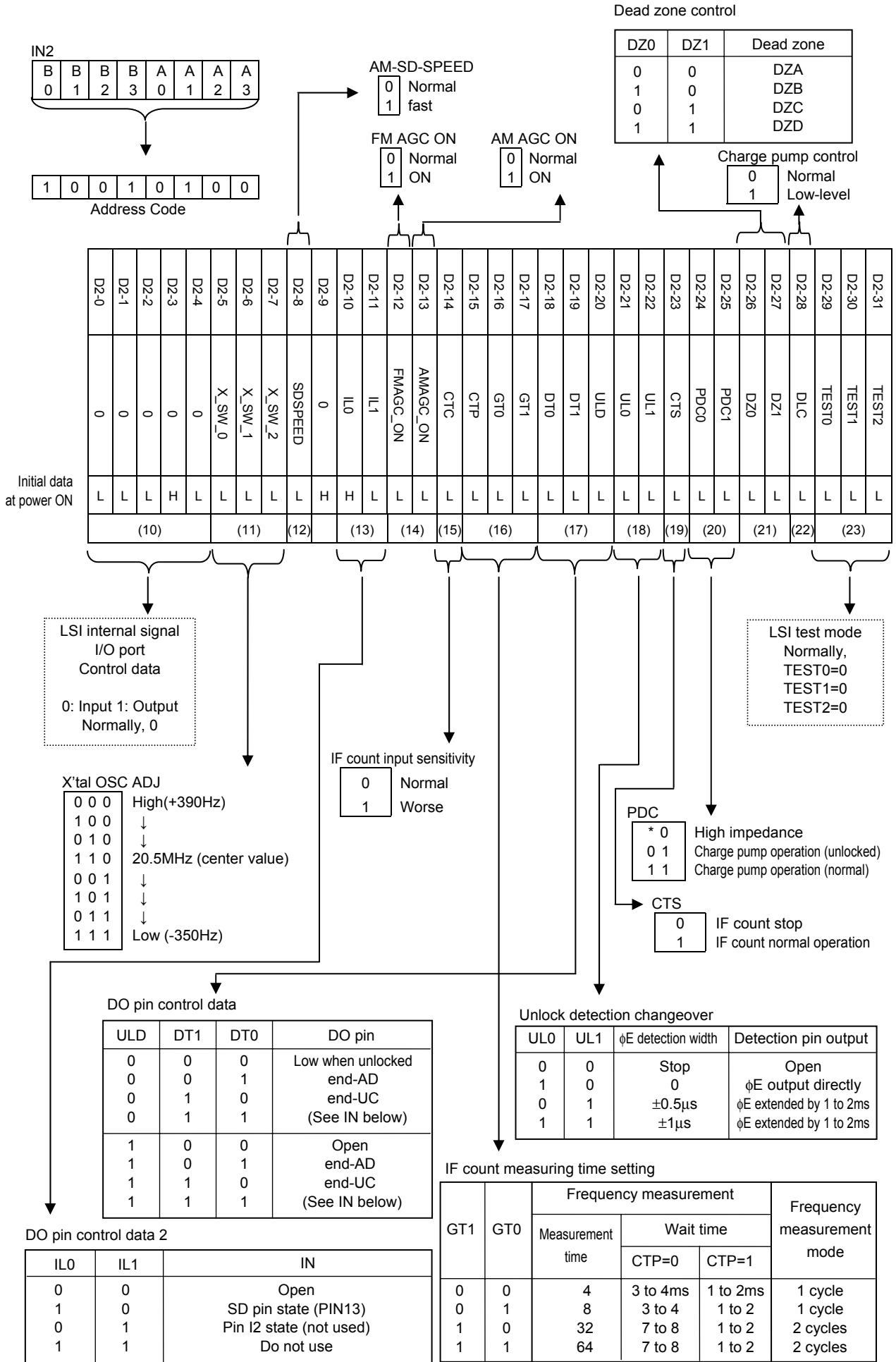

LV25200M

IN3-2 tuner setting2

Address 69h, Subaddress[0 0 1]

B	B	B	B	A	A	A	A
0	1	2	3	0	1	2	3

1	0	0	1	0	1	1	0
---	---	---	---	---	---	---	---

Address Code

0	0	1
---	---	---

Sub Address Code

Initial data at power ON

D32-0	D32-1	D32-2	D32-3	D32-4	D32-5	D32-6	D32-7	D32-8	D32-9	D32-10	D32-11	D32-12	D32-13	D32-14	D32-15	D32-16	D32-17	D32-18	D32-19	D32-20	D32-21	D32-22	D32-23	D32-24	D32-25	D32-26	D32-27	D32-28	D32-29	D32-30	D32-31
L	L	L	L	L	L	L	L	L	L	L	L	L	L	L	L	L	L	L	L	L	L	L	L	L	L	L	L	L	L	L	
(31)				(32)				(33)				(34)				(35)				(36)				(37)	(65)						

FM Mute-ON-Adj.
/AM NC stop

00000	0.135
10000	↓
01000	↓
11000	↓
00100	↓
10100	↓
01100	↓
.	↓
10011	↓
01011	↓
11011	↓
00111	↓
10111	↓
01111	↓
11111	1.7

Weak input Mute changeover
(Mute-ANG)

000	0.2
100	↓
010	↓
110	↓
001	↓
101	↓
011	↓
111	0.8

Tuner OFF mode

0	Normal
1	Tuner-OFF

FM-IF-Gain
/AM NC Gain

0000	2.2
1000	↓
0100	↓
1100	↓
0010	↓
1010	↓
0110	↓
1110	↓
0001	↓
1001	↓
0101	↓
1101	↓
0011	↓
1011	↓
0111	↓
1111	2.8

S-Meter Shift(TSOOUT)

00000	177μA
10000	↓
01000	↓
11000	↓
00100	↓
10100	↓
01100	↓
11100	↓
.	↓
01011	↓
11011	↓
00111	↓
10111	↓
01111	↓
11111	221μA

FM Mute-ATT.
/AM NC Gate-Time

000000	0.1	0.14
100000	↓	↓
010000	↓	↓
110000	↓	↓
001000	↓	↓
101000	↓	↓
011000	↓	↓
.	↓	↓
100111	↓	↓
010111	↓	↓
110111	↓	↓
001111	↓	↓
101111	↓	↓
011111	↓	↓
111111	1.89	2.7

FM/AM SD Adjust (at SEEK)
NC-AGC threshold voltage setting (at reception)

00000	0.25
10000	↓
01000	↓
11000	↓
00100	↓
10100	↓
01100	↓
11100	↓
.	↓
01011	↓
11011	↓
00111	↓
10111	↓
01111	↓
11111	2.65

LV25200M

IN3-3 tuner setting2

Address 69h, Subaddress[0 1 0]

B	B	B	B	A	A	A	A
0	1	2	3	0	1	2	3

1	0	0	1	0	1	1	0
---	---	---	---	---	---	---	---

Address Code

0	1	0
---	---	---

Sub Address Code

Initial data at power ON

D33-0	D33-1	D33-2	D33-3	D33-4	D33-5	D33-6	D33-7	D33-8	D33-9	D33-10	D33-11	D33-12	D33-13	D33-14	D33-15	D33-16	D33-17	D33-18	D33-19	D33-20	D33-21	D33-22	D33-23	D33-24	D33-25	D33-26	D33-27	D33-28	D33-29	D33-30	D33-31
L	L	L	L	L	L	L	L	L	L	L	L	L	L	L	L	L	L	L	L	L	L	L	L	L	L	L	L	L	L	L	L
(38)				(39)				(40)				(41)				(42)				(43)				(44)		(45)		(65)			

FM/AM W-AGC Sensitivity

0000	0.14
1000	
0100	
1100	
0010	
1010	
0110	
1110	
0001	
1001	
0101	
1101	
0011	
1011	
0111	
1111	2.57

Keyed-AGC /AM-IF-Gain

0000	0.14
1000	
0100	
1100	
0010	
1010	
0110	
1110	
0001	
1001	
0101	
1101	
0011	
1011	
0111	
1111	2.2

Null Voltage

00000	0.87
10000	
01000	
11000	
00100	
10100	
01100	
.	
.	
10011	
01011	
11011	
00111	
10111	
01111	
11111	1.8

Vref 2.7V ADJ

00	Low
10	Typ
01	Little High
11	High

Mute-ATT-SW/AM-Vsm-Shift

00	Low(Steep inclination)
10	
01	
11	High(Gentle inclination)

FM/AM N-AGC Sensitivity

0000	0.2
1000	
0100	
1100	
0010	
1010	
0110	
1110	
0001	
1001	
0101	
1101	
0011	
1011	
0111	
1111	2.5

SD detection band width setting (at FM-SEEK)
Band variable filter start point setting (FM reception)

0000	0.54
1000	
0100	
1100	
0010	
1010	
0110	
1110	
0001	
1001	
0101	
1101	
0011	
1011	
0111	
1111	2.19

QD P-ADJ

0000	0.83
1000	
0100	
1100	
0010	
1010	
0110	
1110	
0001	
1001	
0101	
1101	
0011	
1011	
0111	
1111	1.39

LV25200M

IN3-5 tuner setting2

Address 69h, Subaddress[1 0 0]

B	B	B	B	A	A	A	A
0	1	2	3	0	1	2	3

1	0	0	1	0	1	1	0
---	---	---	---	---	---	---	---

Address Code

1	0	0
---	---	---

Sub Address Code

D35-0	D35-1	D35-2	D35-3	D35-4	D35-5	D35-6	D35-7	D35-8	D35-9	D35-10	D35-11	D35-12	D35-13	D35-14	D35-15	D35-16	D35-17	D35-18	D35-19	D35-20	D35-21	D35-22	D35-23	D35-24	D35-25	D35-26	D35-27	D35-28	D35-29	D35-30	D35-31
L	L	L	L	L	L	L	L	L	L	L	L	L	L	L	L	L	L	L	L	L	L	L	L	L	L	L	L	L	L	L	L
(58)						(59)	(60)	(61)						(62)						(63)	(64)	(65)									

Initial data at power ON

VCO ON
During measurement: Hi

HCC SW	1	FM
	0	AM

MRC Sensitivity	00	Low
	10	↓
	01	↓
	11	High

MRC Time constant (Attack: Release Time)	00	Short
	10	
	01	
	11	Long

MPX VCO

(Free-Run Freq. Control)

000000	Freq=Low
100000	↓
010000	↓
110000	↓
001000	↓
101000	↓
011000	↓
111000	↓
.	↓
.	↓
010111	↓
110111	↓
001111	↓
101111	↓
011111	↓
111111	Freq=High

"Filter-Wide fixed" sensitivity/AM-RF-AGC Amp threshold (steep inclination side)

0000	0.37
1000	
0100	
1100	
0010	
1010	
0110	
1110	
0001	
1001	
0101	
1101	
0011	
1011	
0111	
1111	2.04

Filter-initial adjustment

D12-14	Gain	Gain adjustment
D15-19	CF	CF adjustment
D20-24	BW/G	BW/G adjustment

"Gain adjustment"		
D12	D13	D14
111		Gain Low
011		
101		
000		Typical
100		
010		
110		Gain High

"CF adjustment"		
D15	...	D19
11111		CF Left Shift
01111		
10111		
.		
.		
01001		
10001		
00000		Typical
10000		
01000		
.		
.		
10110		
01110		
11110		CF Right Shift

"BW/G adjustment"		
D20	...	D24
11111		BW(W)G↓
01111		
10111		
.		
.		
01001		
10001		
00000		Typical
10000		
01000		
.		
.		
10110		
01110		
11110		BW(N)G↑

BIT Control Standard: Reference Value

1. FM S-meter shifter

LSB		MSB			Function
D32-0	D32-1	D32-2	D32-3	D32-4	
0	0	0	0	0	Vsm(DC)=1.85V: +8dB
					↑
0	0	0	0	1	Vsm(DC)=1.85V: 0dB
					↓
1	1	1	1	1	Vsm(DC)=1.85V: -7dB

2-1. FM Mute-ON-adj

LSB		MSB			Function
D32-5	D32-6	D32-7	D32-8	D32-9	
0	0	0	0	0	-3dB Limiting sens: -6dB
					↑
1	1	1	1	0	-3dB Limiting sens: 0dB
					↓
1	1	1	1	1	-3dB Limiting sens: +10dB

2-2. AM NC stop

LSB		MSB			Function
D32-5	D32-6	D32-7	D32-8	D32-9	
0	0	0	0	0	Vsm (DC) for AM NC STOP=0.3V
					↑
0	0	0	0	1	Vsm (DC) for AM NC STOP=2.3V
					↓
1	1	1	1	1	Vsm (DC) for AM NC STOP=4.2V

3-1. FM Mute-ATT

LSB		MSB				Function
D32-10	D32-11	D32-12	D32-13	D32-14	D32-15	
0	0	0	0	0	0	MUTE attenuation: -0.5dB
						↑
0	0	0	0	0	1	MUTE attenuation: -13dB
						↓
1	1	1	1	1	1	MUTE attenuation: -25dB

3-2. AM NC Gate-Time

LSB		MSB				Function
D32-10	D32-11	D32-12	D32-13	D32-14	D32-15	
0	0	0	0	0	0	INPUT=60dBμV: 1000μs
						↑
0	0	0	0	0	1	INPUT=60dBμV: 350μs
						↓
1	1	1	1	1	1	INPUT=60dBμV: 200μs

4. FM weak input Mute changeover

(FM Mute-ON-adj:0000)

LSB		MSB	Function
D32-16	D32-17	D32-18	
0	0	0	INPUT=-20dBμV V42: 1.45V
			↑
1	1	0	INPUT=-20dBμV V42: 2.0V
			↓
1	1	1	INPUT=-20dBμV V42: 2.7V

LV25200M

5-1. FM SD Adjust

LSB		MSB			Function
D32-19	D32-20	D32-21	D32-22	D32-23	
0	0	0	0	0	SD on level: -19dB
					↑
0	0	0	0	1	SD on level: 0dB
					↓
1	1	1	1	1	SD on level: +20dB

5-2. AM SD Adjust

LSB		MSB			Function
D32-19	D32-20	D32-21	D32-22	D32-23	
0	0	0	0	0	SD on level: -13dB
					↑
0	0	0	0	1	SD on level: 0dB
					↓
1	1	1	1	1	SD on level: +25dB

6-1. FM IF-Gain

LSB		MSB		Function
D32-24	D32-25	D32-26	D32-27	
0	0	0	0	450kHz limit AMP: -6dB
				↑
0	0	0	1	450kHz limit AMP: 0dB
				↓
1	1	1	1	450kHz limit AMP: +6dB

7-1. FM W-AGC

LSB		MSB		Function
D33-0	D33-1	D33-2	D33-3	
0	0	0	0	W-AGC on level: -2dB
				↑
0	0	0	1	W-AGC on level: 0dB
				↓
1	1	1	1	W-AGC on level: +2dB

7-2. AM W-AGC

LSB		MSB		Function
D33-0	D33-1	D33-2	D33-3	
0	0	0	0	N-AGC on level: -9.5dB
				↑
0	0	0	1	N-AGC on level: 0dB
				↓
1	1	1	1	W-AGC on level: +6dB

8-1. FM N-AGC

LSB		MSB		Function
D33-4	D33-5	D33-6	D33-7	
0	0	0	0	N-AGC on level: -9dB
				↑
0	0	0	1	N-AGC on level: 0dB
				↓
1	1	1	1	N-AGC on level: +6dB

8-2. AM N-AGC

LSB		MSB		Function
D33-4	D33-5	D33-6	D33-7	
0	0	0	0	N-AGC on level: -10dB
				↑
0	0	0	1	N-AGC on level: 0dB
				↓
1	1	1	1	N-AGC on level: +6.5dB

LV25200M

9-1. FM Keyed-AGC

LSB		MSB		Function
D33-8	D33-9	D33-10	D33-11	
0	0	0	0	V38 for Keyed AGC ON: 0.12V ↑
0	0	0	1	V38 for Keyed AGC ON: 1.2V ↓
1	1	1	1	V38 for Keyed AGC ON: 2.1V

9-2. AM IF-Gain

LSB		MSB		Function
D33-8	D33-9	D33-10	D33-11	
0	0	0	0	AM 450kHz AMP Gain: -7.5dB ↑
0	0	0	1	AM 450kHz AMP Gain: 0dB ↓
1	1	1	1	AM 450kHz AMP Gain: -4.5dB

10-1. FM Mute-ATT-SW

LSB	MSB	Function
D33-25	D33-26	
0	0	MUTE attenuation at V42=1V: -6dB
1	0	MUTE attenuation at V42=1V: -8dB
0	1	MUTE attenuation at V42=1V: -13dB
1	1	MUTE attenuation at V42=1V: -19dB

10-2. AM Vsm-shifter

LSB	MSB	Function
D33-25	D33-26	
0	0	Vsm(DC)=1.5V ANT IN: 30dB μ V
1	0	Vsm(DC)=1.5V ANT IN: 38dB μ V
0	1	Vsm(DC)=1.5V ANT IN: 45dB μ V
1	1	Vsm(DC)=1.5V ANT IN: 55dB μ V

11-1. FM SNC DAC

LSB		MSB			Function
D34-6	D34-7	D34-8	D34-9	D34-10	
0	0	0	0	0	SEPARATION=15dB INPUT: -26dB
0	0	0	1	0	SEPARATION=15dB INPUT: -6dB
0	0	0	0	1	SEPARATION=15dB INPUT: 0dB
0	0	0	1	1	SEPARATION=15dB INPUT: +5dB
1	1	1	1	1	SEPARATION=15dB INPUT: +11dB

12-1. FM HCC DAC

LSB		MSB			Function
D34-11	D34-12	D34-13	D34-14	D34-15	
0	0	0	0	0	V29 at 10kHz mod, -6dB: 0.4V ↑
0	0	0	0	1	V29 at 10kHz mod, -6dB: 0.85V ↓
1	1	1	1	1	V29 at 10kHz mod, -6dB: 1.3V

12-2. AM HCC DAC

LSB		MSB			Function
D34-11	D34-12	D34-13	D34-14	D34-15	
0	0	0	0	0	V29 at 4kHz mod, -6dB: 0.04V ↑
0	0	0	0	1	V29 at 4kHz mod, -6dB: 0.82V ↓
1	1	1	1	1	V29 at 4kHz mod, -6dB: 1.3V

13-1. MRC Time constant

LSB	MSB	Function
D35-27	D35-28	
0	0	Pin 39 output current: 2.9 μ A
1	0	Pin 39 output current: 2.2 μ A
0	1	Pin 39 output current: 1.5 μ A
1	1	Pin 39 output current: 0.8 μ A

LV25200M

Description Of Control Data

No.	Control block/data	Description	Related data																																																																																					
(1)	Programmable divider data P0 to P15	<p>□ Data to set the dividing ratio of the programmable divider. Binary value with P0 as LSB and P15 as MSB</p>	AM/FM OSC D1,D2																																																																																					
(2)	AM OSC dividing ratio OSC D1,OSC D2	<p>□ OSC dividing ratio determination for AM OSC D1 and OSC D2</p> <table border="1" style="margin-left: 20px;"> <thead> <tr> <th>OSC D1</th> <th>OSC D2</th> <th>Dividing ratio</th> </tr> </thead> <tbody> <tr> <td>0</td> <td>0</td> <td>10-division</td> </tr> <tr> <td>0</td> <td>1</td> <td>8-division</td> </tr> <tr> <td>1</td> <td>0</td> <td>6-division</td> </tr> <tr> <td>1</td> <td>1</td> <td>4-division</td> </tr> </tbody> </table>	OSC D1	OSC D2	Dividing ratio	0	0	10-division	0	1	8-division	1	0	6-division	1	1	4-division	AM/FM P0 to P15																																																																						
OSC D1	OSC D2	Dividing ratio																																																																																						
0	0	10-division																																																																																						
0	1	8-division																																																																																						
1	0	6-division																																																																																						
1	1	4-division																																																																																						
(3)	General-purpose counter measurement start control CTE	<p>□ General-purpose counter measurement start data</p> <p>CTE =1: Count start =0: Count reset</p>	CTS GT0,GT1 CTP CTC																																																																																					
(4)	Reference divider data R0 to R3	<p>□ Reference frequency (fref) selection data</p> <table border="1" style="margin-left: 20px;"> <thead> <tr> <th>R3</th> <th>R2</th> <th>R1</th> <th>R0</th> <th>Reference frequency (kHz)</th> </tr> </thead> <tbody> <tr> <td>0</td> <td>0</td> <td>0</td> <td>0</td> <td>Do not use</td> </tr> <tr> <td>0</td> <td>0</td> <td>0</td> <td>1</td> <td>100</td> </tr> <tr> <td>0</td> <td>0</td> <td>1</td> <td>0</td> <td>25</td> </tr> <tr> <td>0</td> <td>0</td> <td>1</td> <td>1</td> <td>25</td> </tr> <tr> <td>0</td> <td>1</td> <td>0</td> <td>0</td> <td>12.5</td> </tr> <tr> <td>0</td> <td>1</td> <td>0</td> <td>1</td> <td>6.25</td> </tr> <tr> <td>0</td> <td>1</td> <td>1</td> <td>0</td> <td>3.125</td> </tr> <tr> <td>0</td> <td>1</td> <td>1</td> <td>1</td> <td>3.125</td> </tr> <tr> <td>1</td> <td>0</td> <td>0</td> <td>0</td> <td>10</td> </tr> <tr> <td>1</td> <td>0</td> <td>0</td> <td>1</td> <td>Do not use</td> </tr> <tr> <td>1</td> <td>0</td> <td>1</td> <td>0</td> <td>5</td> </tr> <tr> <td>1</td> <td>0</td> <td>1</td> <td>1</td> <td>1</td> </tr> <tr> <td>1</td> <td>1</td> <td>0</td> <td>0</td> <td>Do not use</td> </tr> <tr> <td>1</td> <td>1</td> <td>0</td> <td>1</td> <td>Do not use</td> </tr> <tr> <td>1</td> <td>1</td> <td>1</td> <td>0</td> <td>Do not use</td> </tr> <tr> <td>1</td> <td>1</td> <td>1</td> <td>1</td> <td>Do not use</td> </tr> </tbody> </table>	R3	R2	R1	R0	Reference frequency (kHz)	0	0	0	0	Do not use	0	0	0	1	100	0	0	1	0	25	0	0	1	1	25	0	1	0	0	12.5	0	1	0	1	6.25	0	1	1	0	3.125	0	1	1	1	3.125	1	0	0	0	10	1	0	0	1	Do not use	1	0	1	0	5	1	0	1	1	1	1	1	0	0	Do not use	1	1	0	1	Do not use	1	1	1	0	Do not use	1	1	1	1	Do not use	
R3	R2	R1	R0	Reference frequency (kHz)																																																																																				
0	0	0	0	Do not use																																																																																				
0	0	0	1	100																																																																																				
0	0	1	0	25																																																																																				
0	0	1	1	25																																																																																				
0	1	0	0	12.5																																																																																				
0	1	0	1	6.25																																																																																				
0	1	1	0	3.125																																																																																				
0	1	1	1	3.125																																																																																				
1	0	0	0	10																																																																																				
1	0	0	1	Do not use																																																																																				
1	0	1	0	5																																																																																				
1	0	1	1	1																																																																																				
1	1	0	0	Do not use																																																																																				
1	1	0	1	Do not use																																																																																				
1	1	1	0	Do not use																																																																																				
1	1	1	1	Do not use																																																																																				
(5)	Stop of programmable divider DVS	<p>□ DVS=0: PLL-IN pin in IC stopped (pulled-down) 1: PLL-IN pin in IC selected</p> <p> Set number of divisions (N): 272 to 65536 Input frequency range: 120 to 270MHz</p> <p>* For details, refer to "Programmable Divider Composition."</p>	CTS GT0,GT1 CTP CTC																																																																																					
(6)	Tuner mode changeover AM/FM	<p>□ AM/FM mode changeover 1=AM 0=FM</p>	P0 to P15 OSC D1,D2																																																																																					
(7)	Tuner mode changeover SEEK1, SEEK2	<p>□ Data to determine the mode of tuner</p> <table border="1" style="margin-left: 20px;"> <thead> <tr> <th>SEEK1</th> <th>SEEK2</th> <th>IF buffer control output</th> </tr> </thead> <tbody> <tr> <td>0</td> <td>0</td> <td>Do not use</td> </tr> <tr> <td>1</td> <td>0</td> <td>STOP</td> </tr> <tr> <td>0</td> <td>1</td> <td>RDS</td> </tr> <tr> <td>1</td> <td>1</td> <td>SEEK</td> </tr> </tbody> </table>	SEEK1	SEEK2	IF buffer control output	0	0	Do not use	1	0	STOP	0	1	RDS	1	1	SEEK	MODE1, MODE2																																																																						
SEEK1	SEEK2	IF buffer control output																																																																																						
0	0	Do not use																																																																																						
1	0	STOP																																																																																						
0	1	RDS																																																																																						
1	1	SEEK																																																																																						

Continued on next page.

LV25200M

Continued from preceding page.

No.	Control block/data	Description	Related data																																																																													
(8)	PLL filter changeover MODE1,MODE2	<p>□ Data to select/changeover the PLL filter * don't care</p> <table border="1" style="width: 100%; border-collapse: collapse; text-align: center;"> <thead> <tr> <th>MODE1</th> <th>MODE2</th> <th>AM/FM</th> <th>SEEK1</th> <th>SEEK2</th> <th>AM filter</th> <th>FM filter</th> </tr> </thead> <tbody> <tr><td>0</td><td>0</td><td>0</td><td>*</td><td>*</td><td>OFF</td><td>ON</td></tr> <tr><td>0</td><td>0</td><td>1</td><td>*</td><td>*</td><td>ON</td><td>OFF</td></tr> <tr><td>1</td><td>0</td><td>0</td><td>1</td><td>1</td><td>OFF</td><td>ON</td></tr> <tr><td>1</td><td>0</td><td>0</td><td>0</td><td>1</td><td>OFF</td><td>ON</td></tr> <tr><td>1</td><td>0</td><td>0</td><td>1</td><td>0</td><td>ON</td><td>OFF</td></tr> <tr><td>1</td><td>0</td><td>1</td><td>*</td><td>*</td><td>ON</td><td>OFF</td></tr> <tr><td>0</td><td>1</td><td>0</td><td>1</td><td>1</td><td>OFF</td><td>ON</td></tr> <tr><td>0</td><td>1</td><td>0</td><td>0</td><td>1</td><td>OFF</td><td>ON</td></tr> <tr><td>0</td><td>1</td><td>0</td><td>1</td><td>0</td><td>ON</td><td>ON</td></tr> <tr><td>0</td><td>1</td><td>1</td><td>*</td><td>*</td><td>ON</td><td>ON</td></tr> </tbody> </table>	MODE1	MODE2	AM/FM	SEEK1	SEEK2	AM filter	FM filter	0	0	0	*	*	OFF	ON	0	0	1	*	*	ON	OFF	1	0	0	1	1	OFF	ON	1	0	0	0	1	OFF	ON	1	0	0	1	0	ON	OFF	1	0	1	*	*	ON	OFF	0	1	0	1	1	OFF	ON	0	1	0	0	1	OFF	ON	0	1	0	1	0	ON	ON	0	1	1	*	*	ON	ON	AM/FM SEEK1, SEEK2
MODE1	MODE2	AM/FM	SEEK1	SEEK2	AM filter	FM filter																																																																										
0	0	0	*	*	OFF	ON																																																																										
0	0	1	*	*	ON	OFF																																																																										
1	0	0	1	1	OFF	ON																																																																										
1	0	0	0	1	OFF	ON																																																																										
1	0	0	1	0	ON	OFF																																																																										
1	0	1	*	*	ON	OFF																																																																										
0	1	0	1	1	OFF	ON																																																																										
0	1	0	0	1	OFF	ON																																																																										
0	1	0	1	0	ON	ON																																																																										
0	1	1	*	*	ON	ON																																																																										
(9)	OSC dividing ratio control WEATHER DIV_SW3	<p>□ Data to set the OSC dividing ratio at reception of AM/FM/WB</p> <table border="1" style="width: 100%; border-collapse: collapse; text-align: center;"> <thead> <tr> <th>WEATHER</th> <th>DIV_SW3</th> <th>Dividing ratio</th> </tr> </thead> <tbody> <tr><td>0</td><td>0</td><td>2-division</td></tr> <tr><td>0</td><td>1</td><td>3-division</td></tr> <tr><td>1</td><td>0</td><td>1-division</td></tr> <tr><td>1</td><td>1</td><td>1-division</td></tr> </tbody> </table>	WEATHER	DIV_SW3	Dividing ratio	0	0	2-division	0	1	3-division	1	0	1-division	1	1	1-division	AM/FM P0 to P15 OSC D1, OSC D2																																																														
WEATHER	DIV_SW3	Dividing ratio																																																																														
0	0	2-division																																																																														
0	1	3-division																																																																														
1	0	1-division																																																																														
1	1	1-division																																																																														
(10)	IC internal signal I/O port Control data	<p>Data to designate I/O of the I/O port "Data" =0: input port Select "0" normally. =1: output port Select "1" for IC test * Select "0" for cases other than IC test.</p>																																																																														
(11)	X-TAL OSC Fine adjustment data	<p>Data to detune the reference frequency X'tal=20.5MHz when beat has occurred Variable by about 100Hz per bit in eight steps of 0 to 7 bits X'tal to be loaded with the external capacity at the 3-bit (110) setting</p> <table border="1" style="margin-left: auto; margin-right: auto; border-collapse: collapse; text-align: center;"> <thead> <tr> <th colspan="2">X'tal OSC ADJ</th> </tr> </thead> <tbody> <tr><td>0 0 0</td><td>+390Hz</td></tr> <tr><td>1 0 0</td><td>+250Hz</td></tr> <tr><td>0 1 0</td><td>+110Hz</td></tr> <tr><td>1 1 0</td><td>X'tal (center value)</td></tr> <tr><td>0 0 1</td><td>-100Hz</td></tr> <tr><td>1 0 1</td><td>-190Hz</td></tr> <tr><td>0 1 1</td><td>-280Hz</td></tr> <tr><td>1 1 1</td><td>-350Hz</td></tr> </tbody> </table>	X'tal OSC ADJ		0 0 0	+390Hz	1 0 0	+250Hz	0 1 0	+110Hz	1 1 0	X'tal (center value)	0 0 1	-100Hz	1 0 1	-190Hz	0 1 1	-280Hz	1 1 1	-350Hz																																																												
X'tal OSC ADJ																																																																																
0 0 0	+390Hz																																																																															
1 0 0	+250Hz																																																																															
0 1 0	+110Hz																																																																															
1 1 0	X'tal (center value)																																																																															
0 0 1	-100Hz																																																																															
1 0 1	-190Hz																																																																															
0 1 1	-280Hz																																																																															
1 1 1	-350Hz																																																																															
(12)	AMSD speedup SDSPEED	<p>Data to speed up the SD rise time in the AM mode "SDSPEED"=0: NORMAL mode =1: speedup mode</p>																																																																														
(13)	DO pin Control data IL0,IL1	<p>□ Data to control the DO pin output</p> <table border="1" style="width: 100%; border-collapse: collapse; text-align: center;"> <thead> <tr> <th>IL1</th> <th>IL0</th> <th>IN</th> </tr> </thead> <tbody> <tr><td>0</td><td>0</td><td>Open</td></tr> <tr><td>0</td><td>1</td><td>SD pin state (PIN13)</td></tr> <tr><td>1</td><td>0</td><td>Pin I2 state (not used)</td></tr> <tr><td>1</td><td>1</td><td>Do not use</td></tr> </tbody> </table> <p>Open when I/O-1 and I/O-2 pins are designated as output ports. Note) Do not use with X'tal OSC STOP (DO does not change)</p>	IL1	IL0	IN	0	0	Open	0	1	SD pin state (PIN13)	1	0	Pin I2 state (not used)	1	1	Do not use																																																															
IL1	IL0	IN																																																																														
0	0	Open																																																																														
0	1	SD pin state (PIN13)																																																																														
1	0	Pin I2 state (not used)																																																																														
1	1	Do not use																																																																														
(14)	AM/FM-AGC ON Control data FMAGC_ON AMAGC_ON	<p>Data to make AGC of each of AM and FM effective</p> <table style="width: 100%; border: none;"> <tr> <td style="border: none;">"FMAGC_ON"=0: NORMAL mode</td> <td rowspan="2" style="border: none; vertical-align: middle;">} For FM</td> </tr> <tr> <td style="border: none;">=1: Forced ON mode</td> </tr> <tr> <td style="border: none;">"AMAGC_ON"=0: NORMAL mode</td> <td rowspan="2" style="border: none; vertical-align: middle;">} For AM</td> </tr> <tr> <td style="border: none;">=1: Forced ON mode</td> </tr> </table>	"FMAGC_ON"=0: NORMAL mode	} For FM	=1: Forced ON mode	"AMAGC_ON"=0: NORMAL mode	} For AM	=1: Forced ON mode																																																																								
"FMAGC_ON"=0: NORMAL mode	} For FM																																																																															
=1: Forced ON mode																																																																																
"AMAGC_ON"=0: NORMAL mode	} For AM																																																																															
=1: Forced ON mode																																																																																
(15)	IF count sensitivity deterioration control data CTC	<p>□ Decrease the input sensitivity with CTC=1. * Do not attempt change of bits during count (except for EVR).</p>																																																																														

Continued on next page.

LV25200M

Continued from preceding page.

No.	Control block/data	Description	Related data																																				
(16)	General-purpose counter Control data GT0, GT1 CTP	<p>□ Data to determine the general-purpose counter measurement time (frequency mode) and number of cycles (cycle mode).</p> <table border="1" style="width: 100%; border-collapse: collapse; margin-bottom: 10px;"> <thead> <tr> <th rowspan="3">GT1</th> <th rowspan="3">GT0</th> <th colspan="2">Frequency measurement</th> <th rowspan="3">Cycle measurement mode</th> </tr> <tr> <th rowspan="2">Measurement time</th> <th colspan="2">Wait time</th> </tr> <tr> <th>CTP=0</th> <th>CTP=1</th> </tr> </thead> <tbody> <tr> <td style="text-align: center;">0</td> <td style="text-align: center;">0</td> <td style="text-align: center;">4ms</td> <td style="text-align: center;">3 to 4ms</td> <td style="text-align: center;">1 to 2ms</td> <td style="text-align: center;">1 cycle</td> </tr> <tr> <td style="text-align: center;">0</td> <td style="text-align: center;">1</td> <td style="text-align: center;">8ms</td> <td style="text-align: center;">3 to 4ms</td> <td style="text-align: center;">1 to 2ms</td> <td style="text-align: center;">1 cycle</td> </tr> <tr> <td style="text-align: center;">1</td> <td style="text-align: center;">0</td> <td style="text-align: center;">32ms</td> <td style="text-align: center;">7 to 8ms</td> <td style="text-align: center;">1 to 2ms</td> <td style="text-align: center;">2 cycles</td> </tr> <tr> <td style="text-align: center;">1</td> <td style="text-align: center;">1</td> <td style="text-align: center;">64ms</td> <td style="text-align: center;">7 to 8ms</td> <td style="text-align: center;">1 to 2ms</td> <td style="text-align: center;">2 cycles</td> </tr> </tbody> </table> <p>□ CTP=0: General-purpose counter input stopped at counter reset (CTE=0) =1: General-purpose counter input not stopped and the wait time shortened at counter reset (CTE=0)</p> <p>Except that Immediately after setting of CTP=1, it is necessary to wait for counter start till the general-purpose counter input pin is biased.</p>	GT1	GT0	Frequency measurement		Cycle measurement mode	Measurement time	Wait time		CTP=0	CTP=1	0	0	4ms	3 to 4ms	1 to 2ms	1 cycle	0	1	8ms	3 to 4ms	1 to 2ms	1 cycle	1	0	32ms	7 to 8ms	1 to 2ms	2 cycles	1	1	64ms	7 to 8ms	1 to 2ms	2 cycles			
GT1	GT0	Frequency measurement			Cycle measurement mode																																		
		Measurement time				Wait time																																	
			CTP=0	CTP=1																																			
0	0	4ms	3 to 4ms	1 to 2ms	1 cycle																																		
0	1	8ms	3 to 4ms	1 to 2ms	1 cycle																																		
1	0	32ms	7 to 8ms	1 to 2ms	2 cycles																																		
1	1	64ms	7 to 8ms	1 to 2ms	2 cycles																																		
(17)	DO pin control data ULD DT0, DT1	<p>□ Data to determine the output of DO pin.</p> <table border="1" style="width: 100%; border-collapse: collapse; margin-bottom: 10px;"> <thead> <tr> <th>ULD</th> <th>DT1</th> <th>DT0</th> <th>DO pin</th> </tr> </thead> <tbody> <tr> <td style="text-align: center;">0</td> <td style="text-align: center;">0</td> <td style="text-align: center;">0</td> <td>Low when unlocked</td> </tr> <tr> <td style="text-align: center;">0</td> <td style="text-align: center;">0</td> <td style="text-align: center;">1</td> <td>Do not use</td> </tr> <tr> <td style="text-align: center;">0</td> <td style="text-align: center;">1</td> <td style="text-align: center;">0</td> <td>end-UC</td> </tr> <tr> <td style="text-align: center;">0</td> <td style="text-align: center;">1</td> <td style="text-align: center;">1</td> <td>IN (*1)</td> </tr> <tr> <td style="text-align: center;">1</td> <td style="text-align: center;">0</td> <td style="text-align: center;">0</td> <td>Open</td> </tr> <tr> <td style="text-align: center;">1</td> <td style="text-align: center;">0</td> <td style="text-align: center;">1</td> <td>Do not use</td> </tr> <tr> <td style="text-align: center;">1</td> <td style="text-align: center;">1</td> <td style="text-align: center;">0</td> <td>end-UC</td> </tr> <tr> <td style="text-align: center;">1</td> <td style="text-align: center;">1</td> <td style="text-align: center;">1</td> <td>IN (*1)</td> </tr> </tbody> </table> <p>end-UC: Count over of the general-purpose counter</p>	ULD	DT1	DT0	DO pin	0	0	0	Low when unlocked	0	0	1	Do not use	0	1	0	end-UC	0	1	1	IN (*1)	1	0	0	Open	1	0	1	Do not use	1	1	0	end-UC	1	1	1	IN (*1)	
ULD	DT1	DT0	DO pin																																				
0	0	0	Low when unlocked																																				
0	0	1	Do not use																																				
0	1	0	end-UC																																				
0	1	1	IN (*1)																																				
1	0	0	Open																																				
1	0	1	Do not use																																				
1	1	0	end-UC																																				
1	1	1	IN (*1)																																				
(18)	Unlock detection data UL0, UL1	<p>□ Data to select the phase error (ϕE) detection width in order to check PLL for locking. Phase error exceeding the ϕE detection width shown in the table below is determined to indicate unlock. At unlock, the detection pin (DO) becomes Low.</p> <table border="1" style="width: 100%; border-collapse: collapse; margin-bottom: 10px;"> <thead> <tr> <th>UL1</th> <th>UL0</th> <th>ϕE detection width</th> <th>Detection pin output</th> </tr> </thead> <tbody> <tr> <td style="text-align: center;">0</td> <td style="text-align: center;">0</td> <td style="text-align: center;">Stop</td> <td style="text-align: center;">Open</td> </tr> <tr> <td style="text-align: center;">0</td> <td style="text-align: center;">1</td> <td style="text-align: center;">0</td> <td style="text-align: center;">ϕE output directly</td> </tr> <tr> <td style="text-align: center;">1</td> <td style="text-align: center;">0</td> <td style="text-align: center;">$\pm 0.5\mu s$</td> <td style="text-align: center;">ϕE extended by 1 to 2ms</td> </tr> <tr> <td style="text-align: center;">1</td> <td style="text-align: center;">1</td> <td style="text-align: center;">$\pm 1\mu s$</td> <td style="text-align: center;">ϕE extended by 1 to 2ms</td> </tr> </tbody> </table>	UL1	UL0	ϕE detection width	Detection pin output	0	0	Stop	Open	0	1	0	ϕE output directly	1	0	$\pm 0.5\mu s$	ϕE extended by 1 to 2ms	1	1	$\pm 1\mu s$	ϕE extended by 1 to 2ms	ULD DT0, DT1																
UL1	UL0	ϕE detection width	Detection pin output																																				
0	0	Stop	Open																																				
0	1	0	ϕE output directly																																				
1	0	$\pm 0.5\mu s$	ϕE extended by 1 to 2ms																																				
1	1	$\pm 1\mu s$	ϕE extended by 1 to 2ms																																				
(19)	IF count operation control data CTS	<p>□ Data to select the general-purpose counter input pin (HCTR) in IC CTS=1: HSTR pin in IC selected 0: HCTR pin in IC pulled down</p>																																					
(20)	Sub-charge pump control data PDC0, PDC1	<p>□ Data to control the sub-charge pump</p> <table border="1" style="width: 100%; border-collapse: collapse; margin-bottom: 10px;"> <thead> <tr> <th>PDC1</th> <th>PDC0</th> <th>Sub-charge pump state</th> </tr> </thead> <tbody> <tr> <td style="text-align: center;">0</td> <td style="text-align: center;">*</td> <td style="text-align: center;">High impedance</td> </tr> <tr> <td style="text-align: center;">1</td> <td style="text-align: center;">0</td> <td style="text-align: center;">Charge pump operating (unlocked)</td> </tr> <tr> <td style="text-align: center;">1</td> <td style="text-align: center;">1</td> <td style="text-align: center;">Charge pump operating (normal)</td> </tr> </tbody> </table> <p style="text-align: right;">(*: don't care)</p> <p>* The sub-charge pump output is connected internally with the LPF FET gate. The sub-charge pump and the PD (main charge pump) pin are combined to form the fast lockup circuit.</p> <p>* Except that this may not be effective depending on the filter multiplier (lighter filter).</p>	PDC1	PDC0	Sub-charge pump state	0	*	High impedance	1	0	Charge pump operating (unlocked)	1	1	Charge pump operating (normal)	UL0, UL1, DLC																								
PDC1	PDC0	Sub-charge pump state																																					
0	*	High impedance																																					
1	0	Charge pump operating (unlocked)																																					
1	1	Charge pump operating (normal)																																					

Continued on next page.

LV25200M

Continued from preceding page.

No.	Control block/data	Description	Related data																																																												
(21)	Phase comparator control data DZ0, DZ1	<p>□ Data to control the dead band of phase comparator</p> <table border="1"> <thead> <tr> <th>DZ1</th> <th>DZ0</th> <th>Deadban mode</th> </tr> </thead> <tbody> <tr> <td>0</td> <td>0</td> <td>DZA</td> </tr> <tr> <td>0</td> <td>1</td> <td>DZB</td> </tr> <tr> <td>1</td> <td>0</td> <td>DZC</td> </tr> <tr> <td>1</td> <td>1</td> <td>DZD</td> </tr> </tbody> </table> <p>* DZA at power ON and power reset</p>	DZ1	DZ0	Deadban mode	0	0	DZA	0	1	DZB	1	0	DZC	1	1	DZD																																														
DZ1	DZ0	Deadban mode																																																													
0	0	DZA																																																													
0	1	DZB																																																													
1	0	DZC																																																													
1	1	DZD																																																													
(22)	Charge pump control data DLC	<p>□ Data to set the charge pump output to the low level (V_{SS} level) in a forced manner. DLC=1: Low level =0: Normal operation</p> <p>* When the VCO control voltage (V_{tune}) is deadlocked because VCO stops oscillation at 0V, this data sets the charge pump output to the low level and V_{tune} to V_{CC}, enabling escape from the deadlock state. Normal operation mode at power ON and power reset</p>																																																													
(23)	IC test data TEST0 TEST1 TEST2	<p>□ IC test data Set as follows: TEST0=0 TEST1=0 TEST2=0</p> <p>* All of test data is set to "0" at power ON and power reset.</p>																																																													
(24)	RF-DAC control D31-0 to D31-8	<p>□ Causes application of the control voltage to the RF tuning circuit (varactor). 9BIT</p>																																																													
(25)	Internal monitor changeover data D31-9	<p>□ Data to changeover the internal monitor. 1BIT</p>																																																													
(26)	ANT-DAC control D31-10 to D31-18	<p>□ Causes application of the control voltage to the ANT tuning circuit (varactor). 9BIT</p>																																																													
(27)	MSLOP Control changeover data D31-19	<p>□ Data to change over the FM MUTE curve inclination. 1BIT</p> <p>MSLOP</p> <table border="1"> <tr> <td>0</td> <td>Mute_D (steep inclination)</td> </tr> <tr> <td>1</td> <td>Mute_D (gentle inclination)</td> </tr> </table>	0	Mute_D (steep inclination)	1	Mute_D (gentle inclination)																																																									
0	Mute_D (steep inclination)																																																														
1	Mute_D (gentle inclination)																																																														
(28)	Band variable filter control data D31-20 to D31-25	<p>□ Narrow/wide band - (MIN/MAX) data to set the band variable filter Each 3bits for narrow and wide bands</p> <p>Band variable filter Narrow/wide band MIN/MAC control value</p> <table border="0"> <tr> <td colspan="3">Narrow LMT Cont</td> <td colspan="3">Wide LMT Cont</td> </tr> <tr> <td>D20</td> <td>D21</td> <td>D22</td> <td>D23</td> <td>D24</td> <td>D25</td> </tr> <tr> <td>0 0 0</td> <td colspan="2">Min (40k)</td> <td>0 0 0</td> <td colspan="2">Max (220k)</td> </tr> <tr> <td>1 0 0</td> <td></td> <td></td> <td>1 0 0</td> <td></td> <td></td> </tr> <tr> <td>0 1 0</td> <td></td> <td></td> <td>0 1 0</td> <td></td> <td></td> </tr> <tr> <td>•</td> <td></td> <td></td> <td>•</td> <td></td> <td></td> </tr> <tr> <td>•</td> <td></td> <td></td> <td>•</td> <td></td> <td></td> </tr> <tr> <td>1 0 1</td> <td></td> <td></td> <td>1 0 1</td> <td></td> <td></td> </tr> <tr> <td>0 1 1</td> <td></td> <td></td> <td>0 1 1</td> <td></td> <td></td> </tr> <tr> <td>1 1 1</td> <td colspan="2">Max (80k)</td> <td>1 1 1</td> <td colspan="2">Min (150k)</td> </tr> </table>	Narrow LMT Cont			Wide LMT Cont			D20	D21	D22	D23	D24	D25	0 0 0	Min (40k)		0 0 0	Max (220k)		1 0 0			1 0 0			0 1 0			0 1 0			•			•			•			•			1 0 1			1 0 1			0 1 1			0 1 1			1 1 1	Max (80k)		1 1 1	Min (150k)		
Narrow LMT Cont			Wide LMT Cont																																																												
D20	D21	D22	D23	D24	D25																																																										
0 0 0	Min (40k)		0 0 0	Max (220k)																																																											
1 0 0			1 0 0																																																												
0 1 0			0 1 0																																																												
•			•																																																												
•			•																																																												
1 0 1			1 0 1																																																												
0 1 1			0 1 1																																																												
1 1 1	Max (80k)		1 1 1	Min (150k)																																																											
(29)	Band variable filter mode setting D31-26 to D31-27	<p>□ Data to set the mode of band variable filter. 2BIT</p> <p>Filter-Fix_SW</p> <table border="1"> <thead> <tr> <th>D26</th> <th>D27</th> <th>Filter-Mode</th> </tr> </thead> <tbody> <tr> <td>0</td> <td>0</td> <td>Variable</td> </tr> <tr> <td>1</td> <td>0</td> <td>Narrow-Fix</td> </tr> <tr> <td>0</td> <td>1</td> <td>Wide-Fix</td> </tr> <tr> <td>1</td> <td>1</td> <td>Dont Care</td> </tr> </tbody> </table>	D26	D27	Filter-Mode	0	0	Variable	1	0	Narrow-Fix	0	1	Wide-Fix	1	1	Dont Care																																														
D26	D27	Filter-Mode																																																													
0	0	Variable																																																													
1	0	Narrow-Fix																																																													
0	1	Wide-Fix																																																													
1	1	Dont Care																																																													
(30)	DAC TEST select data D31-29	<p>□ Data to select the output circuit of internal DAC circuit</p>																																																													
(31)	S-meter shifter control D32-0 to D32-4	<p>□ Controls the output value of FM S-METER shifter circuit. 5BIT</p>																																																													
(32)	FM MUTE-ON-adj/ AM NC stop control D32-5 to D32-9	<p>□ FM: Controls FM MUTE-ON-adj characteristic. AM: Controls the sensitivity of AM NC stop. 5BIT</p>																																																													
(33)	FM MUTE-ATT/ AM NC Gate-Time control D32-10 to D32-15	<p>□ FM: Controls FM MUTE-ATT characteristic. AM: Controls the width of AM NC Gate-Time characteristic. 6BIT</p>																																																													

Continued on next page.

LV25200M

Continued from preceding page.

No.	Control block/data	Description	Related data								
(34)	Weak input MUTE changeover D31-16 to D31-18	▣ Changes over weak input MUTE. 3BIT									
(35)	AM/FM SD-adj NC-AGC threshold voltage setting data D31-19 to D32-23	▣ Controls SD characteristic of AM/FM. Sets the threshold voltage of NC-AGC. 5BIT									
(36)	FM IF-Gain /AM NC Gain control data D32-24 to D32-27	▣ Controls Gain of FM IF limiter AMP. Controls also Gain of IF limiter AMP in the AM mode similarly to the FM mode. 4BIT									
(37)	TUNER OFF setting data D32-28	▣ Data to set the mode to turn OFF the tuner. 1BIT Tuner OFF mode <table border="1" style="display: inline-table; vertical-align: middle;"> <tr><td>0</td><td>Normal operation</td></tr> <tr><td>1</td><td>Tuner-OFF</td></tr> </table>	0	Normal operation	1	Tuner-OFF					
0	Normal operation										
1	Tuner-OFF										
(38)	AM/FM WAGC setting data D33-0 to D33-3	▣ Data to set the AM/FM WAGC sensitivity. 4BIT									
(39)	AM/FM NAGC setting data D33-4 to D33-7	▣ Data to set the AM/FM NAGC sensitivity. 4BIT									
(40)	Keyed-AGC/ AM-IF-Gain setting data D33-8 to D33-11	▣ Controls FM Keyed-AGC sensitivity. Controls AM-IF-GAIN. 4BIT									
(41)	SD detection bandwidth setting/band variable filter start point setting data D33-12 to D33-15	▣ Used to set the SD detection bandwidth at FM-SEEK. Used to set the start point of band variable filter at FM reception. 4BIT									
(42)	Null Voltage setting data D33-16 to D33-20	▣ Controls the FM Null voltage. 5BIT									
(43)	QDP-ADJ setting data D33-21 to D33-24	▣ Controls the FM QDP voltage. 4BIT									
(44)	FM MUTE-ATT SW/AM S-meter shifter control D33-25 to D33-26	▣ FM: Controls FM MUTE-ATT-SW characteristic. AM: Controls S-meter shifter circuit output value. 2BIT Mute-ATT-SW/AM-Vsm-Shift <table border="1" style="display: inline-table; vertical-align: middle;"> <tr><td>0 0</td><td>Low (steep inclination)</td></tr> <tr><td>1 0</td><td></td></tr> <tr><td>0 1</td><td></td></tr> <tr><td>1 1</td><td>High (gentle inclination)</td></tr> </table>	0 0	Low (steep inclination)	1 0		0 1		1 1	High (gentle inclination)	
0 0	Low (steep inclination)										
1 0											
0 1											
1 1	High (gentle inclination)										
(45)	VREF2.7V adj control D33-27 to D33-28	▣ Sets the Vref2.7V output voltage to the target value. 2BIT Vref2.7V ADJ <table border="1" style="display: inline-table; vertical-align: middle;"> <tr><td>0 0</td><td>Low</td></tr> <tr><td>1 0</td><td>Typ</td></tr> <tr><td>0 1</td><td>Little High</td></tr> <tr><td>1 1</td><td>High</td></tr> </table>	0 0	Low	1 0	Typ	0 1	Little High	1 1	High	
0 0	Low										
1 0	Typ										
0 1	Little High										
1 1	High										
(46)	Separation control D34-0 to D34-5	▣ Controls separation of L/R output level in the FM stereo mode. 6BIT									
(47)	FM SNC/ AM-RF-AGC AMP Threshold value (gentle inclination side) setting data D34-6 to D34-10	▣ Sets FM SNC characteristic. Sets AM-RF-AGC AMP (gentle inclination side) threshold voltage. 5BIT									
(48)	FM/AM HCC setting data D34-11 to D34-15	▣ Sets HCC characteristic of FM and AM. 5BIT									
(49)	SNC inclination setting data D34-16 to D34-17	▣ Sets inclination of SNC voltage (sets the separation curve). 2BIT SNC inclination <table border="1" style="display: inline-table; vertical-align: middle;"> <tr><td>0 0</td><td></td></tr> <tr><td>1 0</td><td>↓</td></tr> <tr><td>0 1</td><td>↓</td></tr> <tr><td>1 1</td><td></td></tr> </table>	0 0		1 0	↓	0 1	↓	1 1		
0 0											
1 0	↓										
0 1	↓										
1 1											

Continued on next page.

LV25200M

Continued from preceding page.

No.	Control block/data	Description	Related data									
(50)	Pilot cancel control D34-18 to D34-19	<p>□ Data to control the pilot cancel degree.</p> <p>2BIT Pi-Can (Pilot Cancel Level Control)</p> <table border="1"> <tr><td>0 0</td><td>Center (AM-NC=OFF)</td></tr> <tr><td>1 0</td><td>Low (same as above)</td></tr> <tr><td>0 1</td><td>High (same as above)</td></tr> <tr><td>1 1</td><td>OFF (AM-NC=ON)</td></tr> </table>	0 0	Center (AM-NC=OFF)	1 0	Low (same as above)	0 1	High (same as above)	1 1	OFF (AM-NC=ON)		
0 0	Center (AM-NC=OFF)											
1 0	Low (same as above)											
0 1	High (same as above)											
1 1	OFF (AM-NC=ON)											
(51)	De-emphasis select data D34-20	<p>□ Data to select the De-Emphasis constant of L/R output.</p> <p>1BIT De-emphasis</p> <table border="1"> <tr><td>0</td><td>50μs</td></tr> <tr><td>1</td><td>75μs</td></tr> </table>	0	50μs	1	75μs						
0	50μs											
1	75μs											
(52)	Force NOMO setting data D34-21	<p>□ Data to force L/R output to the MONO mode.</p> <p>1BIT</p> <table border="1"> <tr><td>0</td><td>Normal</td></tr> <tr><td>1</td><td>Forced MONO</td></tr> </table>	0	Normal	1	Forced MONO						
0	Normal											
1	Forced MONO											
(53)	Noise-AGC Threshold voltage forced application data D34-23	<p>□ Data to change the sensitivity by applying the Noise-AGC Threshold voltage in a forced manner.</p> <p>1BIT Noise-AGC Threshold voltage forced application</p> <table border="1"> <tr><td>0</td><td>OFF (Normal)</td></tr> <tr><td>1</td><td>ON(control with SD-ADJ-DAC)</td></tr> </table>	0	OFF (Normal)	1	ON(control with SD-ADJ-DAC)						
0	OFF (Normal)											
1	ON(control with SD-ADJ-DAC)											
(54)	Noise sensitivity setting data D34-24 to D34-25	<p>□ Controls the noise detection sensitivity.</p> <p>2BIT Noise-Sens setting</p> <table border="1"> <tr><td>0 0</td><td>Easy to detect</td></tr> <tr><td>1 0</td><td>↓</td></tr> <tr><td>0 1</td><td>↓</td></tr> <tr><td>1 1</td><td>Difficult to detect</td></tr> </table>	0 0	Easy to detect	1 0	↓	0 1	↓	1 1	Difficult to detect		
0 0	Easy to detect											
1 0	↓											
0 1	↓											
1 1	Difficult to detect											
(55)	AC S-meter Load changeover data D34-26	<p>□ S-meter output (Vsm2_sub): Data to change over the output impedance (internal load resistance) of pin 40</p> <p>1BIT AC-S meter load changeover</p> <table border="1"> <tr><td>0</td><td>Hi (7kΩ)</td></tr> <tr><td>1</td><td>Low (3.5kΩ)</td></tr> </table>	0	Hi (7kΩ)	1	Low (3.5kΩ)						
0	Hi (7kΩ)											
1	Low (3.5kΩ)											
(56)	Noise-AGC limit setting data D34-27	<p>□ Data to changeover the AGC limiter of noise canceller.</p> <p>1BIT Noise-AGC</p> <table border="1"> <tr><td>0</td><td>No Limit (AGC easy to be effective)</td></tr> <tr><td>1</td><td>Limit (AGC difficult to be effective)</td></tr> </table>	0	No Limit (AGC easy to be effective)	1	Limit (AGC difficult to be effective)						
0	No Limit (AGC easy to be effective)											
1	Limit (AGC difficult to be effective)											
(57)	D34-28	<p>□ No function</p> <p>1BIT</p> <table border="1"> <tr><td>0</td><td>0 : Normal setting</td></tr> <tr><td>1</td><td></td></tr> </table>	0	0 : Normal setting	1							
0	0 : Normal setting											
1												
(58)	MPX VCO control data D35-0 to D35-5	<p>□ Data for control to the MPX-VCO block free-run oscillation frequency of 304kHz</p> <p>6BIT</p>										
(59)	VCO ON measurement bit D35-6	<p>□ MPX-VCO block free-run oscillation frequency During measurement: High</p> <p>1BIT</p>										
(60)	HCC SW changeover bit D35-6	<p>□ Data to change the HCC function AM/FM mode</p> <p>1BIT HCC SW</p> <table border="1"> <tr><td>1</td><td>FM</td></tr> <tr><td>0</td><td>AM</td></tr> </table>	1	FM	0	AM						
1	FM											
0	AM											
(61)	Filter-Wide fixed sensitivity/ AM-RF-AGC AMP Threshold value (steep inclination side) setting data D35-8 to D35-11	<p>□ Sets the Filter-Wide fixed sensitivity. Sets the AM-RF-AGC AMP (steep inclination side) threshold voltage.</p> <p>4BIT</p>										
(62)	Filter initial adjustment bit D35-12 to D35-24	<p>□ Data for various initial settings of the filter</p> <p>13BIT</p> <table border="1"> <tr> <td>D12-14</td> <td>Gain</td> <td>Gain adjustment</td> </tr> <tr> <td>D15-19</td> <td>CF</td> <td>CF adjustment</td> </tr> <tr> <td>D20-24</td> <td>BW/G</td> <td>BW/G adjustment</td> </tr> </table>	D12-14	Gain	Gain adjustment	D15-19	CF	CF adjustment	D20-24	BW/G	BW/G adjustment	
D12-14	Gain	Gain adjustment										
D15-19	CF	CF adjustment										
D20-24	BW/G	BW/G adjustment										

Continued on next page.

LV25200M

Continued from preceding page.

No.	Control block/data	Description	Related data								
(63)	MRC Sensitivity Setting data D35-25 to D35-26	□ Data for sensitivity setting of MRC 2BIT MRC sensitivity <div style="display: inline-block; border: 1px solid black; padding: 2px;"> <table style="border-collapse: collapse;"> <tr><td style="padding: 2px 5px;">0 0</td><td style="padding: 2px 5px;">Low</td></tr> <tr><td style="padding: 2px 5px;">1 0</td><td style="padding: 2px 5px;">↓</td></tr> <tr><td style="padding: 2px 5px;">0 1</td><td style="padding: 2px 5px;">↓</td></tr> <tr><td style="padding: 2px 5px;">1 1</td><td style="padding: 2px 5px;">High</td></tr> </table> </div>	0 0	Low	1 0	↓	0 1	↓	1 1	High	
0 0	Low										
1 0	↓										
0 1	↓										
1 1	High										
(64)	MRC Time constant setting data D35-27 to D35-28	□ MRC time constant (Attack/Release Time) setting data 2BIT MRC time constant (Attack: Release Time) <div style="display: inline-block; border: 1px solid black; padding: 2px;"> <table style="border-collapse: collapse;"> <tr><td style="padding: 2px 5px;">0 0</td><td style="padding: 2px 5px;">Short</td></tr> <tr><td style="padding: 2px 5px;">1 0</td><td></td></tr> <tr><td style="padding: 2px 5px;">0 1</td><td></td></tr> <tr><td style="padding: 2px 5px;">1 1</td><td style="padding: 2px 5px;">Long</td></tr> </table> </div>	0 0	Short	1 0		0 1		1 1	Long	
0 0	Short										
1 0											
0 1											
1 1	Long										
(65)	D31-29 to D31-31 D32-29 to D32-31 D33-29 to D33-31 D34-29 to D34-31	□ Sub-Code Address Each 3 bits									

DO Output Data (Serial Data Output) Composition

[3] OUT

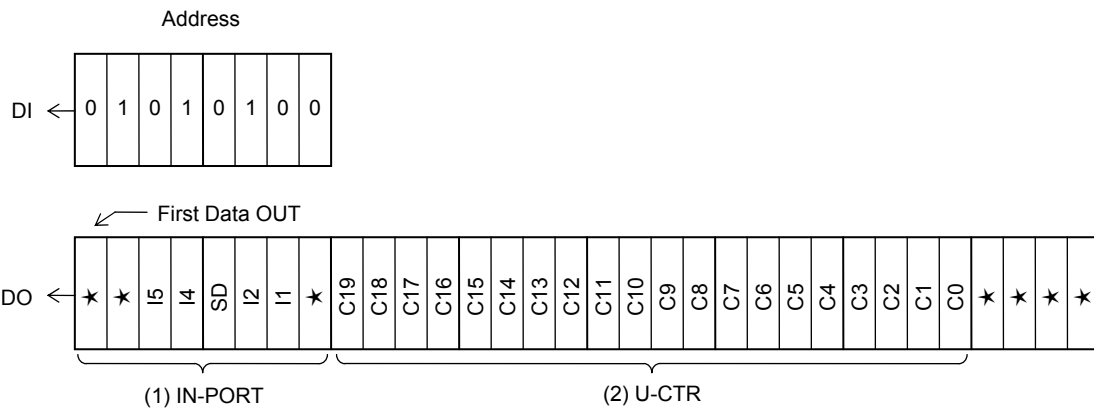

No.	Control block/data	Description	Related data
(1)	I/O port data I5 to I1	□ I/O port; Data latching the state of pin 14 and other pins become I1 to I5. Latched when the data output mode becomes effective. Pin state=Hi: 1 =Low: 0 Currently, only pin 14 (SD state)	TEST-BIT (I/O-PORT)
(2)	General-purpose counter binary data C19 to C0	□ Data latching the content of general-purpose counter (20-bit binary counter) becomes C19 to C0. C19 ← MSB of binary counter C0 ← LSB of binary counter	CTS0 CTS1 CTE

Programmable Divider Composition

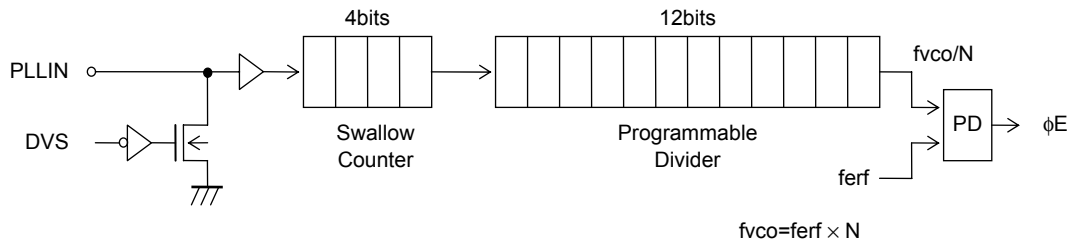

DVS	Set number of divisions (N)	Input frequency range (f [MHz])	PULL-IN pin in IC
1	272 to 65535	$120 \leq f \leq 270$	Selected
0	-	-	Stopped

* The input sensitivity is not shown here because the IC inside is closed.

Composition of The General-Purpose Counter

The general-purpose counter consists of 20-bit binary counters. The count result can be read from MSB through the DO pin.

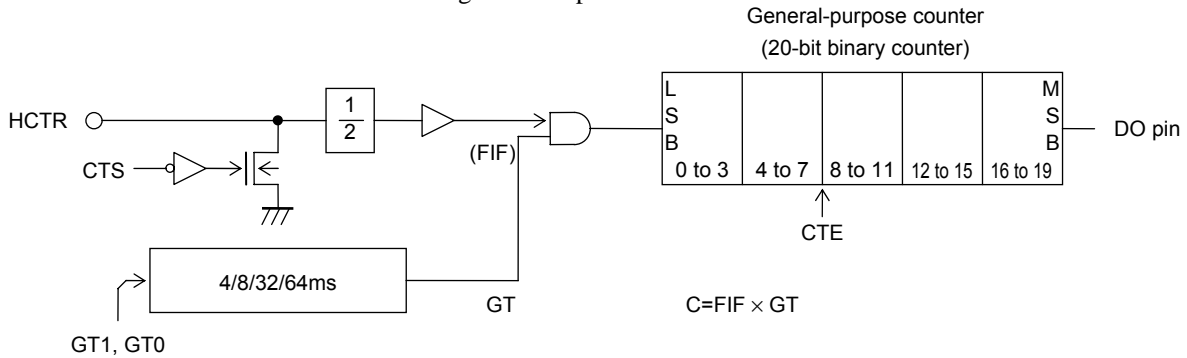

On the basis of GT0 and GT1 data, the measurement time for frequency measurement using the general-purpose counter can be selected from four types: 4,8,32,64 ms. By determining how many pulses are entered in the general-purpose counter within one of these periods, the frequency of signal entered in HCTR in IC can be determined.

CTP data: Data to determine the general-purpose counter input pin (HCTR) state at reset of this counter (CTE=0)

CTP = 0: General-purpose counter input pin turned OFF (pulled down)

= 1: General-purpose counter input pin not pulled down, but the wait time reduced to 1- 2 ms.

When setting CTP=1, it must be set first not later than 4 ms before count start (CTE=1).

When the counter is not to be used, set CTP=0.

GT1	GT0	Frequency measurement mode		
		Measurement time	Wait time	
			CTP=0	CTP=1
0	0	4ms	3 to 4ms	1 to 2ms
0	1	8ms	7 to 8ms	
1	0	32ms		
1	1	64ms		

IF Counter Operation

Before count start with the general-purpose counter, set CTE=0 to reset the counter beforehand.

The general-purpose counter starts counting by setting the serial data to CTE=1.

Then, the count result of the counter must be read out while CTE=1.

(With CTE=0, the general-purpose counter is reset.)

The signal entered in the HCTR pin in IC is divided into one half internally, and transmitted to the general-purpose counter.

Accordingly, the count result of general-purpose counter is the one-half value of the actual frequency entered in the HCTR pin in IC.

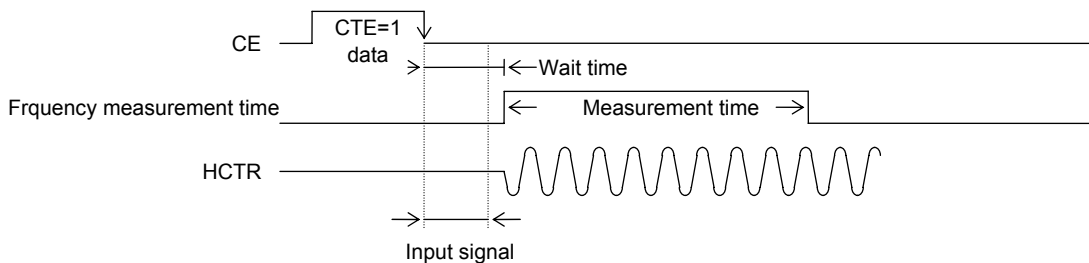

For the integrating counter

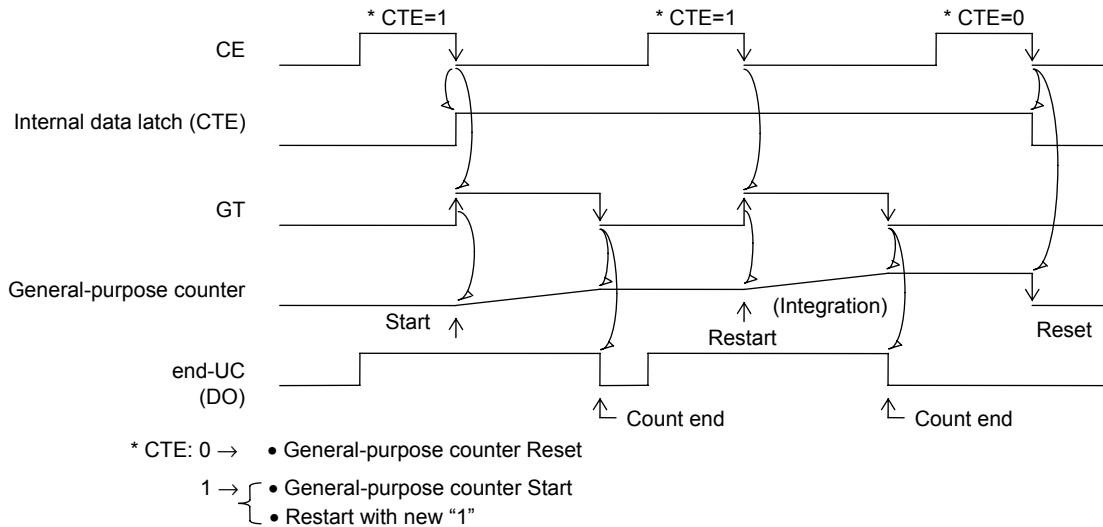

During integrating counting, the counts are accumulated in the general-purpose counter.

Take care not to allow overflow of the counter.

Count value: 0_H to $FFFF_H$ (1,048,575)

When the serial data (IN1) is re-transmitted while keeping CTE=1, the general-purpose counter restarts measurement and the integrating count results are added.

Phase Comparator/Charge Pump

(1) Phase comparator/charge pump operation

In the PLL circuit block shown in Fig. 1, the phase comparator compares the phase difference of the reference frequency(f_r) and comparative frequency (f_p) and outputs the phase difference components from the charge pump.

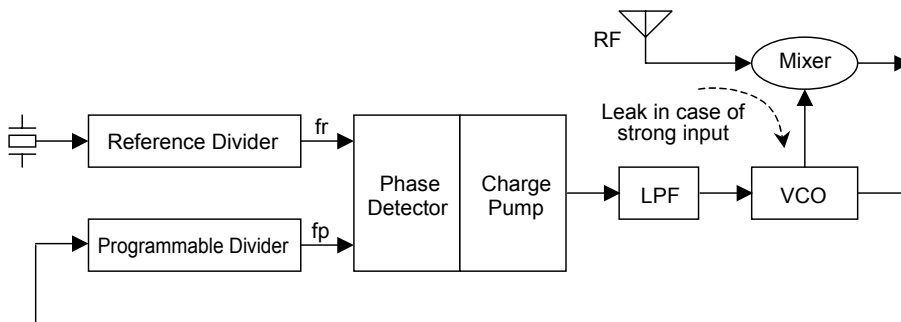

Fig. 1 PLL circuit block

LV25200M

Output characteristics of the phase comparator/charge pump are shown in Fig. 2.

The phase comparator outputs the output $V\phi$ that is proportional to the phase difference ϕ between f_r and f_p . By changing the setting of phase comparator dead zone mode, characteristics of phase comparator can be changed. Namely, the modes (DZA, DZB) to turn ON both P-CH and N-CH transistors of charge pump in case of extremely small phase difference and the mode (DZD) not to output the phase difference output in case of extremely small phase difference can be set.

Fig. 2 Phase comparator/charge pump characteristics

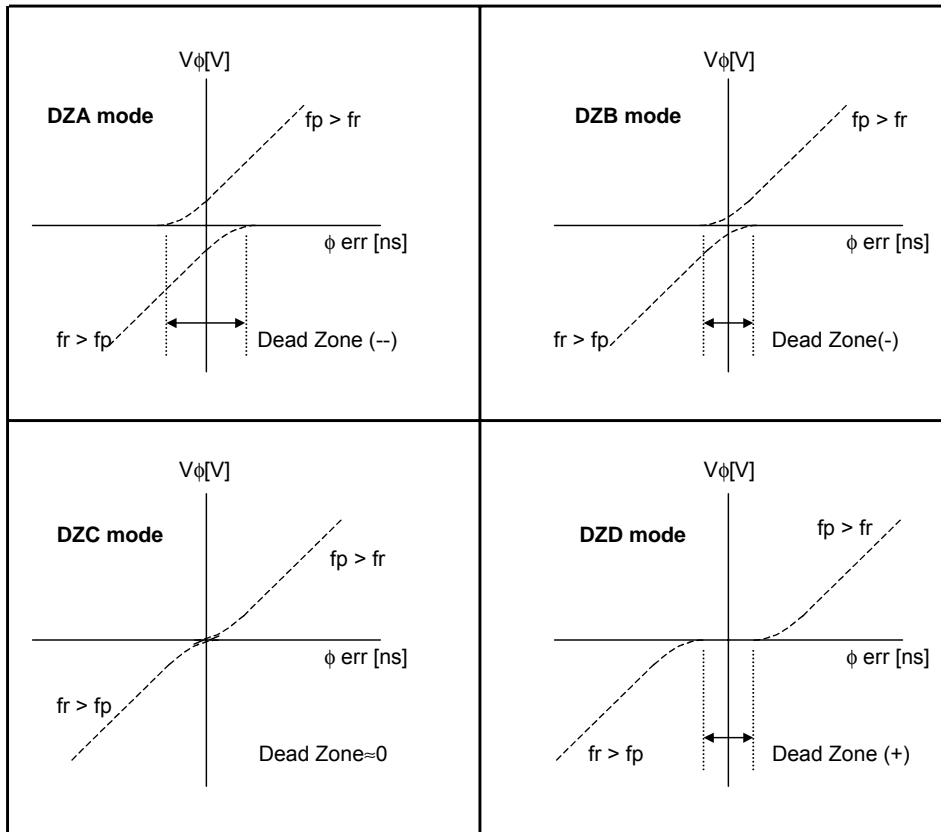

(2) Characteristics of the Dead Zone mode

The table below outlines characteristics in each dead zone mode.

Set data		Dead zone mode	Charge pump at phase difference 0 (Pch/Nch)	Dead zone width (Reference data)	Remarks
DZ1	DZ0				
0	0	DZA	ON/ON	-- (-15[ns])	
0	1	DZB	ON/ON	- (-8[ns])	
1	0	DZC	ON or OFF	≈0 (0[ns])	Do not use
1	1	DZD	OFF/OFF	+ (+8[ns])	

(3) Guideline and cautions for selecting the Dead Zone mode

Features of each Dead Zone mode and criteria for selection are described below:

1) DZA mode

In the DZA mode, the correction signal is output from the charge pump even when the phase difference agrees between the reference frequency (fr) and comparative frequency (fp), which is advantageous in obtaining the high S/N ratio with ease. On the other hand, the side band of reference frequency component may occur, readily causing beats in case of strong input. This is a phenomenon occurring because the PLL loop reacts sensitively due to leak components through the mixer, modulating VCO. Occurrence of side band of reference frequency component in the local oscillator also causes leakage of reference components to IF, which tends to worsen the interference characteristics.

2) DZB mode

The DZB mode is characterized by the reduced voltage of correction signal from the DZA mode though, similarly to the case of the DZA mode, the charge pump outputs the correction signal even when the phase difference agrees between the reference frequency (fr) and comparative frequency (fp). This mode features in easier achievement of high S/N ratio than DZC/DZD and improved beat and interference resistances.

3) DZC mode

In the DZC mode, the correction signal is output from the charge pump according to the phase difference between the reference frequency (fr) and comparative frequency (fp). Extremely small noise may occur when the phase difference is around 0 [ns]. Do not use this mode at low temperature (-30°C or less) because the S/N ratio may be deteriorated.

4) DZD mode

In the DZD mode, the correction signal is output from the charge pump according to the phase difference between the reference frequency (fr) and comparative frequency (fp). The correction signal is not output when the phase difference is \pm several [ns]. Accordingly, the S/N ratio becomes lower than other dead-zone modes, but beat and interference resistances can be improved.

- SANYO Semiconductor Co.,Ltd. assumes no responsibility for equipment failures that result from using products at values that exceed, even momentarily, rated values (such as maximum ratings, operating condition ranges, or other parameters) listed in products specifications of any and all SANYO Semiconductor Co.,Ltd. products described or contained herein.
- SANYO Semiconductor Co.,Ltd. strives to supply high-quality high-reliability products, however, any and all semiconductor products fail or malfunction with some probability. It is possible that these probabilistic failures or malfunction could give rise to accidents or events that could endanger human lives, trouble that could give rise to smoke or fire, or accidents that could cause damage to other property. When designing equipment, adopt safety measures so that these kinds of accidents or events cannot occur. Such measures include but are not limited to protective circuits and error prevention circuits for safe design, redundant design, and structural design.
- In the event that any or all SANYO Semiconductor Co.,Ltd. products described or contained herein are controlled under any of applicable local export control laws and regulations, such products may require the export license from the authorities concerned in accordance with the above law.
- No part of this publication may be reproduced or transmitted in any form or by any means, electronic or mechanical, including photocopying and recording, or any information storage or retrieval system, or otherwise, without the prior written consent of SANYO Semiconductor Co.,Ltd.
- Any and all information described or contained herein are subject to change without notice due to product/technology improvement, etc. When designing equipment, refer to the "Delivery Specification" for the SANYO Semiconductor Co.,Ltd. product that you intend to use.
- Information (including circuit diagrams and circuit parameters) herein is for example only; it is not guaranteed for volume production.
- Upon using the technical information or products described herein, neither warranty nor license shall be granted with regard to intellectual property rights or any other rights of SANYO Semiconductor Co.,Ltd. or any third party. SANYO Semiconductor Co.,Ltd. shall not be liable for any claim or suits with regard to a third party's intellectual property rights which has resulted from the use of the technical information and products mentioned above.

This catalog provides information as of December, 2007. Specifications and information herein are subject to change without notice.