

IN74HC123A

Dual Retriggerable Monostable Multivibrator

The IN74HC123A is identical in pinout to the LS/ALS123. The device inputs are compatible with standard CMOS outputs; with pullup resistors, they are compatible with LS/ALSTTL outputs.

There are two trigger inputs, \overline{A} INPUT (negative edge) and B INPUT (positive edge). These inputs are valid for rising/falling signals.

The device may also be triggered by using the CLR input (positive-edge) because of the Schmitt-trigger input; after triggering the output maintains the MONOSTABLE state for the time period determined by the external resistor R_X and capacitor C_X . Taking CLR low breaks this MONOSTABLE STATE. If the next trigger pulse occurs during the MONOSTABLE period it makes the MONOSTABLE period longer.

- Outputs Directly Interface to CMOS, NMOS, and TTL
- Operating Voltage Range: 3.0 to 6.0 V
- Low Input Current: 1.0 μ A
- High Noise Immunity Characteristic of CMOS Devices

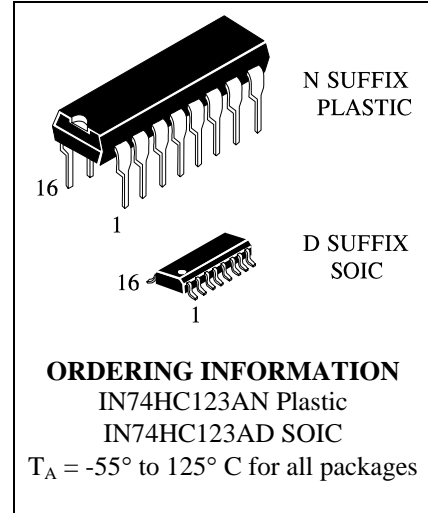

LOGIC DIAGRAM

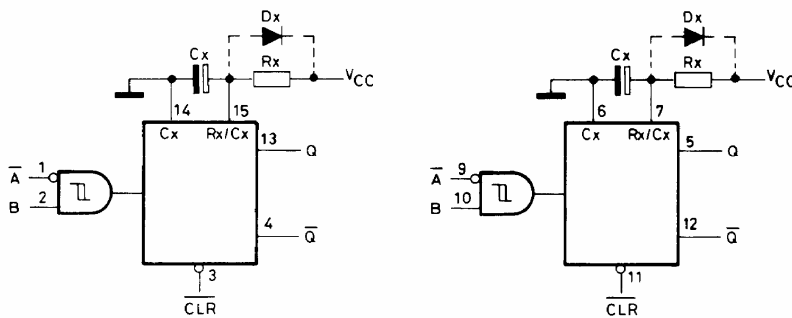

PIN 16 = V_{CC}
PIN 8 = GND

Note

- (1) C_X , R_X , D_X are external components.
- (2) D_X is a clamping diode.

The external capacitor is charged to V_{CC} in the stand-by state, i.e. no trigger. When the supply voltage is turned off C_X is discharged mainly through an internal parasitic diode. If C_X is sufficiently large and V_{CC} decreases rapidly, there will be some possibility of damaging the I.C. with a surge current or latch-up. If the voltage supply filter capacitor is large enough and V_{CC} decrease slowly, the surge current is automatically limited and damage the I.C. is avoided. The maximum forward current of the parasitic diode is approximately 20 mA.

PIN ASSIGNMENT

$\overline{1A}$	1	16	V_{CC}
1B	2	15	1REXT/CEX'
$\overline{1CLR}$	3	14	1CEXT
$\overline{1Q}$	4	13	1Q
2Q	5	12	$\overline{2Q}$
2CEXT	6	11	$\overline{2CLR}$
2REXT/CEXT	7	10	2B
GND	8	9	$\overline{2A}$

FUNCTION TABLE

Inputs			Outputs		Note
\overline{A}	B	\overline{CLR}	Q	\overline{Q}	
	H	H			Output Enable
X	L	H	L*	H*	Inhibit
H	X	H	L*	H*	Inhibit
L		H			Output Enable
L	H				Output Enable
X	X	L	L	H	Inhibit

X = don't care

* - except for monostable period

MAXIMUM RATINGS*

Symbol	Parameter	Value	Unit
V_{CC}	DC Supply Voltage (Referenced to GND)	-0.5 to +7.0	V
V_{IN}	DC Input Voltage (Referenced to GND)	-1.5 to $V_{CC} + 1.5$	V
V_{OUT}	DC Output Voltage (Referenced to GND)	-0.5 to $V_{CC} + 0.5$	V
I_{IN}	DC Input Current, per Pin A, B, \overline{CLR} C_X, R_X	± 20 ± 30	mA
I_{OUT}	DC Output Current, per Pin	± 25	mA
I_{CC}	DC Supply Current, V_{CC} and GND Pins	± 50	mA
P_D	Power Dissipation in Still Air, Plastic DIP+ SOIC Package+	750 500	mW
T_{stg}	Storage Temperature	-65 to +150	$^{\circ}C$
T_L	Lead Temperature, 1 mm from Case for 10 Seconds (Plastic DIP or SOIC Package)	260	$^{\circ}C$

*Maximum Ratings are those values beyond which damage to the device may occur. Functional operation should be restricted to the Recommended Operating Conditions.

+Derating - Plastic DIP: - 10 mW/ $^{\circ}C$ from 65 $^{\circ}$ to 125 $^{\circ}C$

SOIC Package: - 7 mW/ $^{\circ}C$ from 65 $^{\circ}$ to 125 $^{\circ}C$

RECOMMENDED OPERATING CONDITIONS

Symbol	Parameter	Min	Max	Unit	
V_{CC}	DC Supply Voltage (Referenced to GND)	3.0 **	6.0	V	
V_{IN}, V_{OUT}	DC Input Voltage, Output Voltage (Referenced to GND)	0	V_{CC}	V	
T_A	Operating Temperature, All Package Types	-55	+125	$^{\circ}C$	
t_r, t_f	Input Rise and Fall Time - \overline{CLR} (Figure 2)	$V_{CC} = 2.0$ V	0	1000	ns
		$V_{CC} = 4.5$ V	0	500	
		$V_{CC} = 6.0$ V	0	400	
	A or B	-	No Limit		
R_X	External Timing Resistor	$V_{CC} < 4.5$ V	10	1000	k Ω
		$V_{CC} \geq 4.5$ V	2.0	1000	
C_X	External Timing Capacitor	0	No Limit	μF	

** The In74HC123 will function at 2.0 V but for optimum pulse width stability, V_{CC} should be above 3.0 V.

This device contains protection circuitry to guard against damage due to high static voltages or electric fields. However, precautions must be taken to avoid applications of any voltage higher than maximum rated voltages to this high-impedance circuit. For proper operation, V_{IN} and V_{OUT} should be constrained to the range $GND \leq (V_{IN} \text{ or } V_{OUT}) \leq V_{CC}$.

Unused inputs must always be tied to an appropriate logic voltage level (e.g., either GND or V_{CC}). Unused outputs must be left open.

DC ELECTRICAL CHARACTERISTICS (Voltages Referenced to GND)

Symbol	Parameter	Test Conditions	V _{CC} V	Guaranteed Limit			Unit
				25 °C to -55°C	≤85 °C	≤125 °C	
V _{IH}	Minimum High-Level Input Voltage	V _{OUT} =0.1 V or V _{CC} -0.1 V I _{OUT} ≤ 20 μA	2.0	1.5	1.5	1.5	V
			4.5	3.15	3.15	3.15	
			6.0	4.2	4.2	4.2	
V _{IL}	Maximum Low - Level Input Voltage	V _{OUT} =0.1 V or V _{CC} -0.1 V I _{OUT} ≤ 20 μA	2.0	0.5	0.5	0.5	V
			4.5	1.35	1.35	1.35	
			6.0	1.8	1.8	1.8	
V _{OH}	Minimum High-Level Output Voltage	V _{IN} =V _{IH} or V _{IL} I _{OUT} ≤ 20 μA	2.0	1.9	1.9	1.9	V
			4.5	4.4	4.4	4.4	
		6.0	5.9	5.9	5.9		
		V _{IN} =V _{IH} or V _{IL} I _{OUT} ≤ 4.0 mA I _{OUT} ≤ 5.2 mA	4.5	3.98	3.84	3.7	
6.0	5.48	5.34	5.2				
V _{OL}	Maximum Low-Level Output Voltage	V _{IN} =V _{IH} or V _{IL} I _{OUT} ≤ 20 μA	2.0	0.1	0.1	0.1	V
			4.5	0.1	0.1	0.1	
		6.0	0.1	0.1	0.1		
		V _{IN} =V _{IH} or V _{IL} I _{OUT} ≤ 4.0 mA I _{OUT} ≤ 5.2 mA	4.5	0.26	0.33	0.4	
6.0	0.26	0.33	0.4				
I _{IN}	Maximum Input Leakage Current (A, B, CLR)	V _{IN} =V _{CC} or GND	6.0	±0.1	±1.0	±1.0	μA
I _{IN}	Maximum Input Leakage Current (R _X , C _X)	V _{IN} =V _{CC} or GND	6.0	±50	±500	±500	nA
I _{CC}	Maximum Quiescent Supply Current (per Package) Standby State	V _{IN} =V _{CC} or GND Q1 and Q2 = Low I _{OUT} =0μA	6.0	130	220	350	μA
I _{CC}	Maximum Supply Current (per Package) Active State	V _{IN} =V _{CC} or GND Q1 and Q2 = High I _{OUT} =0μA Pins 15 and 7 = 0.5 V _{CC}	6.0	25°C	-45°C to 85°C	-55°C to 125°C	μA
				400	600	800	

AC ELECTRICAL CHARACTERISTICS ($C_L=50\text{pF}$, Input $t_r=t_f=6.0\text{ ns}$)

Symbol	Parameter	V_{CC} V	Guaranteed Limit			Unit
			25 °C to -55°C	≤85 °C	≤125 °C	
t_{PLH}, t_{PHL}	Maximum Propagation Delay, Input \overline{A} or B to Q or \overline{Q} (Figures 1 and 3)	2.0	255	320	385	ns
		4.5	50	65	75	
		6.0	45	55	65	
t_{PLH}, t_{PHL}	Maximum Propagation Delay, \overline{CLR} to Q or \overline{Q} (Figures 2 and 3)	2.0	215	270	325	ns
		4.5	45	55	65	
		6.0	35	45	55	
t_{TLH}, t_{THL}	Maximum Output Transition Time, Any Output (Figures 2 and 3)	2.0	75	95	110	ns
		4.5	16	20	22	
		6.0	14	17	20	
C_{IN}	Maximum Input Capacitance $\overline{A}, B, \overline{CLR}$ C_X, R_X	-	10	10	10	pF
			25	25	25	

C_{PD}	Power Dissipation Capacitance (Per Multivibrator)	Typical @25°C, $V_{CC}=5.0\text{ V}$			pF
	Used to determine the no-load dynamic power consumption: $P_D=C_{PD}V_{CC}^2f+I_{CC}V_{CC}$	150			

TIMING REQUIREMENTS ($C_L=50\text{pF}$, Input $t_r=t_f=6.0\text{ ns}$)

Symbol	Parameter	V_{CC} V	Guaranteed Limit			Unit
			25 °C to -55°C	≤85°C	≤125°C	
t_{rec}	Minimum Recovery Time, Inactive to A or B (Figure 2)	2.0	0	0	0	ns
		4.5	0	0	0	
		6.0	0	0	0	
t_w	Minimum Pulse Width, Input A or B (Figure 1)	2.0	100	125	150	ns
		4.5	20	25	30	
		6.0	17	20	25	
t_w	Minimum Pulse Width, \overline{CLR} (Figure 2)	2.0	100	125	150	ns
		4.5	20	25	30	
		6.0	17	20	25	
t_r, t_f	Maximum Input Rise and Fall Times, \overline{CLR} (Figure 2)	2.0	1000	1000	1000	ns
		4.5	500	500	500	
		6.0	400	400	400	
	A or B (Figure 2)	2.0	No Limit			
		4.5				
6.0						

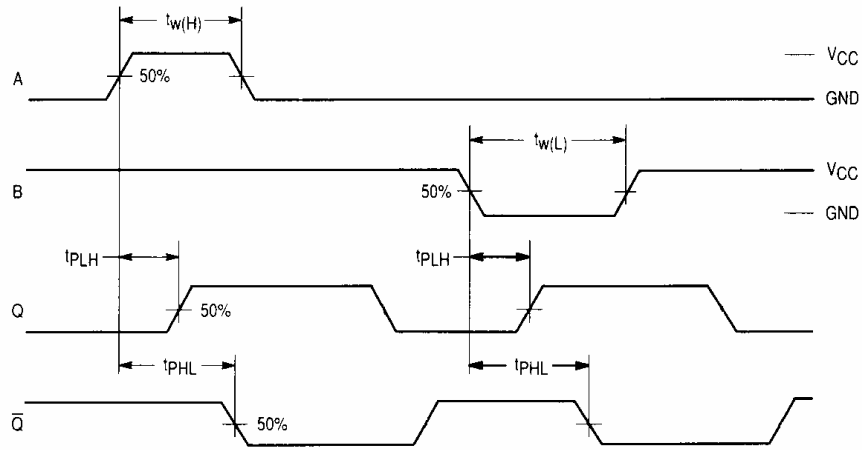

Figure 1. Switching Waveforms

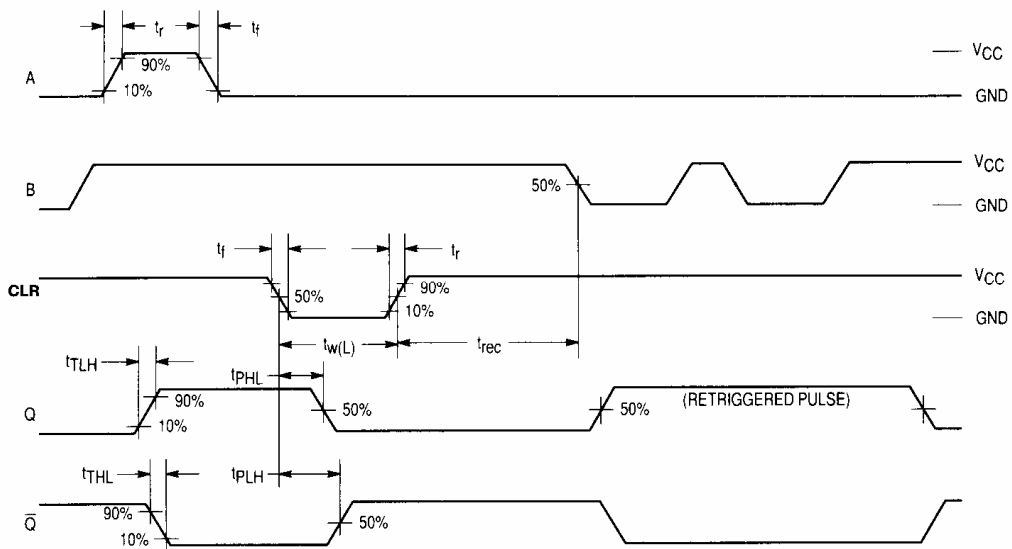
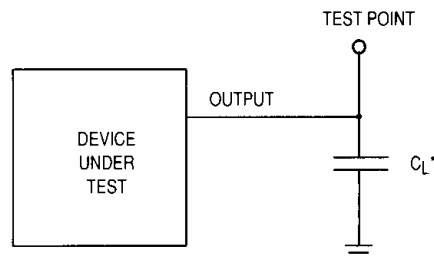

Figure 2. Switching Waveforms



*Includes all probe and jig capacitance

Figure 3. Test Circuit

TIMING DIAGRAM

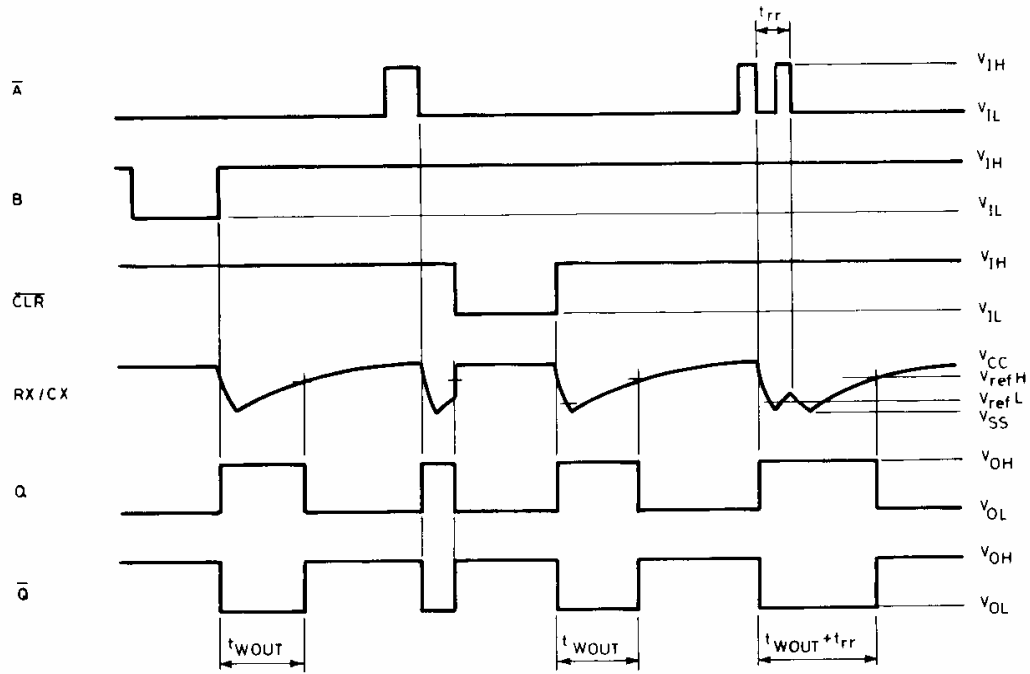

EXPANDED LOGIC DIAGRAM

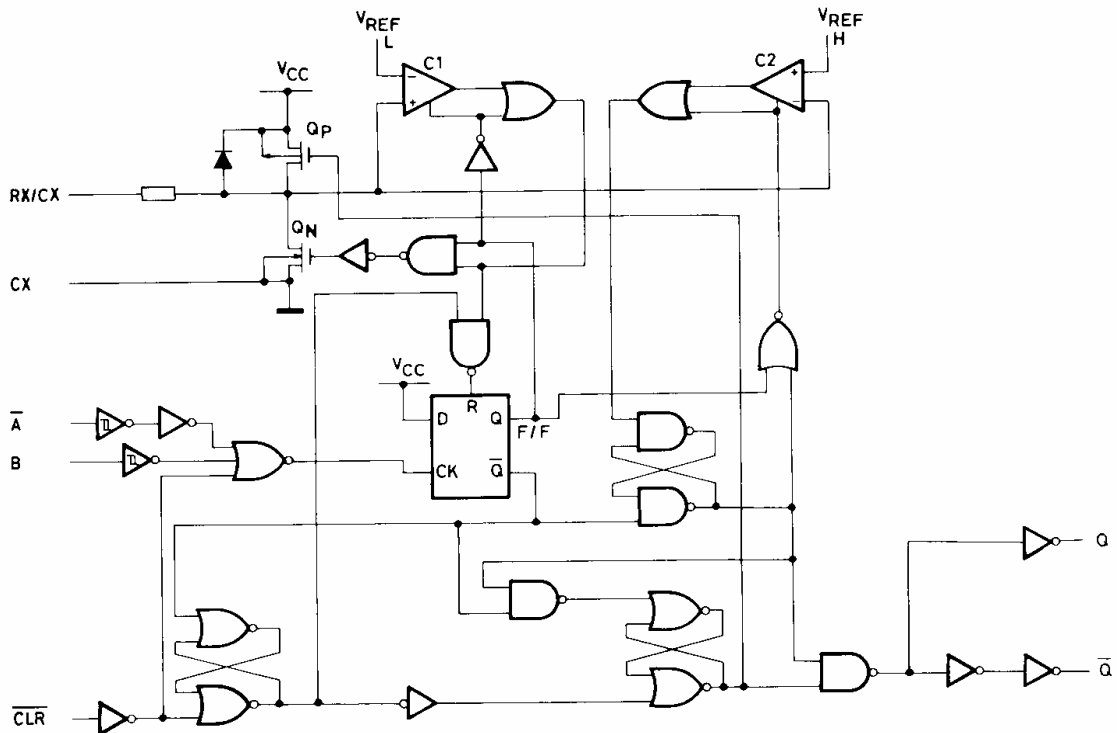

**N SUFFIX PLASTIC DIP
(MS - 001BB)**

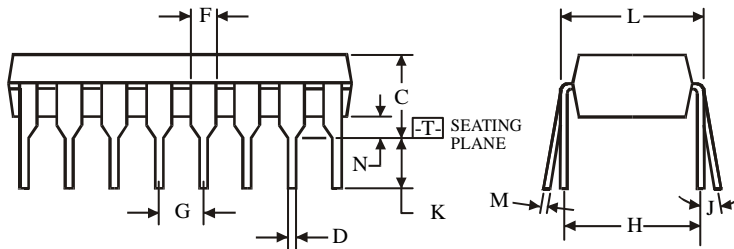
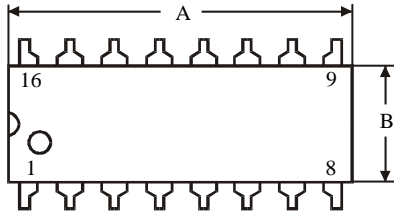
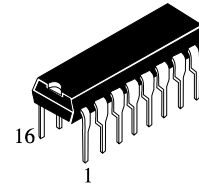

$\oplus 0.25 (0.010) \text{ (M) T}$

NOTES:

- Dimensions "A", "B" do not include mold flash or protrusions.
Maximum mold flash or protrusions 0.25 mm (0.010) per side.

Symbol	Dimension, mm	
	MIN	MAX
A	18.67	19.69
B	6.1	7.11
C		5.33
D	0.36	0.56
F	1.14	1.78
G	2.54	
H	7.62	
J	0°	10°
K	2.92	3.81
L	7.62	8.26
M	0.2	0.36
N	0.38	

**D SUFFIX SOIC
(MS - 012AC)**

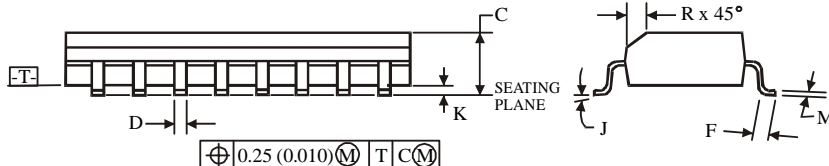
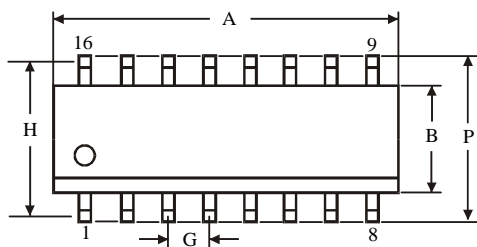
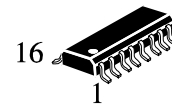

$\oplus 0.25 (0.010) \text{ (M) T C (M)}$

NOTES:

- Dimensions A and B do not include mold flash or protrusion.
- Maximum mold flash or protrusion 0.15 mm (0.006) per side for A; for B - 0.25 mm (0.010) per side.

Symbol	Dimension, mm	
	MIN	MAX
A	9.8	10
B	3.8	4
C	1.35	1.75
D	0.33	0.51
F	0.4	1.27
G	1.27	
H	5.72	
J	0°	8°
K	0.1	0.25
M	0.19	0.25
P	5.8	6.2
R	0.25	0.5