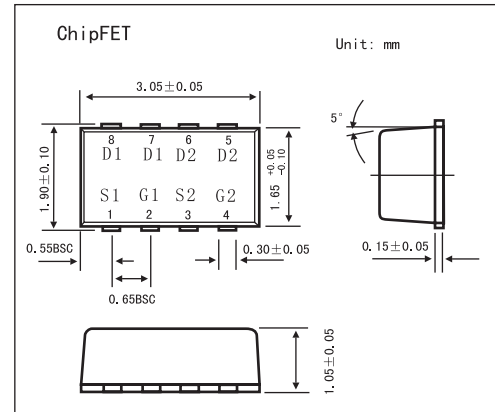
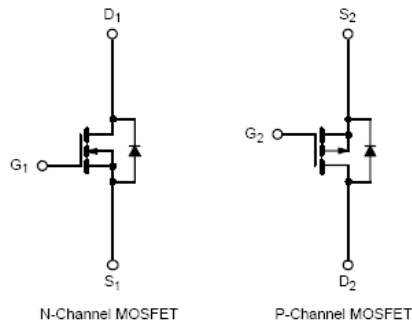

Complementary 30-V (D-S) MOSFET

KI5504DC

■ PIN Configuration

■ Absolute Maximum Ratings $T_A = 25^\circ\text{C}$

Parameter	Symbol	N-Channel		P-Channel		Unit	
		5 secs	Steady State	5 secs	Steady State		
Drain-Source Voltage	V_{DS}	30		-30		V	
Gate-Source Voltage	V_{GS}	± 20				V	
Continuous Drain Current ($T_J = 150^\circ\text{C}$)* $T_A = 25^\circ\text{C}$	I_D	± 3.9	± 2.9	± 2.8	± 2.1	A	
		± 2.8	± 2.1	± 2.0	± 1.5	A	
$T_A = 85^\circ\text{C}$							
Pulsed Drain Current	I_{DM}	± 10				A	
Continuous Source Current (Diode Conduction)*	I_S	1.8	0.9	-1.8	-0.9	A	
Maximum Power Dissipation*	P_D	$T_A = 25^\circ\text{C}$	2.1	1.1	2.1	1.1	W
		$T_A = 85^\circ\text{C}$	1.1	0.6	1.1	0.6	W
Operating Junction and Storage Temperature Range	T_J, T_{stg}	-55 to 150				$^\circ\text{C}$	

*Surface Mounted on 1" X 1" FR4 Board.

■ Thermal Resistance Ratings

Parameter		Symbol	Typ	Max	Unit
Maximum Junction-to-Ambient*	$t \leq 5 \text{ sec}$	R_{thJA}	50	60	$^\circ\text{C/W}$
	Steady State		90	110	
Maximum Junction-to-Case (Drain)	Steady State	R_{thJF}	30	40	

*Surface Mounted on 1" X 1" FR4 Board.

KI5504DC

■ Electrical Characteristics $T_J = 25^\circ\text{C}$

Parameter	Symbol	Testconditions	Min	Typ	Max	Unit	
Gate Threshold Voltage	$V_{GS(th)}$	$V_{DS} = V_{GS}, I_D = 250 \mu\text{A}$	N-Ch	0.1			V
		$V_{DS} = V_{GS}, I_D = -250 \mu\text{A}$	P-Ch	-1.0			
Gate Body Leakage	I_{GSS}	$V_{DS} = 0\text{V}, V_{GS} = \pm 20\text{V}$	N-Ch			± 100	nA
		$V_{DS} = 0\text{V}, V_{GS} = \pm 20\text{V}$	P-Ch			± 100	
Zero Gate Voltage Drain Current	I_{DSS}	$V_{DS} = 24\text{V}, V_{GS} = 0\text{V}$	N-Ch			1	
		$V_{DS} = -24\text{V}, V_{GS} = 0\text{V}$	P-Ch			-1	
		$V_{DS} = 24\text{V}, V_{GS} = 0\text{V}, T_J = 85^\circ\text{C}$	N-Ch			5	μA
		$V_{DS} = -24\text{V}, V_{GS} = 0\text{V}, T_J = 85^\circ\text{C}$	P-Ch			-5	
On State Drain Currenta	$I_{D(on)}$	$V_{DS} \geq 5\text{V}, V_{GS} = 10\text{V}$	N-Ch	10			A
		$V_{DS} \leq -5\text{V}, V_{GS} = -10\text{V}$	P-Ch	-10			
Drain Source On State Resistance*	$r_{DS(on)}$	$V_{GS} = 10\text{V}, I_D = 11.8\text{A}$	N-Ch		0.072	0.085	Ω
		$V_{GS} = -10\text{V}, I_D = -2.1\text{A}$	P-Ch		0.137	0.165	
		$V_{GS} = 4.5\text{V}, I_D = 2.2\text{A}$	N-Ch		0.120	0.143	
		$V_{GS} = -4.5\text{V}, I_D = -1.6\text{A}$	P-Ch		0.240	0.290	
Forward Transconductance*	g_{fs}	$V_{DS} = 15\text{V}, I_D = 2.9\text{A}$	N-Ch		6		S
		$V_{DS} = -15\text{V}, I_D = -2.1\text{A}$	P-Ch		3		
Diode Forward Voltage*	V_{SD}	$I_S = 0.9\text{A}, V_{GS} = 0\text{V}$	N-Ch		0.8	1.2	V
		$I_S = -0.9\text{A}, V_{GS} = 0\text{V}$	P-Ch		-0.8	-1.2	
Total Gate Charge	Q_g	N-Channel $V_{DS} = 15\text{V}, V_{GS} = 10\text{V}, I_D = 2.9\text{A}$	N-Ch		5	7.5	nC
Gate Source Charge	Q_{gs}	P-Channel	N-Ch		0.8		
			P-Ch		1.2		
Gate Drain Charge	Q_{gd}	$V_{DS} = -15\text{V}, V_{GS} = -10\text{V}, I_D = -2.1\text{A}$	N-Ch		1.0		
			P-Ch		0.9		
Turn On Time	$t_{d(on)}$	N Channel $V_{DD} = 15\text{V}, R_L = 15\Omega$	N-Ch		7	11	ns
Rise Time	t_r	$I_D = 1\text{A}, V_{GEN} = 10\text{V}, R_g = 6\Omega$	P-Ch		8	12	
			N-Ch		12	18	
Turn Off Delay Time	$t_{d(off)}$	P-Channel $V_{DD} = -15\text{V}, R_L = 15\Omega$	N-Ch		12	18	
			P-Ch		14	21	
Fall Time	t_f	$I_D = -1\text{A}, V_{GEN} = -10\text{V}, R_g = 6\Omega$	N-Ch		7	11	
			P-Ch		8	12	
Source-Drain Reverse Recovery Time	t_{rr}	$I_F = 0.9\text{A}, di/dt = 100\text{A}/\mu\text{s}$	N-Ch		40	80	
		$I_F = -0.9\text{A}, di/dt = 100\text{A}/\mu\text{s}$	P-Ch		40	80	

* Pulse test; pulse width $\leq 300 \mu\text{s}$, duty cycle $\leq 2\%$.