

isc Silicon PNP Darlington Power Transistor

2SB1382

DESCRIPTION

- Collector-Emitter Breakdown Voltage-
: $V_{(BR)CEO} = -120V(\text{Min})$
- High DC Current Gain-
: $h_{FE} = 2000(\text{Min.}) @ (I_C = -8A, V_{CE} = -4V)$
- Low Collector Saturation Voltage-
: $V_{CE(sat)} = -1.5V(\text{Max}) @ (I_C = -8A, I_B = -16mA)$
- Complement to Type 2SD2082

APPLICATIONS

- Designed for chopper regulator, DC motor driver and general purpose applications.

ABSOLUTE MAXIMUM RATINGS($T_a=25^\circ\text{C}$)

SYMBOL	PARAMETER	VALUE	UNIT
V_{CBO}	Collector-Base Voltage	-120	V
V_{CEO}	Collector-Emitter Voltage	-120	V
V_{EBO}	Emitter-Base Voltage	-6	V
I_C	Collector Current-Continuous	-16	A
I_{CM}	Collector Current-Peak	-26	A
I_B	Base Current-Continuous	-1	A
P_C	Collector Power Dissipation @ $T_C=25^\circ\text{C}$	75	W
T_J	Junction Temperature	150	$^\circ\text{C}$
T_{stg}	Storage Temperature	-55~150	$^\circ\text{C}$

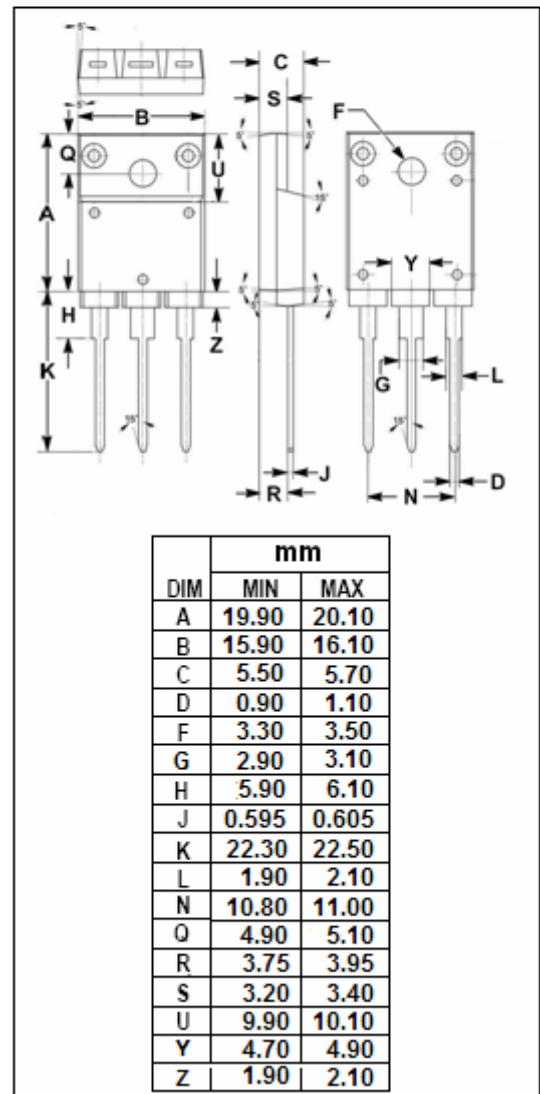
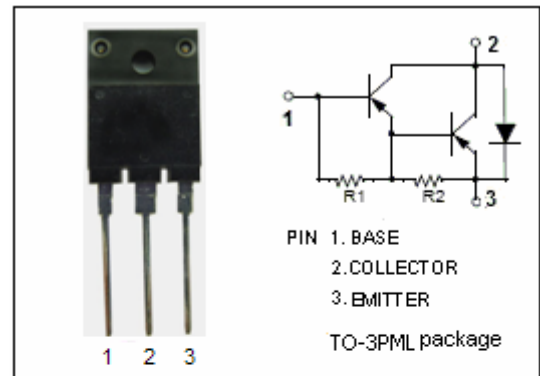

isc Silicon PNP Darlington Power Transistor

2SB1382

ELECTRICAL CHARACTERISTICS

T_j=25°C unless otherwise specified

SYMBOL	PARAMETER	CONDITIONS	MIN	TYP.	MAX	UNIT
V _{(BR)CEO}	Collector-Emitter Breakdown Voltage	I _C = -10mA ; I _B = 0	-120			V
V _{CE(sat)}	Collector-Emitter Saturation Voltage	I _C = -8A; I _B = -16mA			-1.5	V
V _{BE(sat)}	Base-Emitter Saturation Voltage	I _C = -8A; I _B = -16mA			-2.5	V
I _{CBO}	Collector Cutoff Current	V _{CB} = -120V ; I _E = 0			-10	μ A
I _{EBO}	Emitter Cutoff Current	V _{EB} = -6V; I _C = 0			-10	mA
h _{FE}	DC Current Gain	I _C = -8A ; V _{CE} = -4V	2000			
C _{OB}	Output Capacitance	I _E = 0; V _{CB} = -10V; f _{test} = 1MHz		350		pF
f _T	Current-Gain—Bandwidth Product	I _E = 1A ; V _{CE} = -12V		50		MHz

Switching Times

t _{on}	Turn-on Time	V _{CC} = -40V, R _L = 5 Ω, I _C = -8A; I _{B1} = -I _{B2} = -16mA,		0.8		μ s
t _{stg}	Storage Time			1.8		μ s
t _f	Fall Time			1.0		μ s