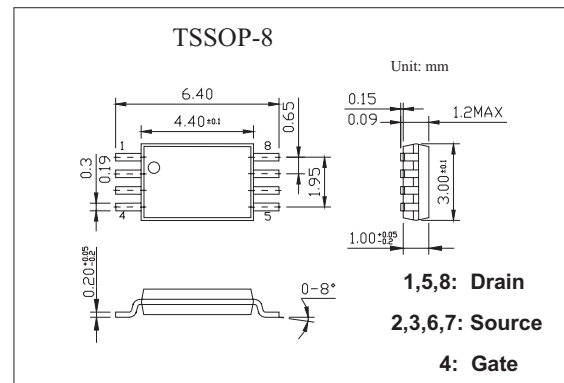
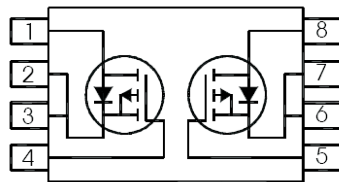

HEXFET[®] Power MOSFET

KRF7756

■ Features

- Ultra Low On-Resistance
- Dual P-Channel MOSFET
- Very Small SOIC Package
- Low Profile (< 1.2mm)
- Available in Tape & Reel

■ Absolute Maximum Ratings $T_a = 25^\circ\text{C}$

Parameter	Symbol	Rating	Unit
Drain- Source Voltage	V_{DS}	-12	V
Continuous Drain Current, $V_{GS} @ -4.5V @ T_A = 25^\circ\text{C}$	I_D	-4.3	A
Continuous Drain Current, $V_{GS} @ -4.5V @ T_A = 70^\circ\text{C}$	I_D	-3.5	
Pulsed Drain Current *1	I_{DM}	-17	
Power Dissipation *2 @ $T_A = 25^\circ\text{C}$	P_D	1.0	W
Power Dissipation *2 @ $T_A = 70^\circ\text{C}$	P_D	0.64	W
Linear Derating Factor		8	m W/ $^\circ\text{C}$
Gate-to-Source Voltage	V_{GS}	± 8	V
Junction and Storage Temperature Range	T_J, T_{STG}	-55 to + 150	$^\circ\text{C}$
Maximum Junction-to-Ambient *2	$R_{\theta JA}$	125	$^\circ\text{C}/\text{W}$

*1 Repetitive rating; pulse width limited by max. junction temperature.

*2 Surface mounted on FR-4 board, $\leq 10\text{sec}$

KRF7756

■ Electrical Characteristics Ta = 25°C

Parameter	Symbol	Testconditions	Min	Typ	Max	Unit
Drain-to-Source Breakdown Voltage	$V_{(BR)DSS}$	$V_{GS} = 0V, I_D = -250 \mu A$	-12			V
Breakdown Voltage Temp. Coefficient	$\Delta V_{(BR)DSS} / \Delta T_J$	$I_D = -1mA, \text{Reference to } 25^\circ C$		-0.006		V/°C
Static Drain-to-Source On-Resistance	$R_{DS(on)}$	$V_{GS} = -4.5V, I_D = -4.3A^{*1}$			0.040	Ω
		$V_{GS} = -2.5V, I_D = -3.4A^{*1}$			0.058	
		$V_{GS} = -1.8V, I_D = -2.2A^{*1}$			0.087	
Gate Threshold Voltage	$V_{GS(th)}$	$V_{DS} = V_{GS}, I_D = -250 \mu A$	-0.4		-0.9	V
Forward Transconductance	g_{fs}	$V_{DS} = -10V, I_D = -4.3A^{*1}$	13			S
Drain-to-Source Leakage Current	I_{DSS}	$V_{DS} = -9.6V, V_{GS} = 0V$			-1.0	μA
		$V_{DS} = -9.6V, V_{GS} = 0V, T_J = 70^\circ C$			-25	
Gate-to-Source Forward Leakage	I_{GSS}	$V_{GS} = -8.0V$			-100	nA
Gate-to-Source Reverse Leakage		$V_{GS} = 8.0V$			100	
Total Gate Charge	Q_g	$I_D = -4.3A$		12	18	nC
Gate-to-Source Charge	Q_{gs}	$V_{DS} = -6.0V$		1.8	2.7	
Gate-to-Drain ("Miller") Charge	Q_{gd}	$V_{GS} = -4.5V$		2.9	4.4	
Turn-On Delay Time	$t_{d(on)}$	$V_{DD} = -6V$		12		ns
Rise Time	t_r	$I_D = -1.0A$		18		
Turn-Off Delay Time	$t_{d(off)}$	$R_D = 6 \Omega$		160		
Fall Time	t_f	$V_{GS} = -4.5V$		170		
Input Capacitance	C_{iss}	$V_{GS} = 0V$		1400		pF
Output Capacitance	C_{oss}	$V_{DS} = -10V$		310		
Reverse Transfer Capacitance	C_{rss}	$f = 1.0MHz$		240		
Continuous Source Current (Body Diode)	I_S	MOSFET symbol showing the integral reverse p-n junction diode. 			-1.0	A
Pulsed Source Current (Body Diode) *2	I_{SM}				-17	
Diode Forward Voltage	V_{SD}	$T_J = 25^\circ C, I_S = -1.0A, V_{GS} = 0V^{*1}$			-1.2	V
Reverse Recovery Time	t_{rr}	$T_J = 25^\circ C, I_F = -1.0A$		35	53	ns
Reverse Recovery Charge	Q_{rr}	$di/dt = -100A/\mu s^{*1}$		20	30	nC

*1 Pulse width $\leq 400 \mu s$; duty cycle $\leq 2\%$.

*2 Repetitive rating; pulse width limited by max. junction temperature.