

High-voltage high and low side driver

Features

- High voltage rail up to 600 V
- dV/dt immunity ± 50 V/nsec in full temperature range
- Driver current capability:
 - 290 mA source,
 - 430 mA sink
- Switching times 75/35 nsec rise/fall with 1 nF load
- 3.3 V, 5 V TTL/CMOS inputs with hysteresis
- Integrated bootstrap diode
- Operational amplifier for advanced current sensing
- Comparator for fault protections
- Smart shut down function
- Adjustable dead-time
- Interlocking function
- Compact and simplified layout
- Bill of material reduction
- Effective fault protection
- Flexible, easy and fast design

Applications

Motor driver for home appliances, factory automation, industrial drives. HID ballasts, power supply units.

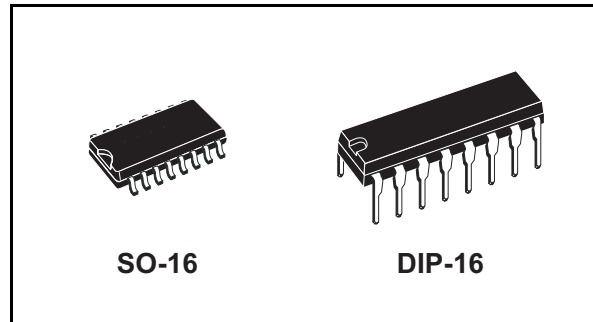

Description

The L6390 is a high-voltage device manufactured with the BCD "OFF-LINE" technology. It is a monolithic half-bridge gate driver for N-channel Power MOSFET or IGBT.

The high side (floating) section is designed to stand a voltage rail up to 600 V. The logic inputs are CMOS/TTL compatible down to 3.3 V for easy interfacing microcontroller/DSP.

The IC embeds an operational amplifier suitable for advanced current sensing in applications such as field oriented motor control.

An integrated comparator is available for protections against over-current, over-temperature, etc.

Table 1. Device summary

Order codes	Package	Packaging
L6390	DIP-16	Tube
L6390D	SO-16	Tube
L6390D013TR	SO-16	Tape and reel

Contents

1	Block diagram	3
2	Pin connection	4
3	Truth table	5
4	Electrical data	6
	4.1 Absolute maximum ratings	6
	4.2 Thermal data	6
	4.3 Recommended operating conditions	7
5	Electrical characteristics	8
	5.1 AC operation	8
	5.2 DC operation	10
6	Waveforms definitions	13
7	Smart shut down function	14
8	Typical application diagram	16
9	Bootstrap driver	17
	9.1 CBOOT selection and charging	17
10	Package mechanical data	19
11	Revision history	21

1 Block diagram

Figure 1. Block diagram

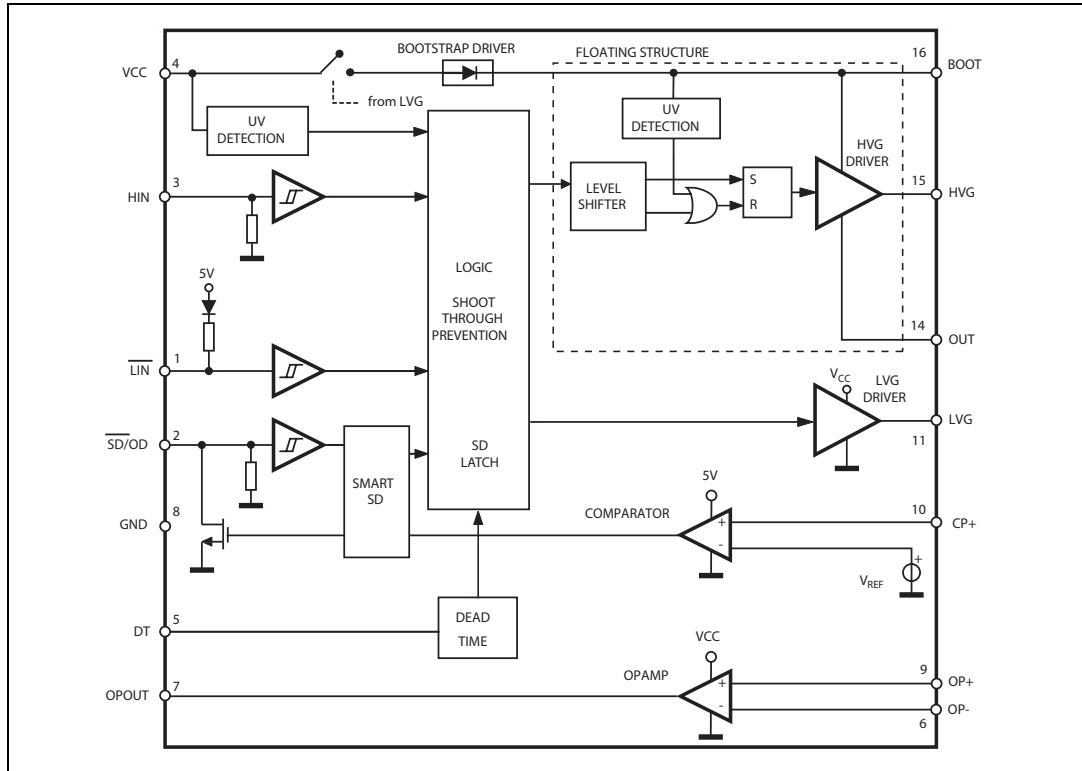

2 Pin connection

Figure 2. Pin connection (top view)

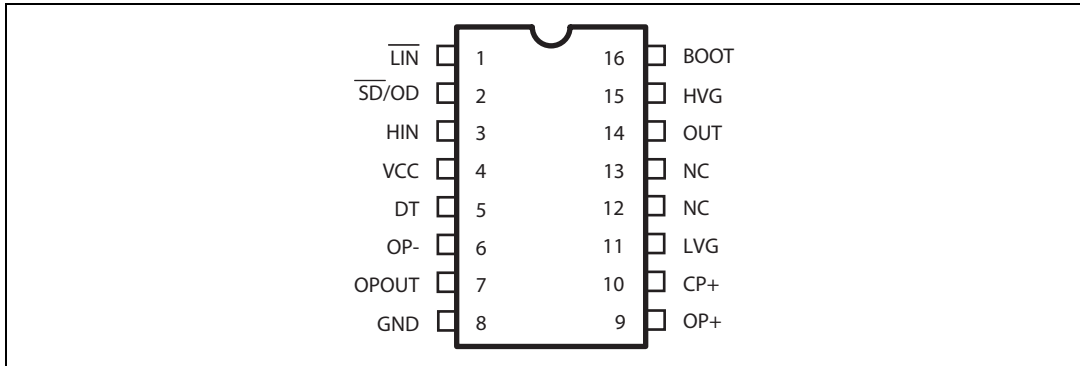

Table 2. Pin description

Pin n #	Pin name	Type	Function
1	$\overline{\text{LIN}}$	I	Low side driver logic input (active low)
2	$\overline{\text{SD/OD}}^{(1)}$	I/O	Shut down logic input (active low)/open drain (comparator output)
3	HIN	I	High side driver logic input (active high)
4	VCC	P	Lower section supply voltage
5	DT	I	Dead time setting
6	OP-	I	Opamp inverting input
7	OPOUT	O	Opamp output
8	GND	P	Ground
9	OP+	I	Opamp non inverting input
10	CP+	I	Comparator input
11	LVG ⁽¹⁾	O	Low side driver output
12, 13	NC		Not connected
14	OUT	P	High side (Floating) common voltage
15	HVG ⁽¹⁾	O	High side driver output
16	BOOT	P	Bootstrap supply voltage

1. The circuit provides less than 1 V on the LVG and HVG pins (@ $I_{\text{sink}} = 10 \text{ mA}$), with $V_{\text{CC}} > 3 \text{ V}$. This allows omitting the "bleeder" resistor connected between the gate and the source of the external MOSFET normally used to hold the pin low; the gate driver assures low impedance also in SD condition.

3 Truth table

Table 3. Truth table

Input			Output	
\overline{SD}	\overline{LIN}	HIN	LVG	HVG
L	X	X	L	L
H	H	L	L	L
H	L	H	L	L
H	L	L	H	L
H	H	H	L	H

Note: X: don't care

4 Electrical data

4.1 Absolute maximum ratings

Table 4. Absolute maximum rating

Symbol	Parameter	Value		Unit
		Min	Max	
V_{cc}	Supply voltage	- 0.3	21	V
V_{out}	Output voltage	$V_{boot} - 21$	$V_{boot} + 0.3$	V
V_{boot}	Bootstrap voltage	- 0.3	620	V
V_{hvg}	High side gate output voltage	$V_{out} - 0.3$	$V_{boot} + 0.3$	V
V_{lvg}	Low side gate output voltage	- 0.3	$V_{cc} + 0.3$	V
V_{op+}	OPAMP non-inverting input	- 0.3	$V_{cc} + 0.3$	V
V_{op-}	OPAMP inverting input	- 0.3	$V_{cc} + 0.3$	V
V_{cp+}	Comparator input voltage	- 0.3	$V_{cc} + 0.3$	V
V_i	Logic input voltage	- 0.3	15	V
V_{od}	Open drain voltage	- 0.3	15	V
dV_{out}/dt	Allowed output slew rate		50	V/ns
P_{tot}	Total power dissipation ($T_A = 25\text{ °C}$)		800	mW
T_J	Junction temperature		150	°C
T_{stg}	Storage temperature	-50	150	°C

4.2 Thermal data

Table 5. Thermal data

Symbol	Parameter	SO-16	DIP-16	Unit
$R_{th(JA)}$	Thermal resistance junction to ambient	155	100	°C/W

4.3 Recommended operating conditions

Table 6. Recommended operating conditions

Symbol	Pin	Parameter	Test condition	Min	Max	Unit
V_{cc}	4	Supply voltage		12.5	20	V
$V_{BO}^{(1)}$	16-14	Floating supply voltage		12.4	20	V
V_{out}	14	DC output voltage		- 9 ⁽²⁾	580	V
f_{sw}		Switching frequency	HVG, LVG load $C_L = 1$ nF		800	kHz
T_J		Junction temperature		-40	125	°C

- $V_{BO} = V_{boot} - V_{out}$
- LVG off. $V_{cc}=12.5$ V
Logic is operational if $V_{boot} > 5$ V
Refer to AN2378 for more details

5 Electrical characteristics

5.1 AC operation

Table 7. AC operation electrical characteristics ($V_{CC} = 15\text{ V}$; $T_J = +25\text{ }^\circ\text{C}$)

Symbol	Pin	Parameter	Test condition	Min	Typ	Max	Unit
t_{on}	1 vs 11	High/low side driver turn-on propagation delay	$V_{out} = 0\text{ V}$		125	200	ns
t_{off}	3 vs 15	High/low side driver turn-off propagation delay	$V_{boot} = V_{CC}$ $C_L = 1\text{ nF}$		125	200	ns
t_{sd}	2 vs 11, 15	Shut down to high/low side driver propagation delay	$V_i = 0\text{ to }3.3\text{ V}$ See Figure 3 .		125	200	ns
t_{isd}		Comparator triggering to high/low side driver turn-off propagation delay	Measured applying a voltage step from 0 V to 3.3 V to pin CP+.		200	250	ns
MT		Delay matching, HS and LS turn-on/off				40	ns
dt	5	Dead time setting range	$R_{dt} = 0, C_L = 1\text{ nF}, C_{DT} = 100\text{ nF}$	0.1	0.18	0.25	μs
			$R_{dt} = 37\text{ k}\Omega, C_L = 1\text{ nF}, C_{DT} = 100\text{ nF}$	0.48	0.6	0.72	μs
			$R_{dt} = 136\text{ k}\Omega, C_L = 1\text{ nF}, C_{DT} = 100\text{ nF}$	1.35	1.6	1.85	μs
			$R_{dt} = 260\text{ k}\Omega, C_L = 1\text{ nF}, C_{DT} = 100\text{ nF}$	2.6	3.0	3.4	μs
MDT		Matching dead time	$R_{dt} = 0, C_L = 1\text{ nF}, C_{DT} = 100\text{ nF}$			60	ns
			$R_{dt} = 37\text{ k}\Omega, C_L = 1\text{ nF}, C_{DT} = 100\text{ nF}$			100	ns
			$R_{dt} = 136\text{ k}\Omega, C_L = 1\text{ nF}, C_{DT} = 100\text{ nF}$			240	ns
			$R_{dt} = 260\text{ k}\Omega, C_L = 1\text{ nF}, C_{DT} = 100\text{ nF}$			350	ns
t_r	11, 15	Rise time	$C_L = 1\text{ nF}$		75	120	ns
t_f		Fall time	$C_L = 1\text{ nF}$		35	70	ns

Figure 3. Timing

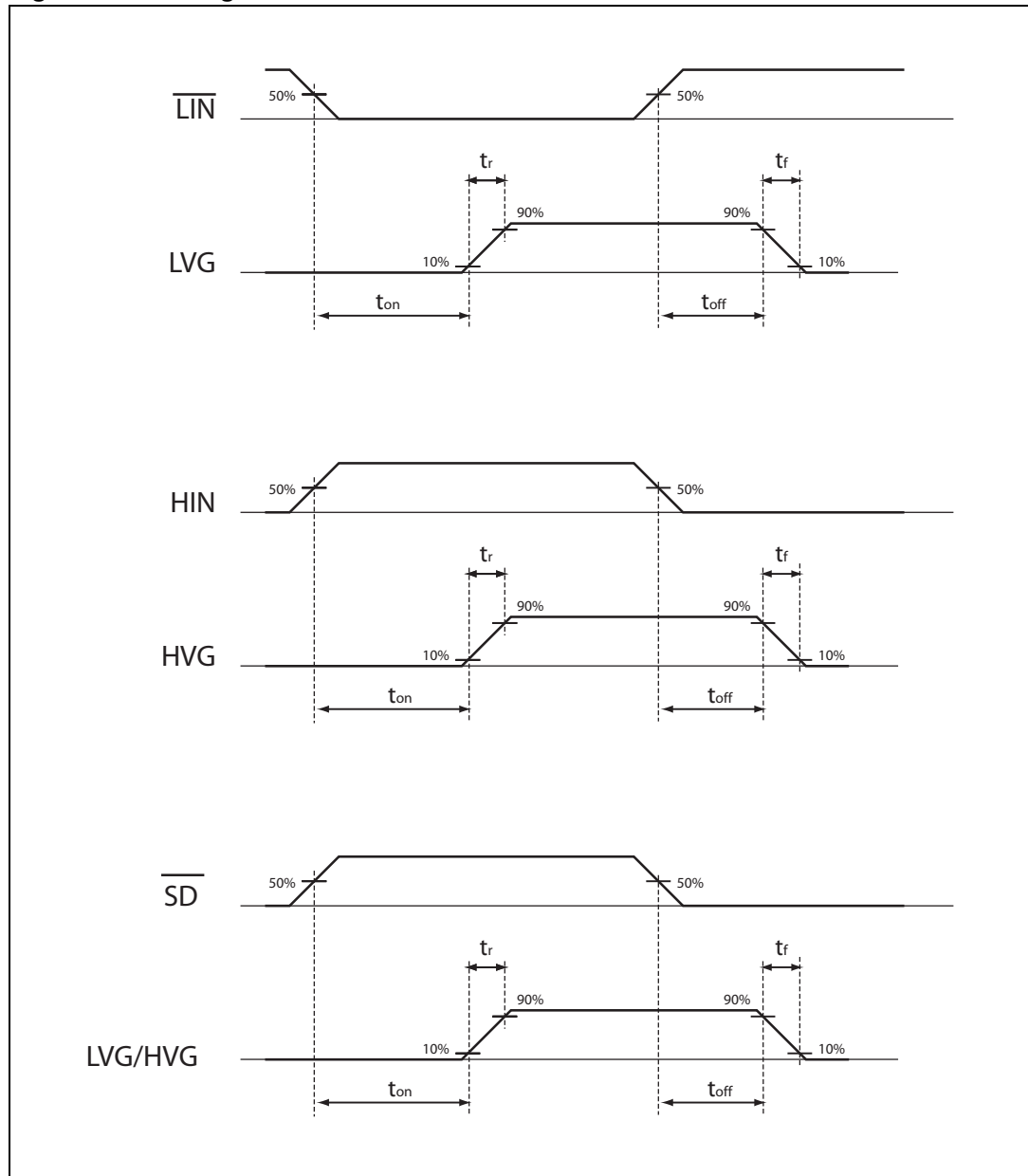

5.2 DC operation

Table 8. DC operation electrical characteristics ($V_{CC} = 15\text{ V}$; $T_J = +25\text{ }^\circ\text{C}$)

Symbol	Pin	Parameter	Test condition	Min	Typ	Max	Unit	
Low supply voltage section								
V_{CC_hys}	4	V_{CC} UV hysteresis		1200	1500	1800	mV	
V_{CC_thON}		V_{CC} UV turn ON threshold		11.5	12	12.5	V	
V_{CC_thOFF}		V_{CC} UV turn OFF threshold		10	10.5	11	V	
I_{qccu}		Undervoltage quiescent supply current	$V_{CC} = 10\text{ V}$ $\overline{SD} = 5\text{ V}$; $\overline{LIN} = 5\text{ V}$; HIN = GND; $R_{DT} = 0\ \Omega$; CP+=OP+=GND; OP-=5 V			120	150	μA
I_{qcc}		Quiescent current	$V_{CC} = 15\text{ V}$ $\overline{SD} = 5\text{ V}$; $\overline{LIN} = 5\text{ V}$; HIN = GND; $R_{DT} = 0\ \Omega$; CP+=OP+=GND; OP-=5 V			720	1000	μA
V_{ref}		Internal reference voltage		500	540	580	mV	
Bootstrapped supply voltage section ⁽¹⁾								
V_{BO_hys}	16	V_{BO} UV hysteresis		1200	1500	1800	mV	
V_{BO_thON}		V_{BO} UV turn ON threshold		10.6	11.5	12.4	V	
V_{BO_thOFF}		V_{BO} UV turn OFF threshold		9.1	10	10.9	V	
I_{QBOU}		Undervoltage V_{BO} quiescent current	$V_{BO} = 9\text{ V}$ $\overline{SD} = 5\text{ V}$; \overline{LIN} and HIN = 5 V; $R_{DT} = 0\ \Omega$; CP+=OP+=GND; OP-=5 V			70	110	μA
I_{QBO}		V_{BO} quiescent current	$V_{BO} = 15\text{ V}$ $\overline{SD} = 5\text{ V}$; \overline{LIN} and HIN = 5 V; $R_{DT} = 0\ \Omega$; CP+=OP+=GND; OP-=5 V			150	210	μA
I_{LK}		High voltage leakage current	$V_{hvg} = V_{out} = V_{boot} = 600\text{ V}$			10	μA	
$R_{DS(on)}$		Bootstrap driver on resistance ⁽²⁾	LVG ON			120	Ω	
Driving buffers section								
I_{so}	11, 15	High/low side source short circuit current	$V_{IN} = V_{ih}$ ($t_p < 10\ \mu\text{s}$)	200	290		mA	
I_{si}		High/low side sink short circuit current	$V_{IN} = V_{il}$ ($t_p < 10\ \mu\text{s}$)	250	430		mA	

Table 8. DC operation electrical characteristics ($V_{CC} = 15\text{ V}$; $T_J = +25\text{ °C}$) (continued)

Symbol	Pin	Parameter	Test condition	Min	Typ	Max	Unit
Logic inputs							
V_{il}	1, 2, 3	Low logic level voltage				0.8	V
V_{ih}		High logic level voltage		2.25			V
I_{HINh}	3	HIN logic "1" input bias current	HIN = 15 V		175	260	μA
I_{HINl}		HIN logic "0" input bias current	HIN = 0 V			1	μA
I_{LINl}	1	$\overline{\text{LIN}}$ logic "0" input bias current	$\overline{\text{LIN}} = 0\text{ V}$		6	20	μA
I_{LINh}		$\overline{\text{LIN}}$ logic "1" input bias current	$\overline{\text{LIN}} = 15\text{ V}$			1	μA
I_{SDh}	2	$\overline{\text{SD}}$ logic "1" input bias current	$\overline{\text{SD}} = 15\text{ V}$		40	100	μA
I_{SDl}		$\overline{\text{SD}}$ logic "0" input bias current	$\overline{\text{SD}} = 0\text{ V}$			1	μA

1. $V_{BO} = V_{boot} - V_{out}$

2. R_{DSON} is tested in the following way:

$$R_{DSON} = [(V_{CC} - V_{CBOOT1}) - (V_{CC} - V_{CBOOT2})] / [I_1(V_{CC}, V_{CBOOT1}) - I_2(V_{CC}, V_{CBOOT2})]$$

where I_1 is pin 16 current when $V_{CBOOT} = V_{CBOOT1}$, I_2 when $V_{CBOOT} = V_{CBOOT2}$.

Table 9. OPAMP characteristics ($V_{CC} = 15\text{ V}$, $T_J = +25\text{ °C}$)

Symbol	Pin	Parameter	Test condition	Min	Typ	Max	Unit
I_{ib}	6, 9	Input bias current ⁽¹⁾			100	200	nA
V_{icm}		Input common mode voltage range		0			V
V_{OL}	7	Low level output voltage	$V_{id} = \pm 1\text{ V}$, $R_L = 10\text{ k}\Omega$ to V_{CC}		75		mV
V_{OH}		High level output voltage	$V_{id} = \pm 1\text{ V}$, $R_L = 10\text{ k}\Omega$ to GND		14.7		V
I_o		Output short circuit current	Source, $V_{id} = \pm 1$; $V_o = 0\text{ V}$	16	30		mA
		Sink, $V_{id} = \pm 1$; $V_o = V_{CC}$	50	80		mA	
SR		Slew rate	$V_i = 1 \div 4\text{ V}$; $R_L = 2\text{ k}\Omega$; $C_L = 100\text{ pF}$; unity gain	2.5	3.8		V/ μ s
GBWP		Gain bandwidth product	$V_o = 7.5\text{ V}$; $R_L = 2\text{ k}\Omega$		12		MHz
A_{vd}		Large signal voltage gain		75	85		dB
SVR		Supply voltage rejection ratio		60	70		dB
CMRR		Common mode rejection ratio			70		dB

1. The direction of input current is out of the IC.

Table 10. Sense comparator characteristics ($V_{CC} = 15\text{ V}$, $T_J = +25\text{ °C}$)

Symbol	Pin	Parameter	Test conditions	Min	Typ	Max	Unit
I_{io}	10	Input bias current	$V_{CP+} = 1\text{ V}$			1	μ A
V_{ol}	2	Open drain low level output voltage	$I_{od} = -3\text{ mA}$			0.5	V
t_{d_comp}		Comparator delay	\overline{SD}/OD pulled to 5 V through 100 k Ω resistor		90	130	ns
SR	2	Slew rate	$C_L = 180\text{ pF}$; $R_{pu} = 5\text{ k}\Omega$		60		V/ μ sec

6 Waveforms definitions

Figure 4. Dead time and interlocking waveforms definitions

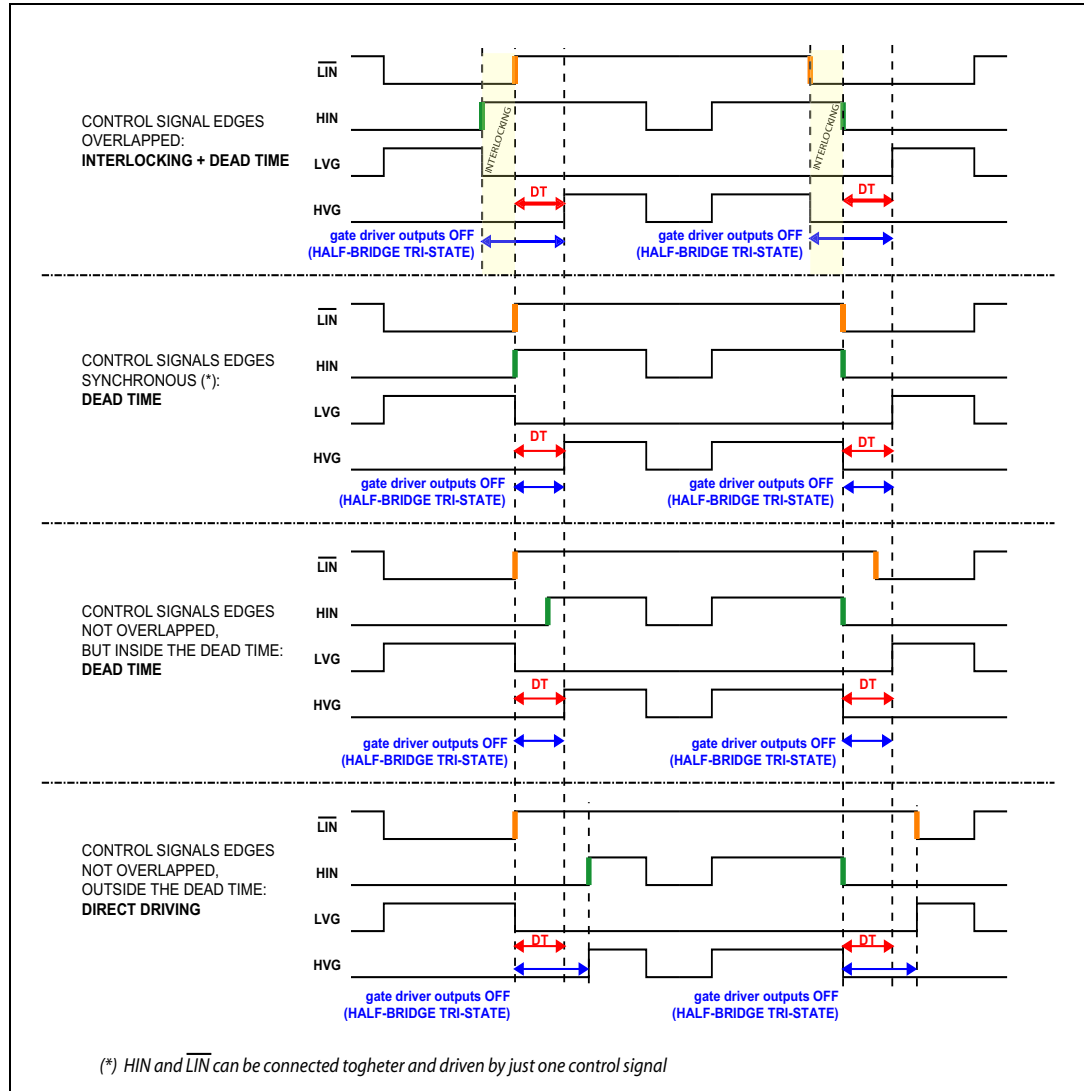

7 Smart shut down function

L6390 integrates a comparator committed to the fault sensing function. The comparator has an internal voltage reference V_{ref} connected to the inverting input, while the non-inverting input is available on pin 10. The comparator input can be connected to an external shunt resistor in order to implement a simple over-current detection function. The output signal of the comparator is fed to an integrated MOSFET with the open drain output available on pin 2, shared with the \overline{SD} input. When the comparator triggers, the device is set in shut down state and both its outputs are set to low level leaving the half-bridge in tri-state.

Figure 5. Smart shut down timing waveforms

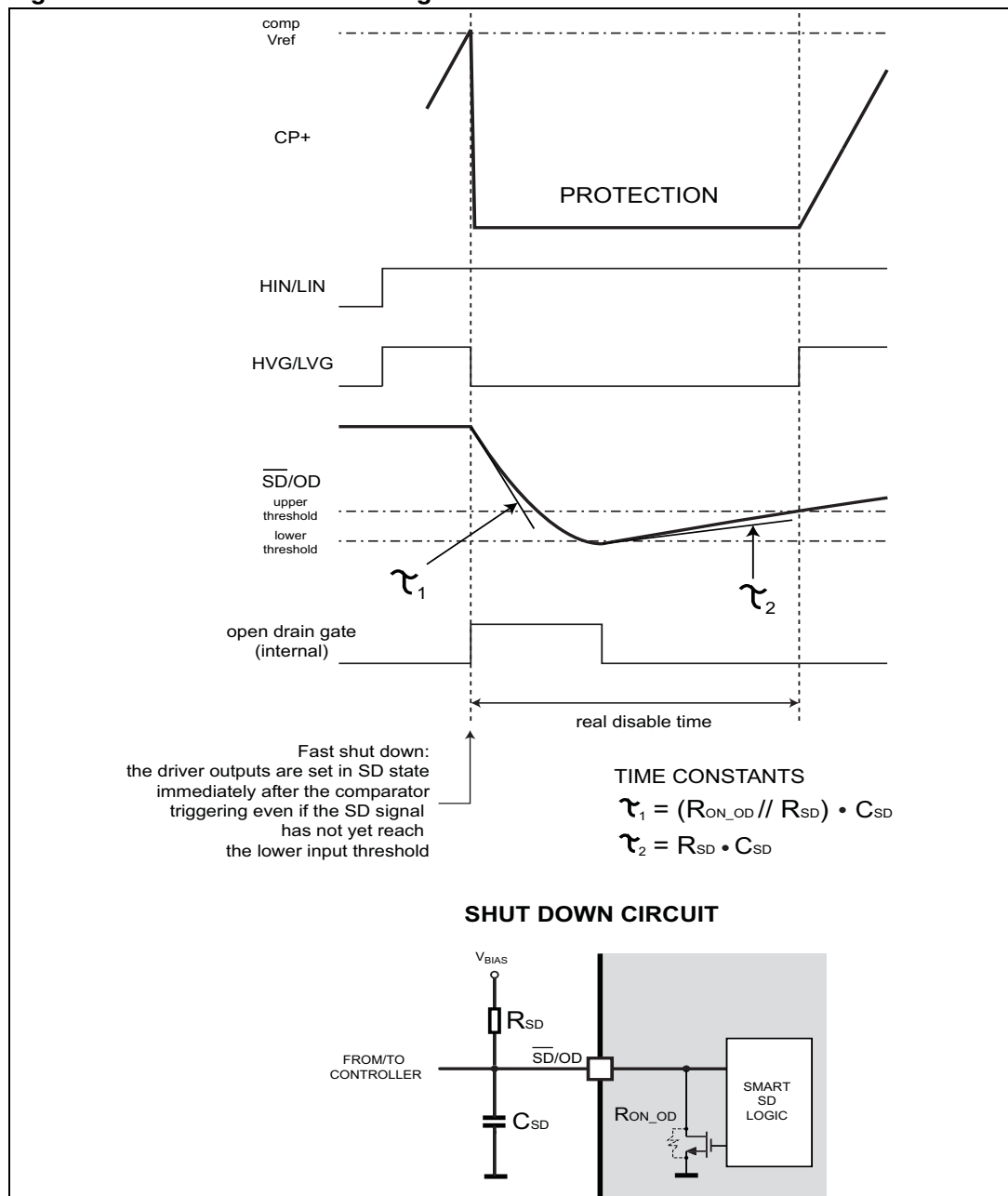

In common over-current protection architectures the comparator output is usually connected to the \overline{SD} input and an RC network is connected to this \overline{SD}/OD line in order to provide a mono-stable circuit, which implements a protection time that follows the fault condition. Differently from the common fault detection systems, L6390 Smart shut down architecture allows to immediately turn-off the outputs gate driver in case of fault, by minimizing the propagation delay between the fault detection event and the actual outputs switch-off. In fact the time delay between the fault and the outputs turn off is no more dependent on the RC value of the external network connected to the pin. In the Smart shut down circuitry, the fault signal has a preferential path which directly switch off the outputs after the comparator triggering. At the same time the internal logic turns on the open drain output and holds it on until the \overline{SD} voltage goes below the \overline{SD} logic input lower threshold. The Smart shut down system provides the possibility to increase the time constant of the external RC network (that is the disable time after the fault event) up to very large values without increasing the delay time of the protection.

Any external signal provided to the \overline{SD} pin is not latched and can be used as control signal in order to perform, for instance, PWM chopping through this pin. In fact when a PWM signal is applied to the \overline{SD} input and the logic inputs of the gate driver are stable, the outputs switch from the low level to the state defined by the logic inputs and vice versa.

8 Typical application diagram

Figure 6. Application diagram

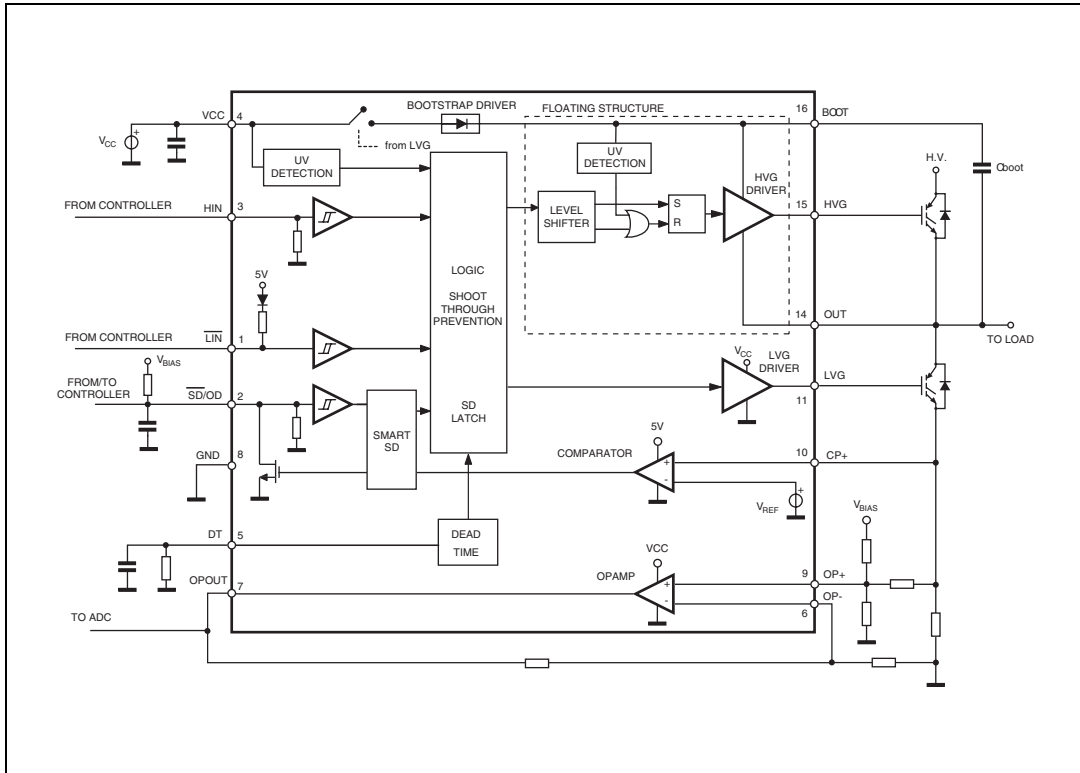

9 Bootstrap driver

A bootstrap circuitry is needed to supply the high voltage section. This function is normally accomplished by a high voltage fast recovery diode ([Figure 7.a](#)). In the L6390 a patented integrated structure replaces the external diode. It is realized by a high voltage DMOS, driven synchronously with the low side driver (LVG), with diode in series, as shown in [Figure 7.b](#).

An internal charge pump ([Figure 7.b](#)) provides the DMOS driving voltage.

9.1 C_{BOOT} selection and charging

To choose the proper C_{BOOT} value the external MOS can be seen as an equivalent capacitor. This capacitor C_{EXT} is related to the MOS total gate charge:

Equation 1

$$C_{EXT} = \frac{Q_{gate}}{V_{gate}}$$

The ratio between the capacitors C_{EXT} and C_{BOOT} is proportional to the cyclical voltage loss. It has to be:

Equation 2

$$C_{BOOT} \gg \gg C_{EXT}$$

e.g.: if Q_{gate} is 30 nC and V_{gate} is 10 V, C_{EXT} is 3 nF. With C_{BOOT} = 100 nF the drop would be 300 mV.

If HVG has to be supplied for a long time, the C_{BOOT} selection has to take into account also the leakage and quiescent losses.

e.g.: HVG steady state consumption is lower than 200 μA, so if HVG T_{ON} is 5 ms, C_{BOOT} has to supply 1 μC to C_{EXT}. This charge on a 1 μF capacitor means a voltage drop of 1V.

The internal bootstrap driver gives a great advantage: the external fast recovery diode can be avoided (it usually has great leakage current).

This structure can work only if V_{OUT} is close to GND (or lower) and in the meanwhile the LVG is on. The charging time (T_{charge}) of the C_{BOOT} is the time in which both conditions are fulfilled and it has to be long enough to charge the capacitor.

The bootstrap driver introduces a voltage drop due to the DMOS R_{DSON} (typical value: 120 Ω). At low frequency this drop can be neglected. Anyway increasing the frequency it must be taken in to account.

The following equation is useful to compute the drop on the bootstrap DMOS:

Equation 3

$$V_{\text{drop}} = I_{\text{charge}} R_{\text{dson}} \rightarrow V_{\text{drop}} = \frac{Q_{\text{gate}}}{T_{\text{charge}}} R_{\text{dson}}$$

where Q_{gate} is the gate charge of the external power MOS, R_{dson} is the on resistance of the bootstrap DMOS and T_{charge} is the charging time of the bootstrap capacitor.

For example: using a power MOS with a total gate charge of 30nC the drop on the bootstrap DMOS is about 1V, if the T_{charge} is 5µs. In fact:

Equation 4

$$V_{\text{drop}} = \frac{30\text{nC}}{5\mu\text{s}} \cdot 120\Omega \sim 0.7\text{V}$$

V_{drop} has to be taken into account when the voltage drop on C_{BOOT} is calculated: if this drop is too high, or the circuit topology doesn't allow a sufficient charging time, an external diode can be used.

Figure 7. Bootstrap driver

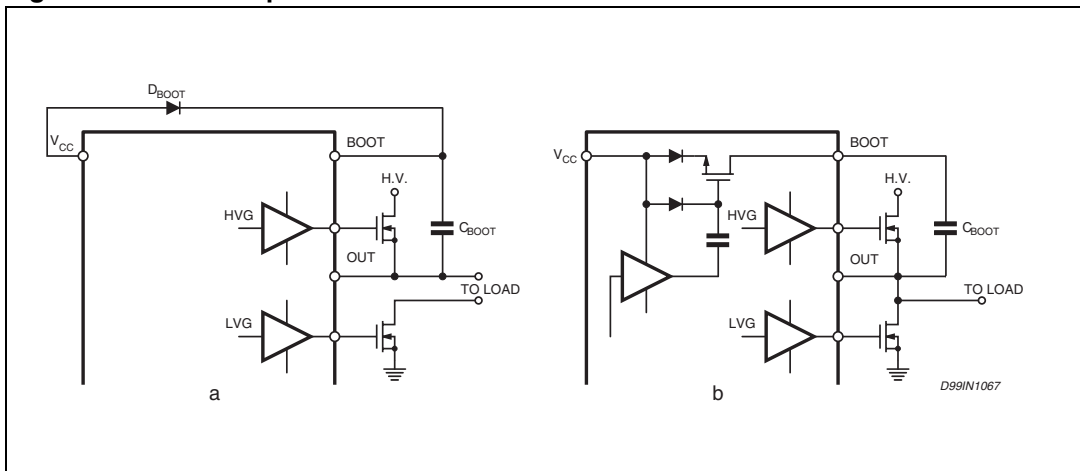

10 Package mechanical data

In order to meet environmental requirements, ST offers these devices in ECOPACK® packages. These packages have a lead-free second level interconnect. The category of second level interconnect is marked on the package and on the inner box label, in compliance with JEDEC Standard JESD97. The maximum ratings related to soldering conditions are also marked on the inner box label. ECOPACK is an ST trademark. ECOPACK specifications are available at: www.st.com

Figure 8. DIP-16 mechanical data and package dimensions

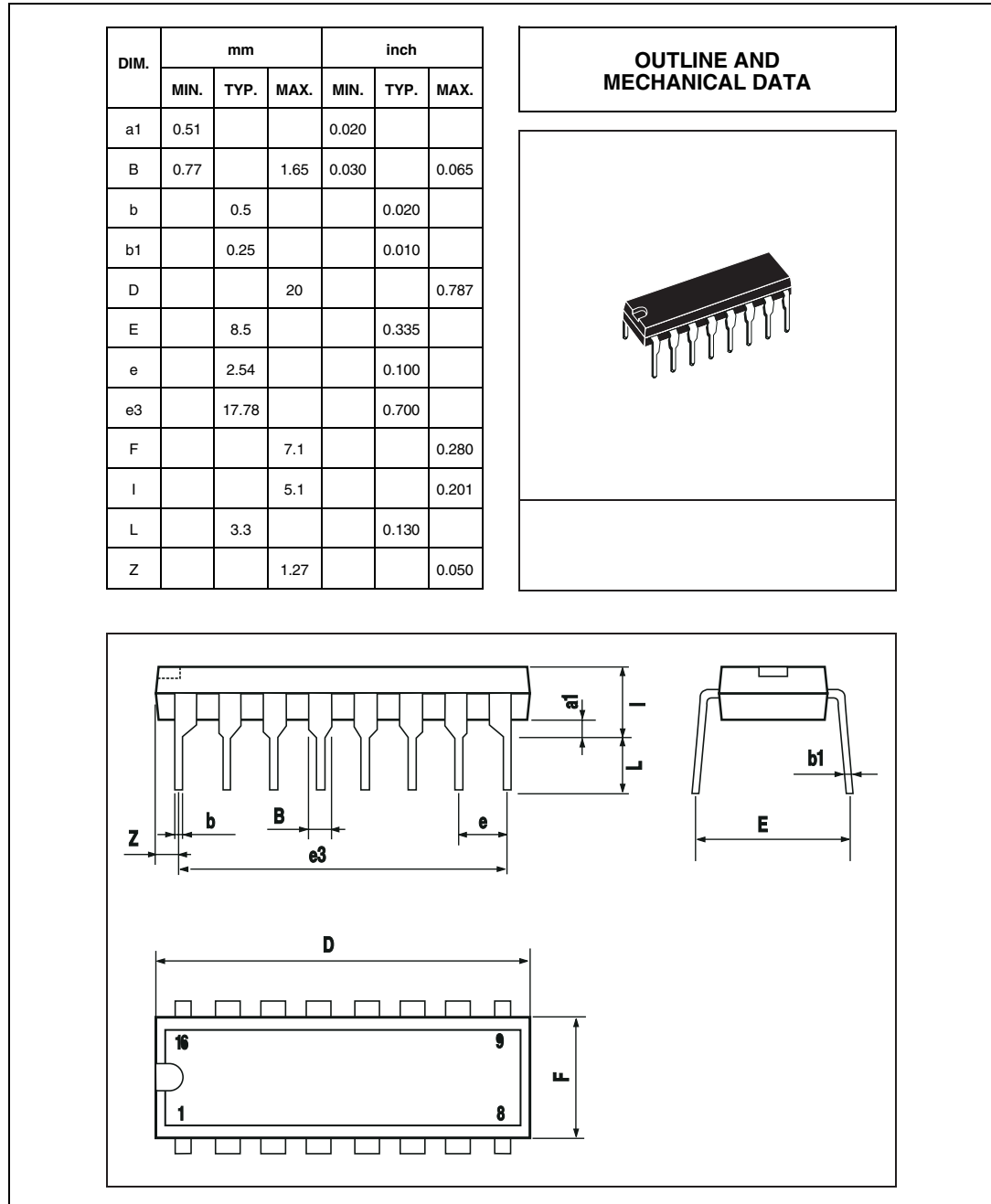
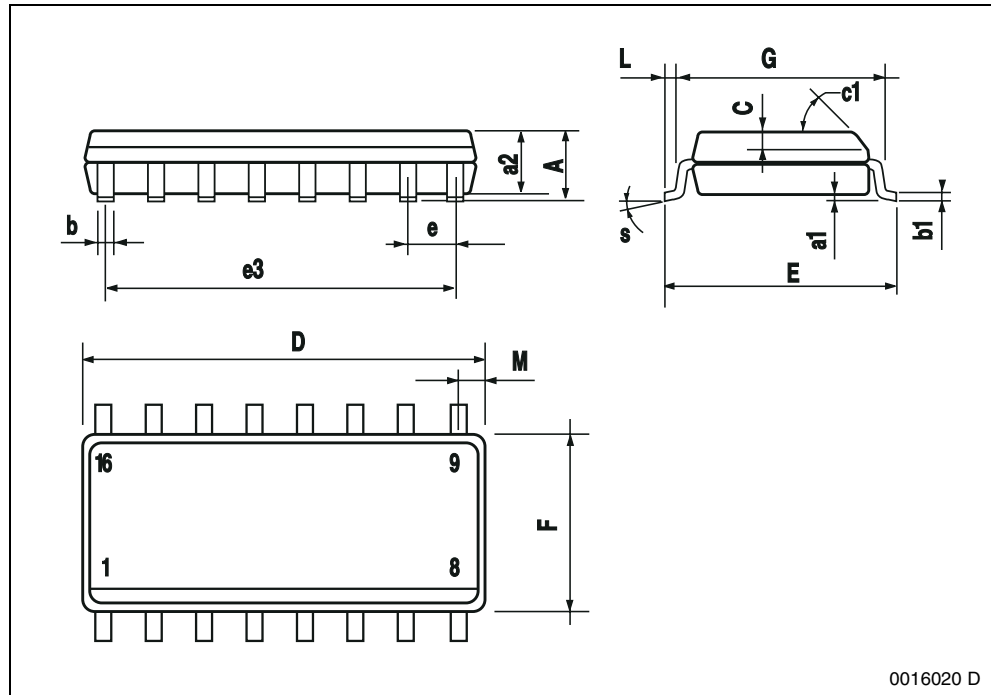
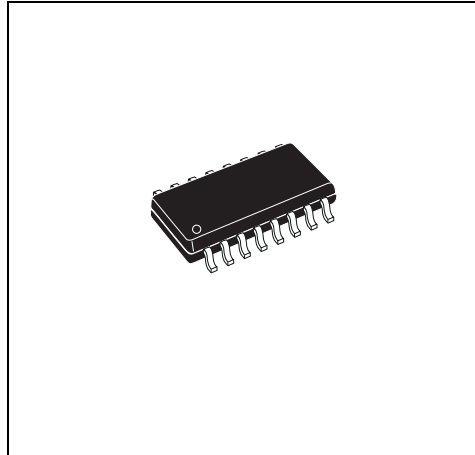

Figure 9. SO-16 narrow mechanical data and package dimensions

DIM.	mm			inch		
	MIN.	TYP.	MAX.	MIN.	TYP.	MAX.
A			1.75			0.069
a1	0.1		0.25	0.004		0.009
a2			1.6			0.063
b	0.35		0.46	0.014		0.018
b1	0.19		0.25	0.007		0.010
C		0.5			0.020	
c1			45°	(typ.)		
D ⁽¹⁾	9.8		10	0.386		0.394
E	5.8		6.2	0.228		0.244
e		1.27			0.050	
e3		8.89			0.350	
F ⁽¹⁾	3.8		4.0	0.150		0.157
G	4.60		5.30	0.181		0.208
L	0.4		1.27	0.150		0.050
M			0.62			0.024
S	8° (max.)					

(1) "D" and "F" do not include mold flash or protrusions - Mold flash or protrusions shall not exceed 0.15mm (.006inc.)

OUTLINE AND MECHANICAL DATA



0016020 D

11 Revision history

Table 11. Document revision history

Date	Revision	Changes
29-Feb-2008	1	First release
09-Jul-2008	2	Updated: Cover page, Table 2 on page 4 , Table 3 on page 5 , Section 4 on page 6 , Section 5 on page 8 , Section 9.1 on page 17
17-Jul-2008	3	Updated test condition values on Table 8 and Table 9

Please Read Carefully:

Information in this document is provided solely in connection with ST products. STMicroelectronics NV and its subsidiaries ("ST") reserve the right to make changes, corrections, modifications or improvements, to this document, and the products and services described herein at any time, without notice.

All ST products are sold pursuant to ST's terms and conditions of sale.

Purchasers are solely responsible for the choice, selection and use of the ST products and services described herein, and ST assumes no liability whatsoever relating to the choice, selection or use of the ST products and services described herein.

No license, express or implied, by estoppel or otherwise, to any intellectual property rights is granted under this document. If any part of this document refers to any third party products or services it shall not be deemed a license grant by ST for the use of such third party products or services, or any intellectual property contained therein or considered as a warranty covering the use in any manner whatsoever of such third party products or services or any intellectual property contained therein.

UNLESS OTHERWISE SET FORTH IN ST'S TERMS AND CONDITIONS OF SALE ST DISCLAIMS ANY EXPRESS OR IMPLIED WARRANTY WITH RESPECT TO THE USE AND/OR SALE OF ST PRODUCTS INCLUDING WITHOUT LIMITATION IMPLIED WARRANTIES OF MERCHANTABILITY, FITNESS FOR A PARTICULAR PURPOSE (AND THEIR EQUIVALENTS UNDER THE LAWS OF ANY JURISDICTION), OR INFRINGEMENT OF ANY PATENT, COPYRIGHT OR OTHER INTELLECTUAL PROPERTY RIGHT.

UNLESS EXPRESSLY APPROVED IN WRITING BY AN AUTHORIZED ST REPRESENTATIVE, ST PRODUCTS ARE NOT RECOMMENDED, AUTHORIZED OR WARRANTED FOR USE IN MILITARY, AIR CRAFT, SPACE, LIFE SAVING, OR LIFE SUSTAINING APPLICATIONS, NOR IN PRODUCTS OR SYSTEMS WHERE FAILURE OR MALFUNCTION MAY RESULT IN PERSONAL INJURY, DEATH, OR SEVERE PROPERTY OR ENVIRONMENTAL DAMAGE. ST PRODUCTS WHICH ARE NOT SPECIFIED AS "AUTOMOTIVE GRADE" MAY ONLY BE USED IN AUTOMOTIVE APPLICATIONS AT USER'S OWN RISK.

Resale of ST products with provisions different from the statements and/or technical features set forth in this document shall immediately void any warranty granted by ST for the ST product or service described herein and shall not create or extend in any manner whatsoever, any liability of ST.

ST and the ST logo are trademarks or registered trademarks of ST in various countries.

Information in this document supersedes and replaces all information previously supplied.

The ST logo is a registered trademark of STMicroelectronics. All other names are the property of their respective owners.

© 2008 STMicroelectronics - All rights reserved

STMicroelectronics group of companies

Australia - Belgium - Brazil - Canada - China - Czech Republic - Finland - France - Germany - Hong Kong - India - Israel - Italy - Japan - Malaysia - Malta - Morocco - Singapore - Spain - Sweden - Switzerland - United Kingdom - United States of America

www.st.com