

isc Silicon PNP Power Transistor

2SB993

DESCRIPTION

- Collector-Emitter Breakdown Voltage-
: $V_{(BR)CEO} = -50V(\text{Min})$
- Collector Power Dissipation-
: $P_C = 40W @ T_C = 25^\circ C$
- Low Collector Saturation Voltage-
: $V_{CE(sat)} = -0.4V(\text{Max}) @ I_C = -4A$
- Complement to Type 2SD1363

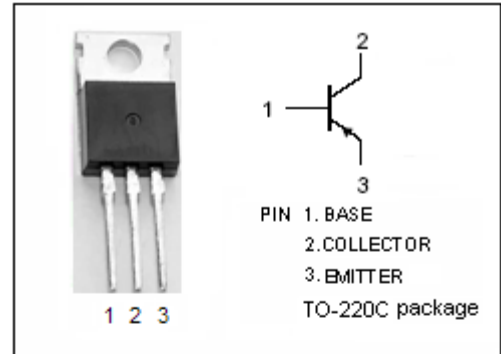

APPLICATIONS

- High current switching applications.
- Power amplifier applications.

ABSOLUTE MAXIMUM RATINGS($T_a=25^\circ C$)

SYMBOL	PARAMETER	VALUE	UNIT
V_{CBO}	Collector-Base Voltage	-70	V
V_{CEO}	Collector-Emitter Voltage	-50	V
V_{EBO}	Emitter-Base Voltage	-5	V
I_C	Collector Current-Continuous	-7	A
I_B	Base Current-Continuous	-1	A
P_C	Collector Power Dissipation @ $T_a=25^\circ C$	1.5	W
	Collector Power Dissipation @ $T_C=25^\circ C$	40	
T_J	Junction Temperature	150	$^\circ C$
T_{stg}	Storage Temperature	-55~150	$^\circ C$

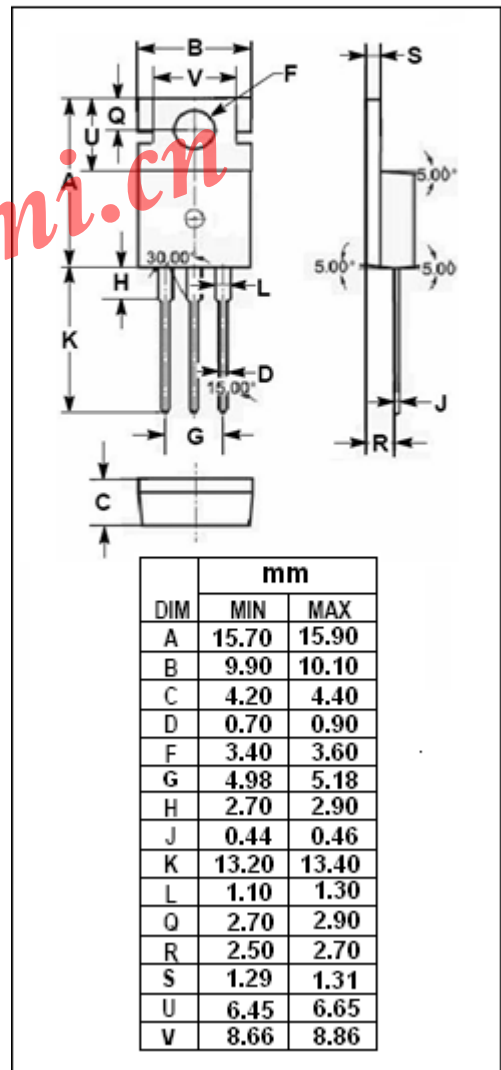

isc Silicon PNP Power Transistor

2SB993

ELECTRICAL CHARACTERISTICS

T_j=25°C unless otherwise specified

SYMBOL	PARAMETER	CONDITIONS	MIN	TYP.	MAX	UNIT
V _{(BR)CEO}	Collector-Emitter Breakdown Voltage	I _C = -50mA; I _B = 0	-50			V
V _{CE(sat)}	Collector-Emitter Saturation Voltage	I _C = -4A; I _B = -0.4A			-0.4	V
V _{BE(sat)}	Base-Emitter Saturation Voltage	I _C = -4A; I _B = -0.4A			-1.2	V
I _{CBO}	Collector Cutoff Current	V _{CB} = -70V; I _E = 0			-30	μ A
I _{EBO}	Emitter Cutoff Current	V _{EB} = -5V; I _C = 0			-50	μ A
h _{FE-1}	DC Current Gain	I _C = -1A; V _{CE} = -1V	70		240	
h _{FE-2}	DC Current Gain	I _C = -4A; V _{CE} = -1V	30			
C _{OB}	Output Capacitance	I _E = 0; V _{CB} = -10V; f _{test} = 1MHz		250		pF
f _T	Current-Gain—Bandwidth Product	I _C = -1A; V _{CE} = -4V		10		MHz

Switching Times

t _{on}	Turn-on Time	V _{CC} = -30V, R _L = 10 Ω, I _{B1} = -I _{B2} = -0.3A,		0.2		μ s
t _{stg}	Storage Time			2.5		μ s
t _f	Fall Time			0.5		μ s

◆ h_{FE-1} Classifications

O	Y
70-140	120-240