

**Silicon NPN Power Transistors**

**2SC5197**

**DESCRIPTION**

- With TO-3P(I) package
- Complement to type 2SA1940

**APPLICATIONS**

- Power amplifier applications
- Recommend for 55W high fidelity audio frequency amplifier output stage

**PINNING**

PIN	DESCRIPTION
1	Base
2	Collector;connected to mounting base
3	Emitter

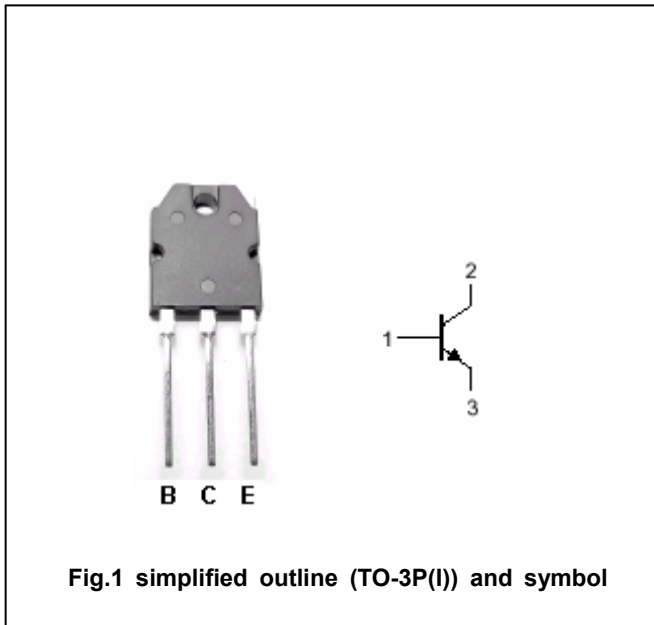

**Absolute maximum ratings(Ta=□)**

SYMBOL	PARAMETER	CONDITIONS	VALUE	UNIT
$V_{CBO}$	Collector-base voltage	Open emitter	120	V
$V_{CEO}$	Collector-emitter voltage	Open base	120	V
$V_{EBO}$	Emitter-base voltage	Open collector	5	V
$I_C$	Collector current		8	A
$I_B$	Base current		0.8	A
$P_C$	Collector power dissipation	$T_C=25□$	80	W
$T_j$	Junction temperature		150	□
$T_{stg}$	Storage temperature		-55~150	□

## Silicon NPN Power Transistors

## 2SC5197

## CHARACTERISTICS

T<sub>j</sub>=25°C unless otherwise specified

SYMBOL	PARAMETER	CONDITIONS	MIN	TYP.	MAX	UNIT
V <sub>(BR)CEO</sub>	Collector-emitter breakdown voltage	I <sub>C</sub> =50mA; I <sub>B</sub> =0	120			V
V <sub>CEsat</sub>	Collector-emitter saturation voltage	I <sub>C</sub> =6 A; I <sub>B</sub> =0.6A			2.0	V
V <sub>BE</sub>	Base-emitter voltage	I <sub>C</sub> =4A ; V <sub>CE</sub> =5V			1.5	V
I <sub>CBO</sub>	Collector cut-off current	V <sub>CB</sub> =120V; I <sub>E</sub> =0			5	μA
I <sub>EBO</sub>	Emitter cut-off current	V <sub>EB</sub> =5V; I <sub>C</sub> =0			5	μA
h <sub>FE-1</sub>	DC current gain	I <sub>C</sub> =1A ; V <sub>CE</sub> =5V	55		160	
h <sub>FE-2</sub>	DC current gain	I <sub>C</sub> =4A ; V <sub>CE</sub> =5V	35			
f <sub>T</sub>	Transition frequency	I <sub>C</sub> =1A ; V <sub>CE</sub> =5V		30		MHz
C <sub>OB</sub>	Output capacitance	I <sub>E</sub> =0; V <sub>CB</sub> =10V; f=1MHz		120		pF

◆ h<sub>FE-1</sub> classifications

R	O
55-110	80-160

Silicon NPN Power Transistors

2SC5197

PACKAGE OUTLINE

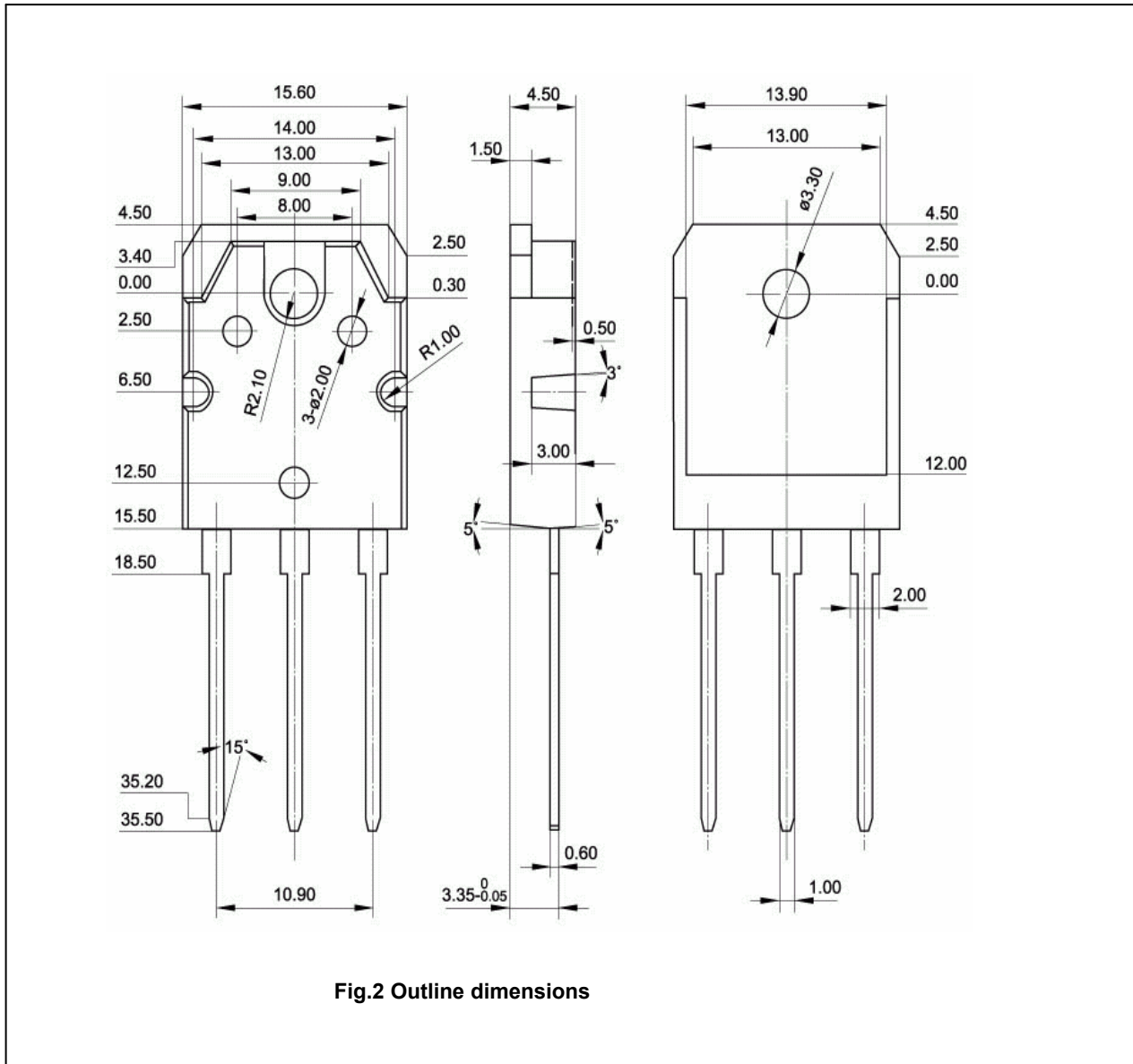

Fig.2 Outline dimensions

Silicon NPN Power Transistors

2SC5197

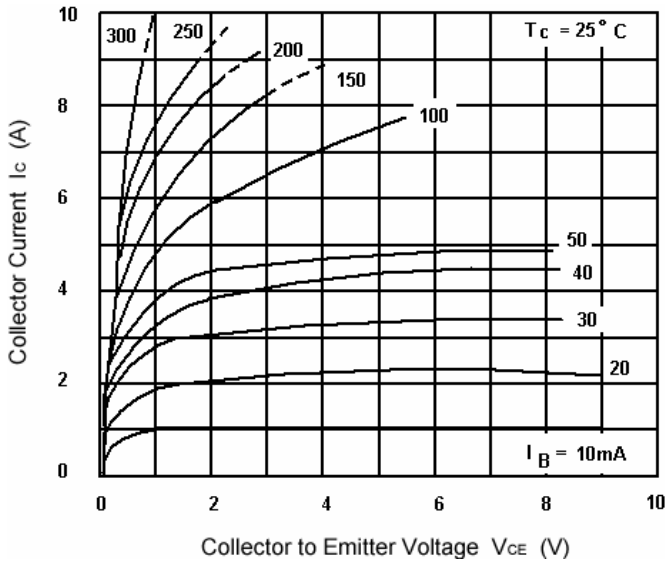

Fig.3 Static Characteristic

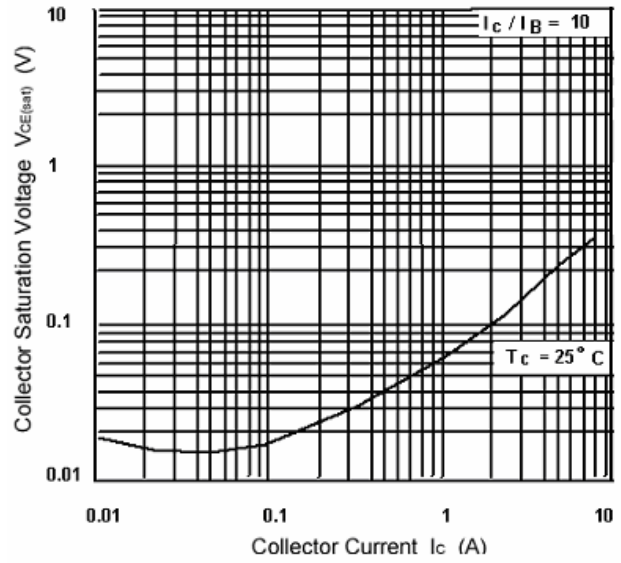

Fig.4 Collector-Emitter Saturation Voltage

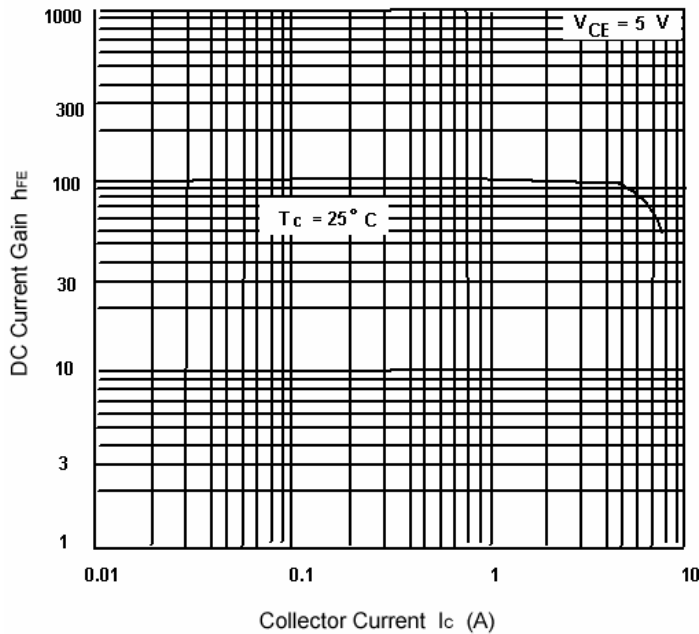

Fig.5 DC current Gain

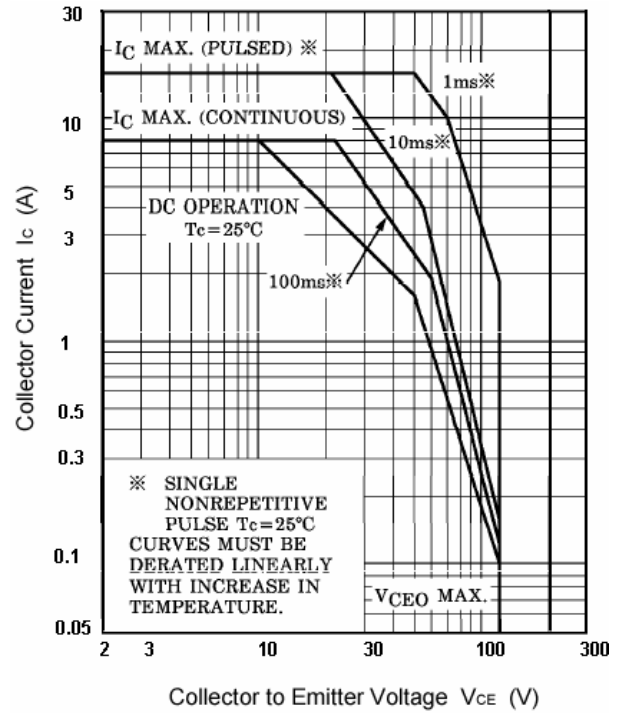

Fig.6 Safe Operating Area