

Package information - SOD523

Surface mounted, 2 pin package

Package outline

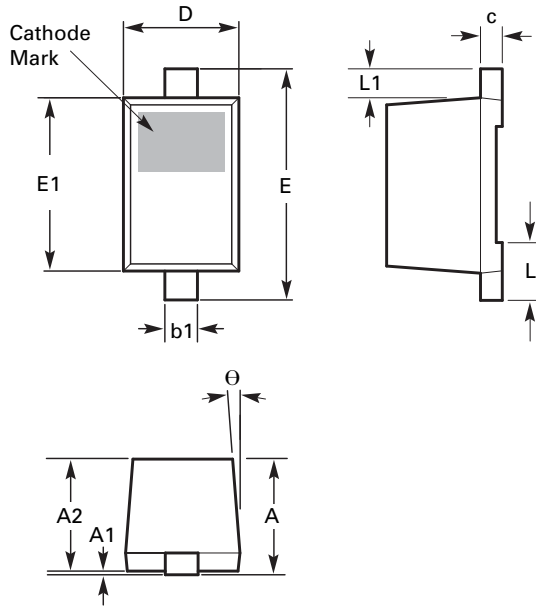

DIM	Millimeters		Inches		DIM	Millimeters		Inches	
	Min.	Max.	Min.	Max.		Min.	Max.	Min.	Max.
A	-	0.800	-	0.0314	E	1.500	1.700	0.0590	0.0669
A1	0.000	0.100	0.000	0.0039	E1	1.100	1.300	0.0433	0.0511
A2	0.600	0.800	0.0236	0.0314	L	0.200	0.400	0.0078	0.0157
b1	0.160	0.300	0.0062	0.0118	L1	0.170	0.230	0.0066	0.0090
c	0.080	0.220	0.0031	0.0086	θ	4°	10°	4°	10°
D	0.700	0.900	0.0275	0.0354	-	-	-	-	-

Note: Controlling dimensions are in millimeters. Approximate dimensions are provided in inches

Soldering footprint

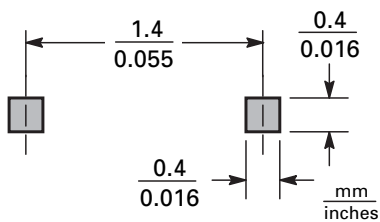

Package information - SOD523

Nominal weight

Nominal weight per device 1.37mg.

Tape and reel information

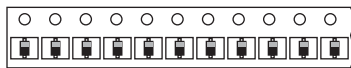
Orientation	Tape width (mm)	Reel size (inches)	No. of components	Tape option indicator
	8	7	3,000	TA
	8	13	10,000	TC

Embossed carrier tape configuration

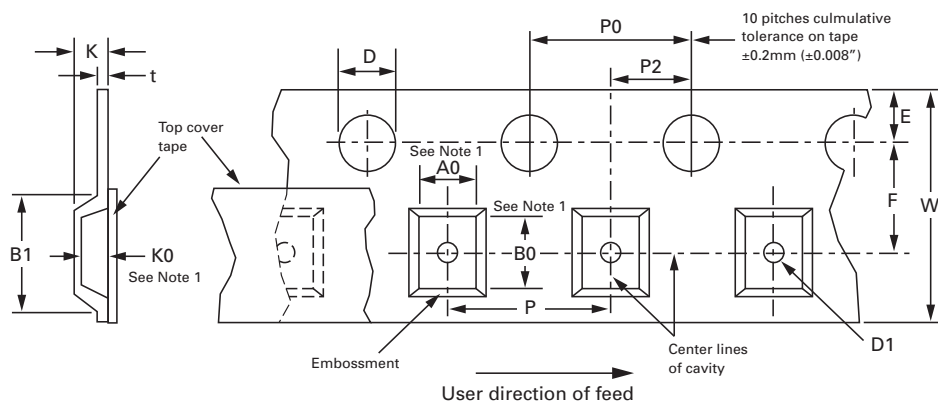

Dimensions mm (inches)	Tape size (mm)			
	8	12	16	24
A0, B0, K0	See note*	See note*	See note*	See note*
B1 (max.)	4.55 (0.179)	8.20 (0.323)	12.10 (0.476)	20.10 (0.791)
D	1.50 + 0.10 - 0.00	1.50 + 0.10 - 0.00	1.50 + 0.10 - 0.00	1.50 + 0.10 - 0.00
D1 (max.)	1.00 (0.039)	1.50 (0.059)	1.50 (0.059)	1.50 (0.059)
E	1.75 ± 0.10	1.75 ± 0.10	1.75 ± 0.10	1.75 ± 0.10
F	3.50 ± 0.10 (0.138 ± 0.004)	5.50 ± 0.05 (0.217 ± 0.002)	7.50 ± 0.10 (0.295 ± 0.004)	11.50 ± 0.10 (0.453 ± 0.004)
P	4.00 ± 0.10 (0.157 ± 0.004)	4.00 ± 0.10 (0.157 ± 0.004) 8.00 ± 0.10 (0.315 ± 0.004)	4.00 ± 0.10 (0.157 ± 0.004) 8.00 ± 0.10 (0.315 ± 0.004) 12.00 ± 0.10 (0.472 ± 0.004)	4.00 ± 0.10 (0.157 ± 0.004) to 20.00 ± 0.10 (0.787 ± 0.004) in 4.00 (0.157) increments
P0	4.00 ± 0.10	4.00 ± 0.10	4.00 ± 0.10	4.00 ± 0.10
P2	2.00 ± 0.05	2.00 ± 0.05	2.00 ± 0.05	2.00 ± 0.05
t (max.)	0.40	0.40	0.40	0.40
W	8.00 (0.315)	12.00 ± 0.30 (0.472 ± 0.012)	16.30 (0.642)	24.30 (0.957)

Package information - SOD523

NOTES:

* A0, B0 and K0 dimensions are determined with respect to EIA/JEDEC rotational and lateral movement requirements (see fig. 1).

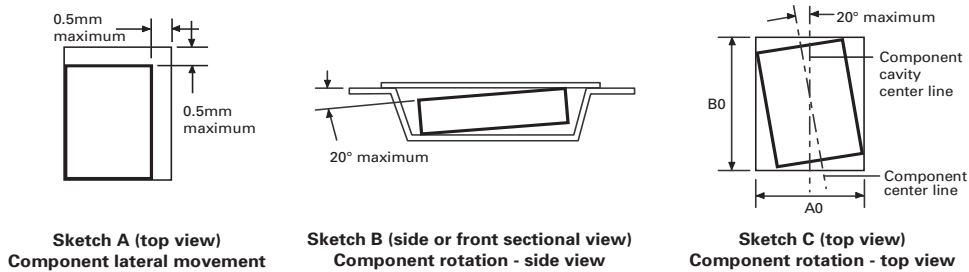
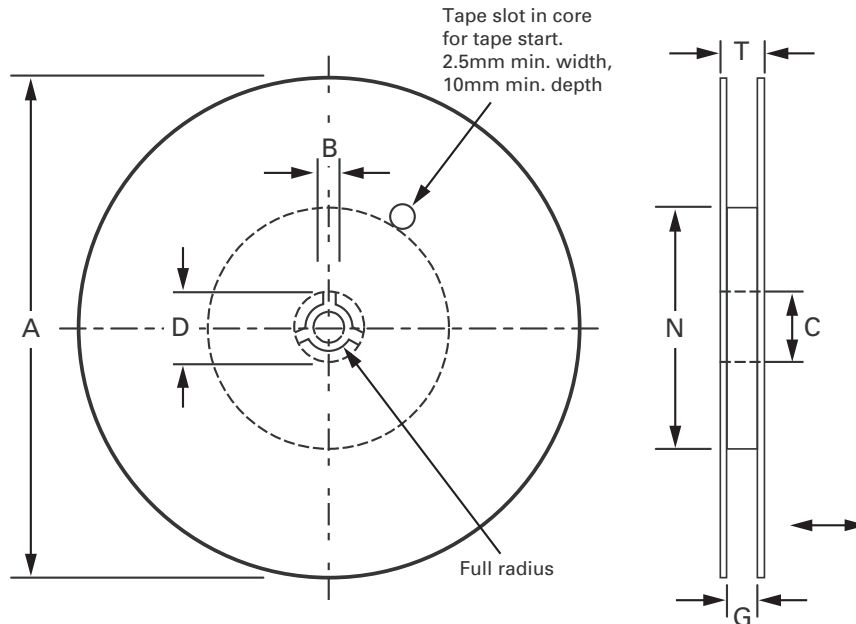

Figure 1 - rotational and lateral movement

Reel configuration



Tape option	A max.	B min.	C	D min.	N min.
TA	179 (7.047)	1.5 (0.06)	13.00 - 13.02 (0.512 - 0.52)	25.0 (0.984)	50 (1.969)
TC	330 (12.992)			20.2 (0.795)	

Tape size	G	T max.
8mm	8.4 -9.9 (0.33 - 0.39)	14.4 (0.567)
12mm	12.4 -16.4 (0.49 - 0.569)	18.4 (0.724)
16mm	16.4 -18.4 (0.65 - 0.729)	22.4 (0.882)
24mm	24.4 - 26.4 (0.96 - 1.039)	30.4 (1.197)

This publication is issued to provide outline information only which (unless agreed by the company in writing) may not be used, applied or reproduced for any purpose or form part of any order or contact or be regarded as a representation relating to the products or services concerned. The company reserves the right to alter without notice the specification, design, price or conditions of supply of any product or service.