

HD74AC194

4-bit Bidirectional Universal Shift Register

REJ03D0259-0200Z
(Previous ADE-205-379 (Z))
Rev.2.00
Jul.16.2004

Description

This bidirectional shift register is designed to incorporate virtually all of the features a system designer may want in a shift register. It features parallel inputs, parallel outputs, right shift and left shift serial inputs, operating mode control inputs, and a direct overriding clear line. The register has four distinct modes of operation: parallel (broadside) load, shift right (in the direction Q_0 toward Q_3); shift left; inhibit clock (do nothing).

Synchronous parallel loading is accomplished by applying the four bits of data and taking both mode control inputs, S_0 and S_1 , high. The data are loaded into their respective flip-flops and appear at the output after the positive transition of the clock input. During loading, serial data flow is inhibited. Shift right is accomplished synchronously with the rising edge of the clock pulse when S_0 is high and S_1 is low. Serial data for this mode is entered at the shift right data input. When S_0 is low and S_1 is high, data shifts left synchronously and new data is entered at the shifts left serial input. Clocking of the flip-flops is inhibited when both mode control inputs are low. The mode control inputs should be changed only when the clock input is high.

Features

- Asynchronous Master Reset
- Hole (Do Nothing) Mode
- Outputs Source/Sink 24 mA
- Ordering Information

Part Name	Package Type	Package Code	Package Abbreviation	Taping Abbreviation (Quantity)
HD74AC194FPEL	SOP-16 pin (JEITA)	FP-16DAV	FP	EL (2,000 pcs/reel)
HD74AC194RPEL	SOP-16 pin (JEDEC)	FP-16DNV	RP	EL (2,500 pcs/reel)

Notes: 1. Please consult the sales office for the above package availability.

2. The packages with lead-free pins are distinguished from the conventional products by adding V at the end of the package code.

Pin Arrangement

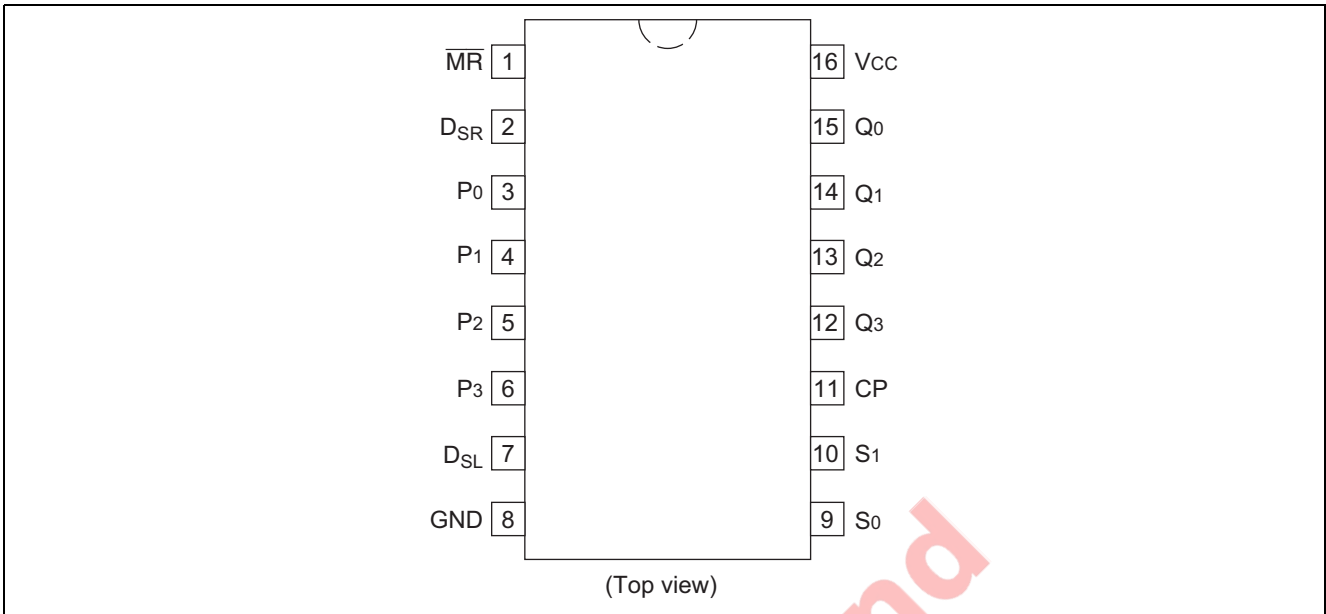

Logic Symbol

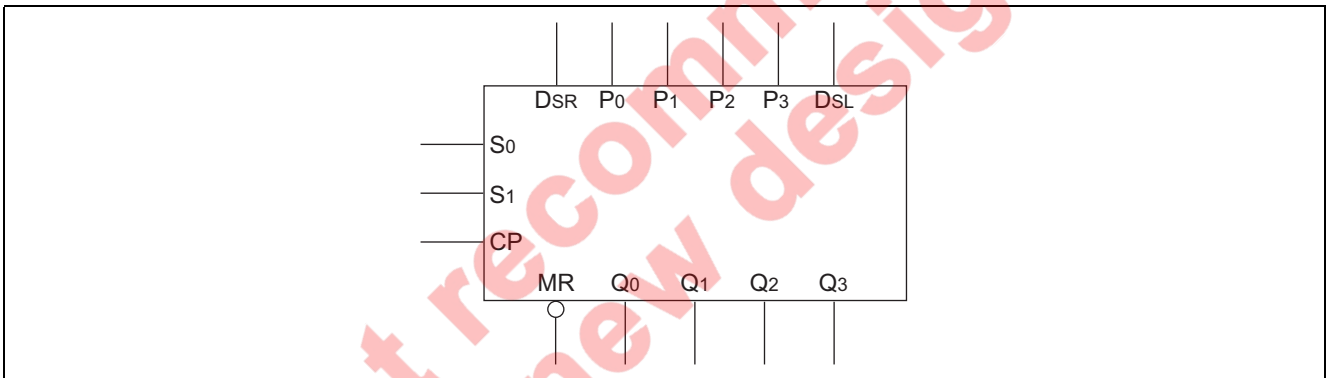

Pin Names

- S_0, S_1 Mode Control Inputs
- P_0 to P_3 Parallel Data Inputs
- D_{SR} Serial Data Input (Shift Right)
- D_{SL} Serial Data Input (Shift Left)
- CP Clock Pulse Input (Active Rising Edge)
- \overline{MR} Asynchronous Master Reset Input (Active LOW)
- Q_0 to Q_3 Parallel Outputs

Logic Diagram

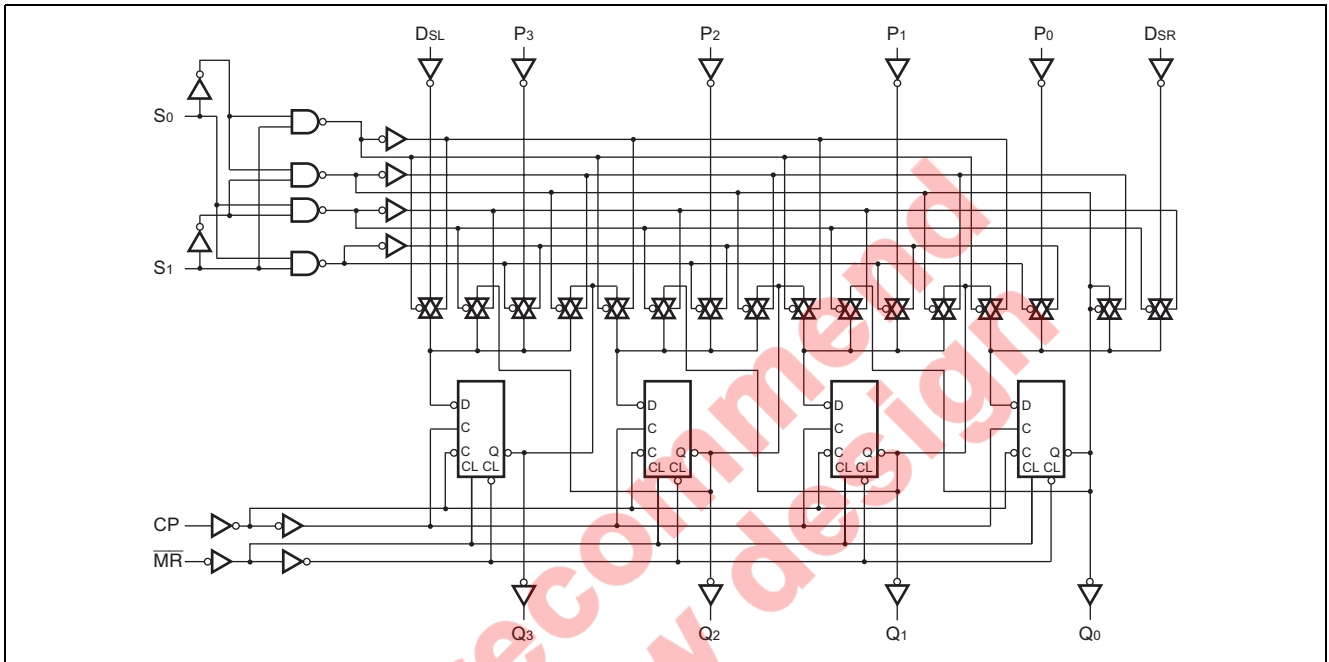

Mode Select Table

Operating Mode	Inputs						Output			
	\overline{MR}	S_1	S_0	D_{SR}	D_{SL}	P_n	Q_0	Q_1	Q_2	Q_3
Reset	L	X	X	X	X	X	L	L	L	L
Hold	H	L	L	X	X	X	q_0	q_1	q_2	q_3
Shift Left	H	H	L	X	L	X	q_1	q_2	q_3	L
	H	H	L	X	H	X	q_1	q_2	q_3	H
Shift Right	H	L	H	L	X	X	L	q_0	q_1	q_2
	H	L	H	H	X	X	H	q_0	q_1	q_2
Parallel Load	H	H	H	X	X	p_n	p_0	p_1	p_2	p_3

H : HIGH Voltage Level

L : LOW Voltage Level

p_n (q_n) : Lower case letters indicate the state of the referenced input (or output) one setup time prior to the LOW-to-HIGH clock transition

X : Immaterial

Timing Diagram

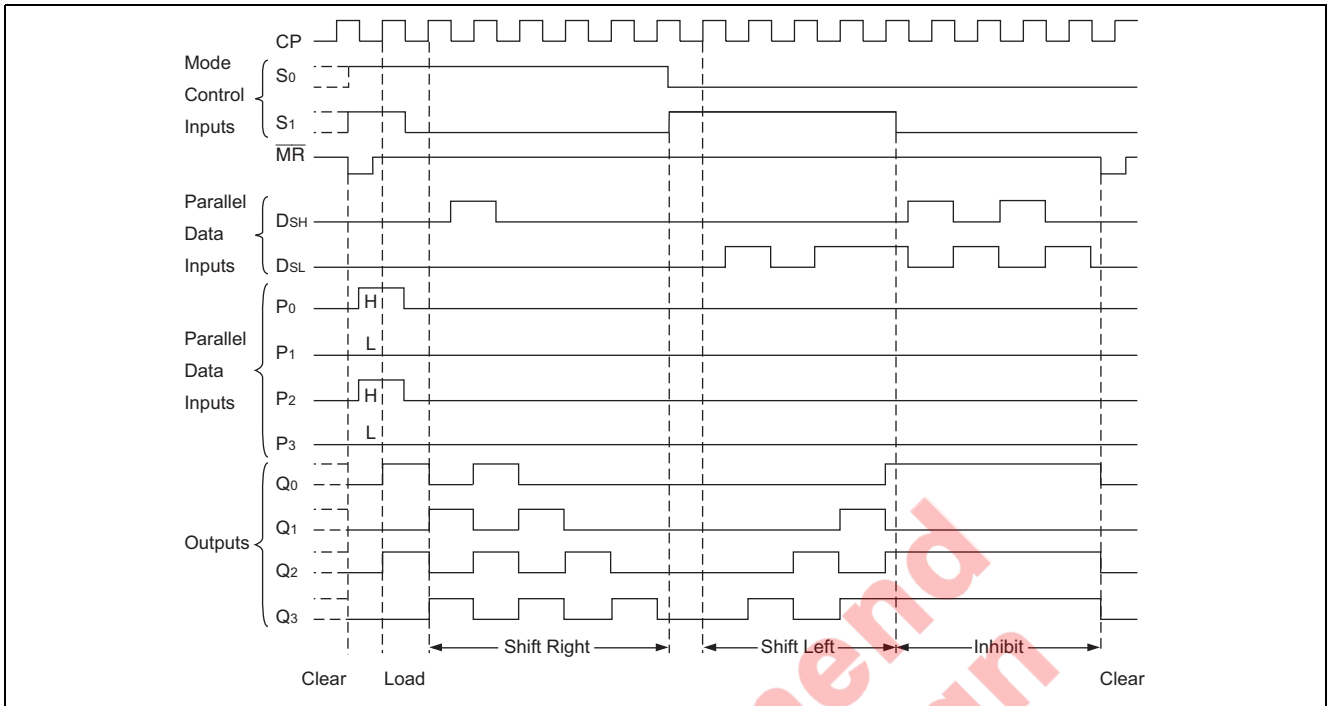

Absolute Maximum Ratings

Item	Symbol	Ratings	Unit	Condition
Supply voltage	V_{CC}	-0.5 to 7	V	
DC input diode current	I_{IK}	-20	mA	$V_I = -0.5V$
		20	mA	$V_I = V_{CC}+0.5V$
DC input voltage	V_I	-0.5 to $V_{CC}+0.5$	V	
DC output diode current	I_{OK}	-50	mA	$V_O = -0.5V$
		50	mA	$V_O = V_{CC}+0.5V$
DC output voltage	V_O	-0.5 to $V_{CC}+0.5$	V	
DC output source or sink current	I_O	± 50	mA	
DC V_{CC} or ground current per output pin	I_{CC}, I_{GND}	± 50	mA	
Storage temperature	T_{stg}	-65 to +150	$^{\circ}C$	

Recommended Operating Conditions

Item	Symbol	Ratings	Unit	Condition
Supply voltage	V_{CC}	2 to 6	V	
Input and output voltage	V_I, V_O	0 to V_{CC}	V	
Operating temperature	T_a	-40 to +85	$^{\circ}C$	
Input rise and fall time (except Schmitt inputs) V_{IN} 30% to 70% V_{CC}	tr, tf	8	ns/V	$V_{CC} = 3.0V$
				$V_{CC} = 4.5 V$
				$V_{CC} = 5.5 V$

DC Characteristics

Item	Symbol	V _{CC} (V)	Ta = 25°C			Ta = -40 to +85°C		Unit	Condition		
			min.	typ.	max.	min.	max.				
Input Voltage	V _{IH}	3.0	2.1	1.5	—	2.1	—	V	V _{OUT} = 0.1 V or V _{CC} -0.1 V		
		4.5	3.15	2.25	—	3.15	—				
		5.5	3.85	2.75	—	3.85	—				
	V _{IL}	3.0	—	1.50	0.9	—	0.9		V _{OUT} = 0.1 V or V _{CC} -0.1 V		
		4.5	—	2.25	1.35	—	1.35				
		5.5	—	2.75	1.65	—	1.65				
Output voltage	V _{OH}	3.0	2.9	2.99	—	2.9	—	V	V _{IN} = V _{IL} or V _{IH} I _{OUT} = -50 μA		
		4.5	4.4	4.49	—	4.4	—				
		5.5	5.4	5.49	—	5.4	—				
		3.0	2.58	—	—	2.48	—			V _{IN} = V _{IL} or V _{IH} I _{OH} = -12 mA	
		4.5	3.94	—	—	3.80	—				I _{OH} = -24 mA
		5.5	4.94	—	—	4.80	—				I _{OH} = -24 mA
	V _{OL}	3.0	—	0.002	0.1	—	0.1	V	V _{IN} = V _{IL} or V _{IH} I _{OUT} = 50 μA		
		4.5	—	0.001	0.1	—	0.1				
		5.5	—	0.001	0.1	—	0.1				
		3.0	—	—	0.32	—	0.37			V _{IN} = V _{IL} or V _{IH} I _{OL} = 12 mA	
		4.5	—	—	0.32	—	0.37				I _{OL} = 24 mA
		5.5	—	—	0.32	—	0.37				I _{OL} = 24 mA
	Input leakage current	I _{IN}	5.5	—	—	±0.1	—	±1.0	μA	V _{IN} = V _{CC} or GND	
	Dynamic output current*	I _{OLD}	5.5	—	—	—	86	—	mA	V _{OLD} = 1.1 V	
		I _{OHD}	5.5	—	—	—	-75	—	mA	V _{OHD} = 3.85 V	
Quiescent supply current	I _{CC}	5.5	—	—	8.0	—	80	μA	V _{IN} = V _{CC} or ground		

*Maximum test duration 2.0 ms, one output loaded at a time.

AC Characteristics

Item	Symbol	V _{CC} (V)*1	Ta = +25°C C _L = 50 pF			Ta = -40°C to +85°C C _L = 50 pF		Unit
			Min	Typ	Max	Min	Max	
Maximum clock frequency	f _{max}	3.3	75	—	—	65	—	MHz
		5.0	100	—	—	85	—	
Propagation delay CP to Q _n	t _{PLH}	3.3	1.0	—	13.0	1.0	15.0	ns
		5.0	1.0	—	10.0	1.0	11.5	
Propagation delay CP to Q _n	t _{PHL}	3.3	1.0	—	13.0	1.0	15.0	ns
		5.0	1.0	—	10.0	1.0	11.5	
Propagation delay MR to Q _n	t _{PHL}	3.3	1.0	—	10.5	1.0	12.5	ns
		5.0	1.0	—	8.0	1.0	9.0	

Note: 1. Voltage Range 3.3 is 3.3 V ± 0.3 V
Voltage Range 5.0 is 5.0 V ± 0.5 V

AC Operating Requirements

Item	Symbol	V _{CC} (V)*1	Ta = +25°C C _L = 50 pF		Ta = -40°C to +85°C C _L = 50 pF	Unit
			Typ	Guaranteed Minimum		
Setup time, HIGH or LOW P _n or D _{SR} or D _{SL} to CP	t _{su}	3.3	—	5.5	7.0	ns
		5.0	—	4.0	5.0	
Hold time, HIGH or LOW P _n or D _{SR} or D _{SL} to CP	t _h	3.3	—	2.0	3.0	ns
		5.0	—	1.5	2.0	
Setup time, HIGH or LOW S _n to CP	t _{su}	3.3	—	6.0	7.5	ns
		5.0	—	4.5	5.5	
Hold time, HIGH or LOW S _n to CP	t _h	3.3	—	0.0	0.0	ns
		5.0	—	0.0	0.0	
Recovery time MR̄ to CP	t _{rec}	3.3	—	0.5	0.5	ns
		5.0	—	0.5	0.5	
Pulse width	t _w	3.3	—	5.5	7.0	ns
		5.0	—	4.5	5.0	

Note: 1. Voltage Range 3.3 is 3.3 V ± 0.3 V
Voltage Range 5.0 is 5.0 V ± 0.5 V

Capacitance

Item	Symbol	Typ	Unit	Condition
Input capacitance	C _{IN}	4.5	pF	V _{CC} = 5.5 V
Power dissipation capacitance	C _{PD}	100	pF	V _{CC} = 5.0 V

Package Dimensions

As of January, 2003
Unit: mm

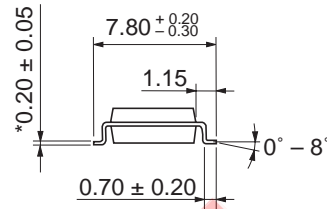
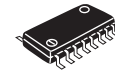
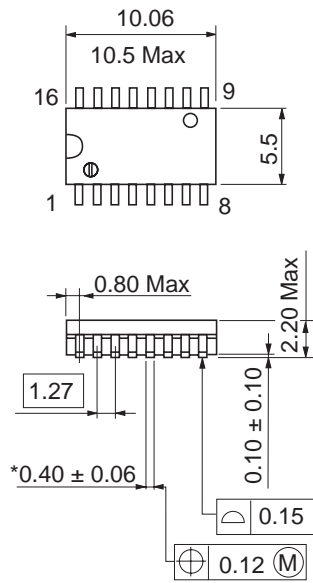

*Ni/Pd/Au plating

Package Code	FP-16DAV
JEDEC	—
JEITA	Conforms
Mass (reference value)	0.24 g

As of January, 2003
Unit: mm

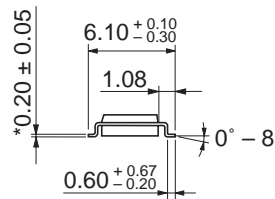
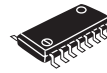
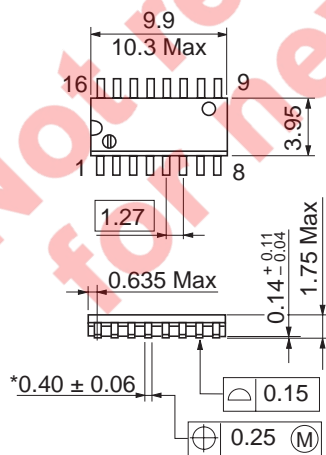

*Ni/Pd/Au plating

Package Code	FP-16DNV
JEDEC	Conforms
JEITA	Conforms
Mass (reference value)	0.15 g

Renesas Technology Corp. Sales Strategic Planning Div. Nippon Bldg., 2-6-2, Ohte-machi, Chiyoda-ku, Tokyo 100-0004, Japan

Keep safety first in your circuit designs!

1. Renesas Technology Corp. puts the maximum effort into making semiconductor products better and more reliable, but there is always the possibility that trouble may occur with them. Trouble with semiconductors may lead to personal injury, fire or property damage. Remember to give due consideration to safety when making your circuit designs, with appropriate measures such as (i) placement of substitutive, auxiliary circuits, (ii) use of nonflammable material or (iii) prevention against any malfunction or mishap.

Notes regarding these materials

1. These materials are intended as a reference to assist our customers in the selection of the Renesas Technology Corp. product best suited to the customer's application; they do not convey any license under any intellectual property rights, or any other rights, belonging to Renesas Technology Corp. or a third party.
 2. Renesas Technology Corp. assumes no responsibility for any damage, or infringement of any third-party's rights, originating in the use of any product data, diagrams, charts, programs, algorithms, or circuit application examples contained in these materials.
 3. All information contained in these materials, including product data, diagrams, charts, programs and algorithms represents information on products at the time of publication of these materials, and are subject to change by Renesas Technology Corp. without notice due to product improvements or other reasons. It is therefore recommended that customers contact Renesas Technology Corp. or an authorized Renesas Technology Corp. product distributor for the latest product information before purchasing a product listed herein.
The information described here may contain technical inaccuracies or typographical errors.
Renesas Technology Corp. assumes no responsibility for any damage, liability, or other loss rising from these inaccuracies or errors.
Please also pay attention to information published by Renesas Technology Corp. by various means, including the Renesas Technology Corp. Semiconductor home page (<http://www.renesas.com>).
 4. When using any or all of the information contained in these materials, including product data, diagrams, charts, programs, and algorithms, please be sure to evaluate all information as a total system before making a final decision on the applicability of the information and products. Renesas Technology Corp. assumes no responsibility for any damage, liability or other loss resulting from the information contained herein.
 5. Renesas Technology Corp. semiconductors are not designed or manufactured for use in a device or system that is used under circumstances in which human life is potentially at stake. Please contact Renesas Technology Corp. or an authorized Renesas Technology Corp. product distributor when considering the use of a product contained herein for any specific purposes, such as apparatus or systems for transportation, vehicular, medical, aerospace, nuclear, or undersea repeater use.
 6. The prior written approval of Renesas Technology Corp. is necessary to reprint or reproduce in whole or in part these materials.
 7. If these products or technologies are subject to the Japanese export control restrictions, they must be exported under a license from the Japanese government and cannot be imported into a country other than the approved destination.
Any diversion or reexport contrary to the export control laws and regulations of Japan and/or the country of destination is prohibited.
 8. Please contact Renesas Technology Corp. for further details on these materials or the products contained therein.
-



RENESAS SALES OFFICES

<http://www.renesas.com>

Renesas Technology America, Inc.

450 Holger Way, San Jose, CA 95134-1368, U.S.A
Tel: <1> (408) 382-7500 Fax: <1> (408) 382-7501

Renesas Technology Europe Limited.

Dukes Meadow, Millboard Road, Bourne End, Buckinghamshire, SL8 5FH, United Kingdom
Tel: <44> (1628) 585 100, Fax: <44> (1628) 585 900

Renesas Technology Europe GmbH

Dornacher Str. 3, D-85622 Feldkirchen, Germany
Tel: <49> (89) 380 70 0, Fax: <49> (89) 929 30 11

Renesas Technology Hong Kong Ltd.

7/F., North Tower, World Finance Centre, Harbour City, Canton Road, Hong Kong
Tel: <852> 2265-6688, Fax: <852> 2375-6836

Renesas Technology Taiwan Co., Ltd.

FL 10, #99, Fu-Hsing N. Rd., Taipei, Taiwan
Tel: <886> (2) 2715-2888, Fax: <886> (2) 2713-2999

Renesas Technology (Shanghai) Co., Ltd.

26/F., Ruijin Building, No.205 Maoming Road (S), Shanghai 200020, China
Tel: <86> (21) 6472-1001, Fax: <86> (21) 6415-2952

Renesas Technology Singapore Pte. Ltd.

1, Harbour Front Avenue, #06-10, Keppel Bay Tower, Singapore 098632
Tel: <65> 6213-0200, Fax: <65> 6278-8001