



SW11B Series Sine Wave Oscillators

December 2006



- Pletronics' SW11B Series is a quartz crystal controlled precision sine wave signal source.
- FR4 base with a mechanical metal cover.
- Low Profile (2.9mm maximum)
- Tape and Reel or Tube packaging is available.
- 10 to 700 MHz
- 14.0mm x 9.9mm package
- 5V Operation
- Excellent phase noise performance
- 50 ohm load with internal blocking capacitor

Pletronics Inc. certifies this device is in accordance with the RoHS 6/6 (2002/95/EC) and WEEE (2002/96/EC) directives.

Pletronics Inc. guarantees the device does not contain the following:
Cadmium, Hexavalent Chromium, Lead, Mercury, PBB's, PBDE's
Weight of the Device: 1.33 grams
Moisture Sensitivity Level: 1 As defined in J-STD-020C
Second Level Interconnect code: e4

Absolute Maximum Ratings:

Parameter	Unit
V _{CC} Supply Voltage	-0.5V to +7.0V
V _i Input Voltage	-0.5V to V _{CC} + 0.5V
V _o Output Voltage	-0.5V to V _{CC} + 0.5V

Thermal Characteristics

The maximum die or junction temperature is 155°C
The thermal resistance junction to board is 60 to 100°C/Watt depending on the solder pads, ground plane and construction of the PCB.

PART NUMBER:

SW11	45	BY	E	- 230.0M	- XX	
						Internal code or blank
						Frequency in MHz
						Optional Enhanced OTR E = Temperature range -40 to 85°C
						Series Model
						Frequency Stability 45 = ± 50 ppm 44 = ± 25 ppm 20 = ± 20 ppm
						Series Model

Part Marking:

PLE SW11 or SWYWWXX
 FF.FFFM FF.FFFM
 • YMDXX • PXXXXX

Legend:

P or PLE = Pletronics
 FF.FFFM = Frequency in MHz
 YWW or YMD = Date of Manufacture
 (year and week, or year,
 month and day)

All other marking is internal factory codes

Specifications such as frequency stability, supply voltage and operating temperature range, etc. are not identified from the marking. External packaging labels and packing list will correctly identify the ordered Pletronics part number.

Codes for Date Code YMD

Code	6	7	8	9	0	1	2
Year	2006	2007	2008	2009	2010	2011	2012

Code	A	B	C	D	E	F	G	H	J	K	L	M
Month	JAN	FEB	MAR	APR	MAY	JUN	JUL	AUG	SEP	OCT	NOV	DEC

Code	1	2	3	4	5	6	7	8	9	A	B	C
Day	1	2	3	4	5	6	7	8	9	10	11	12
Code	D	E	F	G	H	J	K	L	M	N	P	R
Day	13	14	15	16	17	18	19	20	21	22	23	24
Code	T	U	V	W	X	Y	Z					
Day	25	26	27	28	29	30	31					

Electrical Specification:

for Supply Voltage V_{CC} of 5.0V $\pm 5\%$, over the specified temperature range

Item	Min	Max	Unit	Condition	
Frequency Range	10	700	MHz		
Frequency Accuracy	--	--	ppm	Determined by part number and inclusive for power supply, temperature and load	
Harmonic Output	--	-15	dBc		
Spurious Output	--	-50	dBc	of V_{CC} (See load circuit)	
Output Level	-7.0	-4.0	dBm	Load of 50 ohms	
Aging	Year 1	-5.0	+5.0	ppm	at 25°C
	Subsequent	-2.0	+2.0	ppm	
Phase Noise	10 Hz offset	--	-59	dBc/Hz	Example at 200MHz
	100 Hz	--	-87		
	1 KHz	--	-118		
	10 KHz	--	-147		
	100 KHz	--	-150		
	1 MHz	--	-152		
	10 MHz	--	-152		
Current I_{CC}	-	90	mA	Pin 1 low, device disabled	
Start up time	-	10	mS	Time for output to reach specified frequency	
Operating Temperature Range	0	+70	°C	Standard Temperature Range	
	-40	+85	°C	Extended Temperature Range "E" Option	
Storage Temperature Range	-55	+125	°C		

Load Circuit (50 ohm nominal load and no capacitance)

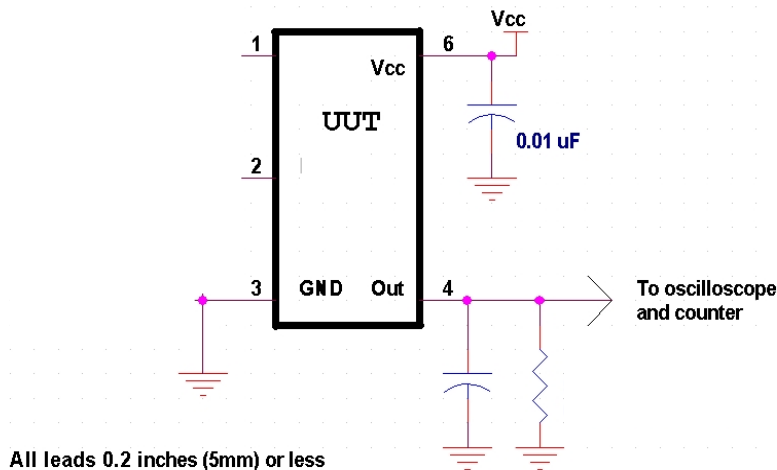

Mechanical

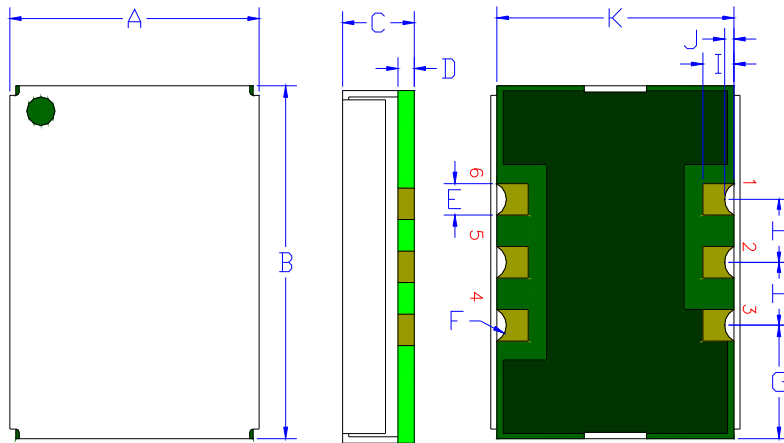

FR4 PCB Base:
 Solder masked
 All via holes tented on bottom
 Copper Clad ½ oz. Typical
 Gold plated 0.02 µinch (0.5 µm)
Label:
 White Kapton with Black Letters
 –or–
 Blue Epoxy heat cure covering
 top with laser marked lettering

Cover:
 Centered on the base
 304 Stainless Steel
 0.010 inch (0.25µm)
 Electroless Nickel Plated
 1 µinch (25 µm) typical
 Pin 2 Ground plane is typical
 Not to scale

	Inches	mm
A	0.390 ±0.010	9.90 ±0.25
B	0.550 ±0.010	13.97 ±0.25
C	0.115 max	2.92 max
D ¹	0.026 typ.	0.66
E ¹	0.050	1.27
F ¹	0.028 R	0.72 R
G ¹	0.180	4.57
H ¹	0.200	5.08
I ¹	0.050	1.27
J ¹	0.015	0.38
K ¹	0.380	9.65

Pad	Function	Note
1	NC	no connection
2	NC	no connection
3	Ground (GND)	
4	Output	50 ohm load, internal DC blocking capacitor rated at 25V
5	NC	no connection
6	Supply Voltage (V _{CC})	Recommend connecting appropriate power supply bypass capacitors as close as possible.

Reflow Cycle (typical for lead free processing)

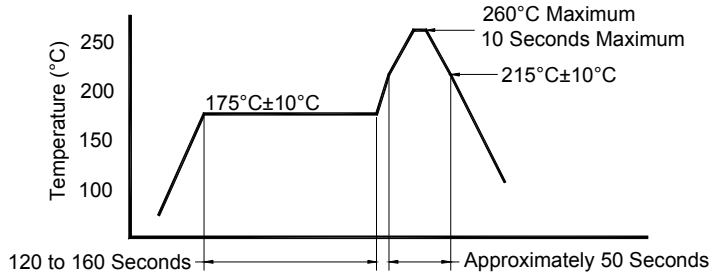

The part may be reflowed 2 times without degradation.

Allowed rate of temperature change
Maximum 4°C per second

Tape and Reel: available for quantities of 250 to 1000 per reel

Constant Dimensions Table 1								
Tape Size	D0	D1 Min	E1	P0	P2	S1 Min	T Max	T1 Max
8mm	1.5	1.0	1.75	4.0	2.0 +0.05	0.6	0.6	0.1
12mm		1.5			2.0 ±0.1			
16mm		+0.1 -0.0			±0.1			
24mm		1.5			±0.1			

Variable Dimensions Table 2							
Tape Size	B1 Max	E2 Min	F	P1	T2 Max	W Max	Ao, Bo & Ko
24 mm	15.54	22.25	11.5 ± 0.1	16.0 ± 0.1	5.16	24.3	Note 1

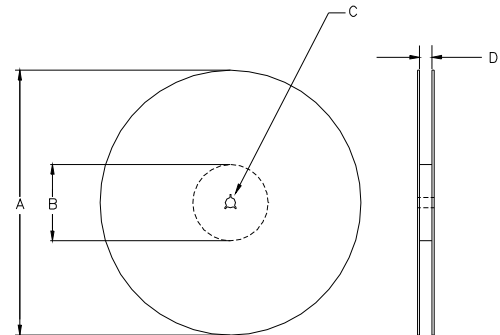

Note 1: Embossed cavity to conform to EIA-481-B Dimensions in mm Not to scale

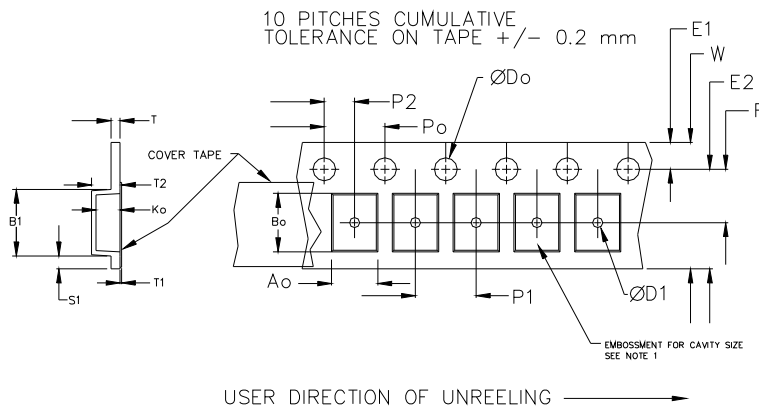

REEL DIMENSIONS					
A	inches	7.0	10.0	13.0	Tape Width
	mm	177.8	254.0	330.2	
B	inches	2.50	4.00	3.75	Tape Width
	mm	63.5	101.6	95.3	
C	mm	13.0 +0.5 / -0.2			Tape Width
D	mm	16.4 +2.0 -0.0	16.4 +2.0 -0.0	16.4 +2.0 -0.0	
		mm	---	---	24.4 +2.0 -0.0
	mm	---	---	32.4 +2.0 -0.0	32.0

Reel dimensions may vary from the above

Tape and Reel labeling

Label is 1" x 2.6" (25.4mm x 66.7mm)
 Font is Courier New
 Bar code is 39-Full ASCII
 (Part number will read
 SW11xxBY-106.25M for example)

Label is 1" x 2.6" (25.4mm x 66.7mm)
 Font is Arial

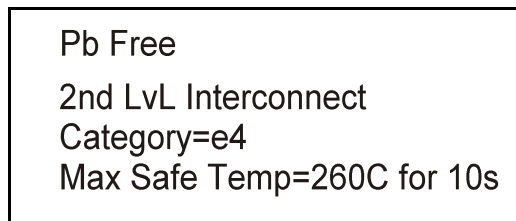

Layout and application information

For Optimum Jitter Performance, Pletronics recommends:

- a ground plane under the device
- no large transient signals (both current and voltage) should be routed under the device
- do not layout near a large magnetic field such as a high frequency switching power supply
- do not place near piezoelectric buzzers or mechanical fans.

Reliability: Environmental Compliance

Parameter	Condition
Mechanical Shock	MIL-STD-883 Method 2002, Condition B
Vibration	MIL-STD-883 Method 2007, Condition A
Solderability	MIL-STD-883 Method 2003
Thermal Shock	MIL-STD-883 Method 1011, Condition A

ESD Rating

Model	Minimum Voltage	Conditions
Human Body Model	1500	MIL-STD-883 Method 3115
Charged Device Model	1000	JESD 22-C101

IMPORTANT NOTICE

Pletronics Incorporated (PLE) reserves the right to make corrections, improvements, modifications and other changes to this product at anytime. PLE reserves the right to discontinue any product or service without notice. Customers are responsible for obtaining the latest relevant information before placing orders and should verify that such information is current and complete. All products are sold subject to PLE's terms and conditions of sale supplied at the time of order acknowledgment.

PLE warrants performance of this product to the specifications applicable at the time of sale in accordance with PLE's limited warranty. Testing and other quality control techniques are used to the extent PLE deems necessary to support this warranty. Except where mandated by specific contractual documents, testing of all parameters of each product is not necessarily performed.

PLE assumes no liability for application assistance or customer product design. Customers are responsible for their products and applications using PLE components. To minimize the risks associated with the customer products and applications, customers should provide adequate design and operating safeguards.

PLE products are not designed, intended, authorized or warranted to be suitable for use in life support applications, devices or systems or other critical applications that may involve potential risks of death, personal injury or severe property or environmental damage. Inclusion of PLE products in such applications is understood to be fully at the risk of the customer. Use of PLE products in such applications requires the written approval of an appropriate PLE officer. Questions concerning potential risk applications should be directed to PLE.

PLE does not warrant or represent that any license, either express or implied, is granted under any PLE patent right, copyright, artwork or other intellectual property right relating to any combination, machine or process which PLE product or services are used. Information published by PLE regarding third-party products or services does not constitute a license from PLE to use such products or services or a warranty or endorsement thereof. Use of such information may require a license from a third party under the patents or other intellectual property of the third party, or a license from PLE under the patents or other intellectual property of PLE.

Reproduction of information in PLE data sheets or web site is permissible only if the reproduction is without alteration and is accompanied by associated warranties, conditions, limitations and notices. Reproduction of this information with alteration is an unfair and deceptive business practice. PLE is not responsible or liable for such altered documents.

Resale of PLE products or services with statements different from or beyond the parameters stated by PLE for that product or service voids all express and implied warranties for the associated PLE product or service and is an unfair or deceptive business practice. PLE is not responsible for any such statements.

Contacting Pletronics Inc.

Pletronics Inc.
19013 36th Ave. West
Lynnwood, WA 98036-5761 USA

Tel: 425-776-1880
Fax: 425-776-2760
E-mail: ple-sales@pletronics.com
URL: www.pletronics.com

Copyright © 2005, 2006, Pletronics Inc.