

FILAMENT REPLACEMENT LEDs - Multi-LED Cluster

FEATURES



**216 SERIES**

PACK QUANTITY = 1 PIECE

- Direct replacement for BA22
- 20 LED Cluster
- Reverse polarity options availability
- Optional polycarbonate lens
- Bi-polar

SPECIFICATIONS

Ordering Information & Typical Technical Characteristics (Ta = 25°C)

Mean Time Between Failure = 100,000 Hours. Luminous intensity figures refer to the unmodified discrete LED.

PART NUMBER	COLOUR	LENS	VOLTAGE AC/DC Vopr	CURRENT DC Iopr	LUMINOUS INTENSITY Iv@20mA	WAVE LENGTH λp	OPERATING TEMP Topr	STORAGE TEMP Tstg		
<b>HIGH INTENSITY</b>										
216-501-22-65	Red		Water Clear	24	20	11000	643	-40 ~ +95^	-40 ~ +100	Yes
216-521-22-65	Yellow		Water Clear	24	20	16000	591	-40 ~ +95^	-40 ~ +100	Yes
216-532-22-65	Green		Water Clear	24	20	23000	527	-40 ~ +95^	-40 ~ +100	Yes
216-930-22-65	Blue		Water Clear	24	20	7000	470	-40 ~ +95^	-40 ~ +100	Yes
216-997-22-65	Cool White		Water Clear	24	20	14000	see below	-40 ~ +95^	-40 ~ +100	Yes
216-501-25-65	Red		Water Clear	110	20	11000	643	-40 ~ +95^	-40 ~ +100	Yes
216-521-25-65	Yellow		Water Clear	110	20	16000	591	-40 ~ +95^	-40 ~ +100	Yes
216-532-25-65	Green		Water Clear	110	20	23000	527	-40 ~ +95^	-40 ~ +100	Yes
216-930-25-65	Blue		Water Clear	110	20	7000	470	-40 ~ +95^	-40 ~ +100	Yes
216-997-25-65	Cool White		Water Clear	110	20	14000	see below	-40 ~ +95^	-40 ~ +100	Yes
<b>UNITS</b>			<b>Vac/dc</b>	<b>mA</b>	<b>mcd</b>	<b>nm</b>	<b>°C</b>	<b>°C</b>		



<b>997</b>	*Typical emission colour cool white			
x	0.296	0.283	0.330	0.330
y	0.276	0.305	0.360	0.318

Please note that this product is also available in different voltages. Contact our sales department for further details.

^ = Products must be derated according to the derating information. Each derating graph refers to specific LEDs. Appropriate LED numbers shown. - Refer to page 2.

Intensities (Iv) and colour shades of white (x,y co-ordinates) may vary between LEDs within a batch.

How to Order:

website: [www.marl.co.uk](http://www.marl.co.uk) • email: [sales@marl.co.uk](mailto:sales@marl.co.uk) • webstore: [www.leds.co.uk](http://www.leds.co.uk)

• Telephone +44 (0)1229 582430 • Fax: +44 (0)1229 585155

The information contained in this datasheet does not constitute part of any order or contract and should not be regarded as a representation relating to either products or service. Marl International reserve the right to alter without notice the specification or any conditions of supply for products or service.

## 216 Series

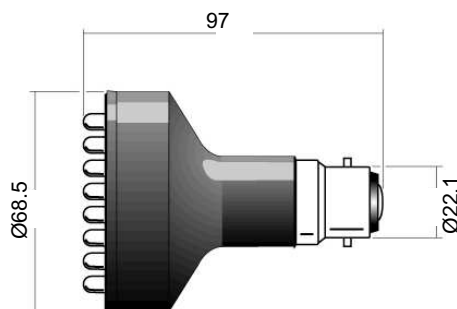

Dimensions in mm (Typical)  
Scale 2 : 1

### TECHNICAL INFORMATION

Lamp Base Style	Series	Metric Equivalent (mm)	Maximum Power Dissipation (mW)
BA22 Filament Base	216	26	2500

### DESIGN CONSIDERATIONS

#### Single-Chip LEDs

All devices feature water clear high intensity LEDs as standard. The single chip LED devices have been modified by the removal of the domed portion of the encapsulation (flat-topped) to provide even illumination of switches and annunciators. Non flat topped versions are also available, please contact the sales department for details.

#### Product Evaluation

Filament Replacement LEDs have been specifically designed to meet the primary objective of providing improved reliability. As this product range is suitable for both new-build and retro-fit, (sometimes in very old systems), a wide range of illuminated push button switches and lamp holders can be encountered. Due to subjectivity, evaluation of the LED type is recommended, (samples of all standard models are available). Care should be taken to correctly simulate operating ambient light conditions to ensure that the correct device has been selected to maximise viewing characteristics such as viewing angle, colour compatibility and on/off contrast ratio.

#### Power derating

The forward voltage/current value of an LED is dependant upon the ambient temperature of the environment in which it is operated. Therefore, care must be taken to operate the LED at the correct voltage/current values, depending upon the ambient temperature. Consequently, a recommendation regarding operating voltages and currents is given in order to address these temperature effects. This recommendation is termed 'de-rating'.

It is usual for forward voltages and currents to be specified for ambient temperature of 25°C. However, because the values of these qualities vary with temperature, Marl should be contacted if the device is to be operated at a temperature significantly higher than 25°C.

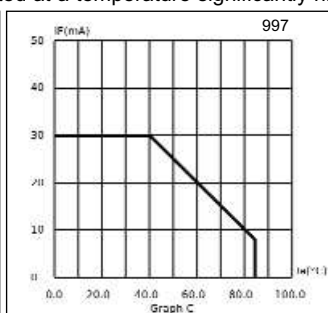
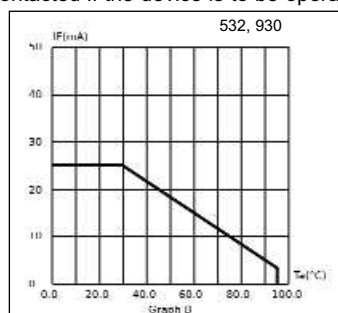
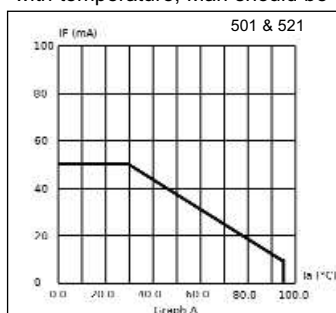

Marl accept no liability for any product that is operated higher than the stated voltage.

#### Electro-static Discharge (ESD)

Build up of electrostatic discharge occurs in many situations involving people moving and handling products. The range of possible situations is very diverse but voltage levels as high as several thousand volts can and do arise in many individual situations. When an operator charged up to these levels handles a 'static sensitive device', there is a very probable likelihood that the device will be irreversibly damaged. It is essential that precautions are taken at all stages during manufacture and assembly of these products. Although LEDs were never considered to be static sensitive devices, changes in manufacturing technology and materials used to produce higher intensity products over a large range of the wavelength spectrum have changed this. Marl has an approved system of ESD control from goods in, through production and into final packing and despatch. We recommend all users of LED based products follow the guidelines of BS 100015.

Note: All luminous intensity figures refer to the unmodified discrete LED.

#### How to Order:

website: [www.marl.co.uk](http://www.marl.co.uk) • email: [sales@marl.co.uk](mailto:sales@marl.co.uk) • webstore: [www.leds.co.uk](http://www.leds.co.uk)

• Telephone +44 (0)1229 582430 • Fax: +44 (0)1229 585155

The information contained in this datasheet does not constitute part of any order or contract and should not be regarded as a representation relating to either products or service. Marl International reserve the right to alter without notice the specification or any conditions of supply for products or service.



BS EN ISO 9001:2000  
Approved Manufacturer